

 LEAPMOTOR



# B10

## USER MANUAL

Foreword	
<b>Foreword</b>	<b>6</b>
User Notice	
<b>Notice to users</b>	<b>8</b>
<b>Statement</b>	<b>8</b>
Event data recorder (EDR)	8
Vehicle Testing	8
Hardware and software modifications	9
Product Change	9
Vehicle scrapping	9
Product recall	9
<b>New car features</b>	<b>10</b>
Exterior vehicle	10
Inside the car	11
Vehicle charging/discharging	
<b>Charging precautions</b>	<b>12</b>
<b>Charging port</b>	<b>13</b>
<b>AC Charging Connectors</b>	<b>13</b>
AC charger (British TYPE G power plug)*	13
AC charger (GB TYPE I power plug)*	13
AC charger (Thailand, Philippines TYPE B power plug)*	14
AC charger (South African TYPE M power plug)*	14
AC charger (M3 dual-head plug)*	14
<b>Charging methods</b>	<b>14</b>
Inspection before charging	14
How to charge	14
Emergency unlocking of AC slow charging/DC fast charging	15
<b>Scheduled charging*</b>	<b>16</b>
<b>Vehicle-to-Load Power Discharge</b>	<b>16</b>
Discharge Explanation	16
Inspection before discharging	16

Discharge Operation Instructions	16
Safety device	
<b>Seatbelt</b>	<b>18</b>
The protective role of the seat belt	18
Correctly wear the seat belt	18
Pregnant women should correctly wear the seat belt	20
Seat belt unfastened warning	20
Seat belt inspection and maintenance	20
<b>Airbag</b>	<b>21</b>
The protective role of airbags	21
Airbag location	22
Airbag malfunction indicator lamp	23
Cases in which the airbag may deploy	23
Cases in which the airbag may not deploy	24
Replacement of airbag system components	25
<b>Car Restraints for Children</b>	<b>25</b>
Instructions for children on board	25
Disable front passenger airbag*	26
Child Seat Selection Recommendations	27
Installing the ISOFIX child restraint system	27
Information on the applicability of child restraint systems	29
Instrument and Control Systems	
<b>Instrument cluster</b>	<b>30</b>
Instrument Cluster Display Information	30
Instrument cluster indicator	31
<b>Infotainment screen</b>	<b>36</b>
Main Interface Display Information	36
Quick Actions	36
Vehicle Settings	37
Application center	41
Speech recognition	41
OTA update	42
Map Update*	42
<b>Car key</b>	<b>46</b>

NFC key.....	46
Mechanical key.....	47
Bluetooth key.....	47

**Door..... 47**

Door unlocking/locking with NFC key.....	47
Bluetooth key unlocking/locking door.....	48
Steering wheel button to unlock/lock door.....	48
Infotainment screen button to unlock/lock door..	48
Door unlocking/locking with mechanical key.....	48
Open the door outside the vehicle.....	49
Inside door opening handle.....	49
Child safety lock.....	50
Door not closed reminder.....	50
Collision auto unlocking.....	50
Auto locking when driving.....	50

**Electric liftgate\*..... 50**

Open/Close the liftgate.....	50
Emergency opening of power liftgate.....	51
Anti-pinch function of liftgate.....	52

**Liftgate\*..... 52**

Open/Close the liftgate.....	52
Emergency unlocking of manual liftgate.....	52

**Electric window..... 53**

Driver side window control.....	53
Controlling vehicle windows via the infotainment screen.....	53
Car window anti-pinch function.....	54
Initialize window.....	54

**Electric sunshade..... 54**

Sunshade control.....	54
Sunshade anti-pinch function.....	54
Sunshade initialization.....	54

**Bonnet..... 55**

Hood opening.....	55
Hood closed.....	55

**Exterior Mirrors..... 56**

Exterior rearview mirror power adjustment.....	56
Outside rear-view mirror heating.....	56
Electric folding of the exterior rearview mirror.....	56
Exterior rearview mirrors auto-fold when locking*.....	56
Manual folding of the exterior rearview mirror.....	57

**Inside rear-view mirror..... 57**

Interior rearview mirror adjustment.....	57
Manual anti-glare.....	57

**Steering wheel..... 57**

Steering wheel button information.....	57
Horn.....	58
Adjust the steering wheel.....	58
Steering Wheel Heating*.....	59

**Seats..... 59**

Front driver seat.....	59
Front row front passenger seat.....	60
Front headrest height adjustment.....	61
Front seat heating/ventilation*.....	61
Rear seat adjustment.....	62
Rear seat headrest height adjustment.....	63

**Windshield wiper and washer..... 64**

Controlling the front wiper.....	64
Washing the front windshield.....	64

**Exterior lighting..... 65**

Controlling vehicle lamps via the Infotainment Screen.....	65
Controlling vehicle lamps through the control lever.....	66
High-mounted stop lamp and stop lamp.....	67
rear reversing lamp.....	67

**Interior lighting..... 67**

Front reading light.....	67
Vanity mirror light.....	67
Ambient light*.....	67
Trunk Illuminating Light.....	67

---

**A/C control system..... 69**

Front vent.....	69
Rear Seat Vent.....	70
A/C control panel.....	71

**Leapmotor App..... 74**

Leapmotor App Download.....	74
User Registration and Login.....	74
Binding/Unbinding Vehicle.....	74
Remote Control.....	74

**Vehicle Equipment****Storage devices.....77**

Trunk.....	77
Front storage box and cup holder.....	77
Rear seat storage box and cup holder.....	78
Door storage box.....	79
Front Engine Compartment Storage Box*.....	79
Storage bag on the front seat backrest.....	80

**Electronic device..... 80**

Mobile phone wireless charger.....	80
12V power supply interface.....	81
USB port.....	81

**Other Devices..... 82**

Sun visor.....	82
Vanity mirror.....	82
Safety handle.....	82
Clothes hook.....	83
Cargo shield.....	83

**Starting and driving****Driving Instructions..... 84**

Pre-driving inspection.....	84
Driving Safety Precautions.....	84
New vehicle break-in period.....	85

**Correct Sitting Posture.....85**

Driver's correct sitting posture.....	85
---------------------------------------	----

Correct sitting posture of front passenger occupant.....	85
Correct seating posture for rear passengers.....	86

**Start driving..... 86**

Gear.....	86
Pedal.....	87
Electronic Parking Brake (EPB).....	87
Start the vehicle.....	89
Start the vehicle using the password.....	89
Acceleration mode.....	89
Getting started.....	89
Parking.....	90
Energy recovery.....	90
Alcolock Interface.....	91

**Driving and Environment..... 91**

Economical Driving.....	91
Driving with a load.....	92
Driving on slopes.....	92
High-Speed Driving.....	92
Night Driving.....	93
Driving in Fog.....	93
Driving in rainy and snowy weather.....	93
Winter driving precautions.....	94
Tire Anti-Skid Chain.....	95
Hot weather driving.....	95
Precautions for driving over waterlogged roads..	96
Precautions for different road conditions.....	96
Low-temperature driving.....	97

**Safety warning system..... 97**

Anti-theft alarm system.....	97
Acoustic vehicle alerting systems (AVAS).....	97
Tire pressure monitoring system (TPMS).....	98
Lane Departure Warning (LDW).....	98
Lane Keeping Assist (LKA).....	100
Forward Collision Warning (FCW).....	102
Rear Collision Warning (RCW).....	104
Blind Spot Warning (BSW).....	105
Rear Cross Traffic Alert (RCTA).....	106
Rear Cross Traffic Braking (RCTB).....	107

Door Opening Warning (DOW).....	108
In-vehicle Life Monitoring System*.....	109

**Advanced driver assistance systems (ADAS)..... 110**

Radar and Camera.....	110
Full-Speed Adaptive Cruise Control (ACC).....	112
Lane Centering Control (LCC).....	116
Emergency Lane Keeping Assist (ELK).....	118
Intelligent Speed Assistance (ISA)*.....	118
Driver Drowsiness and Attention Warning System (DDAW).....	119
Advanced Driver Distraction Warning (ADDW) System.....	120

**Vehicle electronic brake system..... 121**

Electronic Stability Control (ESC).....	121
Anti-lock Brake System (ABS).....	122
Electronic brakeforce distribution system (EBD).....	123
Traction Control System (TCS).....	123
Hydraulic brake assist (HBA).....	124
Hill hold control (HHC).....	124
Hill Descent Control (HDC).....	124
Anti-Rolling System (ARP).....	125
Post-collision Mitigation Brake System.....	125
Emergency Stop Signal (ESS).....	125
Autohold.....	125
Automatic Emergency Braking (AEB).....	126

**Electronic Power Steering (EPS).... 127**

**Parking Assist System..... 128**

Around View Monitor.....	128
--------------------------	-----

**Dashcam..... 129**

Vehicle inspection and maintenance

**In-cab inspection..... 131**

Check driver's seat.....	131
Check seat belt.....	131
Check all types of mirrors.....	131
Check remaining battery level.....	131

**Vehicle Oil and Tire Inspection..... 131**

Check Windshield Washing Fluid.....	131
Check coolant.....	131
Check brake fluid.....	132
Check tire pressure and tread.....	132

**A/C air filter element check..... 133**

**Check after starting the vehicle.... 133**

Check the operation of the instrument cluster....	133
Check the horn.....	133
Check the lights.....	133
Check the wiper and washer.....	133
Check the steering wheel.....	133

**Vehicle trial operation inspection.. 133**

Check brake system.....	133
Check the steering system.....	133

**Vehicle maintenance..... 134**

Maintenance Instructions.....	134
Preventing Corrosion.....	134
Notes on routine maintenance items.....	134
Body cleaning.....	135
Vehicle Waxing.....	136
Paint Maintenance.....	136
Cleaning and maintenance of external plastic parts .....	136
Clean glass.....	137
Cleaning the interior.....	137
Sealing strip maintenance.....	139
Tire.....	139
Brake Wear.....	140

**Battery..... 140**

Battery Assembly Precautions.....	140
Battery maintenance.....	140

**Power battery..... 141**

Power battery characteristics.....	141
Power battery usage recommendations.....	142
Power Battery Recycling.....	144

**Fuse..... 144**

Fuse Instructions.....	144
Check fuse.....	144
Replace the fuse.....	144
Fuse Box in Front Compartment.....	144
Instrument panel fuse box.....	145
Fuse box in the rear compartment.....	145
Battery Positive Terminal Fuse Box.....	145
Front Compartment Fuse Position Distribution...	146
Instrument Panel Fuse Position Distribution.....	149
Rear Compartment Fuse Position Distribution...	151
Battery Positive Terminal Fuse Position Distribution .....	153

**Wiper blade..... 154**

Turn on the wiper maintenance function.....	154
Replace Wiper Blade.....	154

**Bulb..... 154**

Light Bulb Inspection.....	154
Light bulb replacement.....	154
Vehicle lamp fogging.....	154

Warranty and Maintenance

**Regular Maintenance..... 156**

Importance of Maintenance.....	156
Maintenance Location.....	156
Maintenance Content.....	157
Maintenance Interval Table.....	160

Emergency response

**Emergency response device..... 165**

Hazard warning lamp.....	165
e-Call Emergency Assistance*.....	165
Attached tools.....	165
Warning triangle.....	166
Reflective vest.....	166
Car Emergency Hammer.....	167

**Accident Handling..... 167**

Tire Blowout.....	167
Tire flat.....	167
Vehicle trapped.....	168
Tire inflation.....	168
Tire repair operation.....	168
Vehicle Towing.....	168
External Trailer*.....	170
Jump starting.....	175

**Emergency Response Plan..... 175**

Emergency response to fire.....	175
Water crossing emergency response.....	176
Charging emergency response.....	177
Emergency treatment for power battery leakage.....	177

Technical Information

**Vehicle identification..... 179**

Vehicle Identification Number (VIN).....	179
Vehicle Nameplate and Identification.....	179
Microwave window.....	181

**Technical parameters..... 183**

Vehicle Basic Parameters.....	183
Power Battery Technical Parameters.....	186
Motor Technical Parameters.....	187
Brake system technical parameters.....	187
Wheel and Tire Technical Parameters.....	188
Seat technical parameters.....	188
Other main assembly technical parameters.....	190
Type and dosage of vehicle filling fluid.....	190
Light Bulb Parameters.....	191
Radio Technology Information.....	192
SVHC Information Transmission.....	194

## FOREWORD

### Dear Leapmotor Owner:

Thank you for choosing the safe, comfortable, powerful, and economical Leapmotor vehicle! As a technology company, we always put users first, co-create and share with users, and are committed to becoming a high-quality, international, and respected global smart electric vehicle company with core technological capabilities. We look forward to creating maximum value for your vehicle and life with high-quality products and services.

Before using the vehicle, please read the contents of this manual carefully and keep it properly for future reference. This manual will help you better understand and use Leapmotor vehicles, so that your vehicle can keep its best performance in future use. In-depth knowledge of the vehicle will help you have a clearer understanding of the safety and fun of the vehicle.

If you have any problems or needs in the process of use, please contact the authorized dealer nearby. We will provide you with the best service in maintenance and repair. Please be sure to complete the maintenance work on time in accordance with the maintenance provisions of the OEM.

This manual aims to provide a comprehensive overview of the vehicle information that is essential for your understanding. Due to different model configurations and subsequent OTA upgrades, the instructions in this manual may be different from the actual configurations of the vehicle you purchased, and the actual vehicle you received shall prevail. Additionally, certain vehicle functions require specific network conditions; in different network environments, these functions may not operate properly. Thank you for your understanding. Leapmotor reserves the right to change, supplement or terminate the contents of this manual without further notice.

This manual is an integral part of the vehicle. When selling or lending this vehicle, please hand over this manual to the new owner.

Thank you for your support and appreciation of Leapmotor. We wish you a pleasant experience with your vehicle!

November 2025

No content of this manual may be reprinted or reproduced without the written permission of Leapmotor.

Violators will be prosecuted.

With regard to the safety precautions for the use of vehicle, we explain them through the warning labels on the vehicle and the safety tips in this manual.

- Warning sign: For specific locations, see the "Vehicle Nameplate and Markings" section.
- Safety tips: Explained through the symbols and texts in this manual.

### WARNING

- Failure to do could result in casualties or serious damage to the vehicle.

### ATTENTION

- Failure to do could result in personal injury or damage to your vehicle.

### NOTE

- Tips for better use and maintenance of your vehicle.

### ECO

- The content is related to environmental protection.
  
- The function/configuration marked with the symbol "\*" in this manual indicates that it is only applicable to some models.
- The illustrations used in this manual are mainly used to show some characteristics or functions of the vehicle, and are for reference only. Please refer to the actual vehicle for specific details.
- Except for special instructions, the instructions on the vehicle orientation (front, rear, left, and right) in this manual are based on the forward direction of the vehicle.

## NOTICE TO USERS

1. Before you use the vehicle, be sure to read this manual carefully and strictly follow the operating methods described in this manual during vehicle use. Leapmotor will not be responsible for any damage caused by your improper use of the vehicle.
2. Be sure to perform regular vehicle maintenance and servicing as specified in the Maintenance Contents and Maintenance Interval Schedule sections.
3. Drivers and occupants should wear seat belts correctly and maintain the correct posture to ensure driving safety and comfort.
4. Before driving, please check whether the following items meet the safety requirements for driving and riding:
  - Seat position.
  - Brake pedal.
  - Wiper.
  - Driving mileage.
  - Inside and exterior rearview mirror angles.
  - Steering wheel position.
  - Tire.
  - All vehicle lamps.
5. Before the driver leaves the vehicle, make sure the gear is shifted to Park (P), and confirm that the parking brake indicator light is on.
6. While the vehicle is moving, if the fault warning light in the instrument cluster is illuminated or there is a fault text indication, the driver should stop safely as soon as possible to check and contact an authorized dealer.
7. The driving mileage displayed in the vehicle's instrument cluster may deviate from the actual mileage, so please refer to the actual mileage.
8. Please strictly comply with road traffic regulations and drive the vehicle safely.
9. If there is a recall for this model at a later date, we will notify you separately.

## STATEMENT

### EVENT DATA RECORDER (EDR)

This vehicle is equipped with an event data recorder (EDR) system. Depending on the type and severity of the crash, the event data recorder (EDR) may record the following content (including, but not limited to, the following data information from the vehicle's dynamic stability control (DSC) system and safety systems during the crash):

- Brake pedal/accelerator pedal position.

- Vehicle travel speed (vehicle speed is wheel speed, derived from wheel speed sensor).
- Vehicle longitudinal acceleration.
- Seat belt lock status.

The above data can be used to restore the status of the vehicle at the time of the incident and aid in analysis.

Due to the limited space available for saving event data recorder (EDR) data, the system categorizes saved events into overwriteable events and non-overwriteable events:

- An overwriteable event is an incident-like scenario where data from such an event may be overwritten when storage space is low. For example, data saved when a collision event occurs but does not reach the airbag trigger threshold.
- Non-overwriteable events will be continuously stored in the event data recorder (EDR). For example, the data saved when an airbag deploys or a seat belt pretensioner deployment occurs.

We do not disclose data to third parties except in the following situations:

- Agreement with the vehicle owner (or lessee of the vehicle for hire).
- At the official request of the police, court, or government agency.
- It is used only for Leapmotor's technical diagnosis, research, and development of the vehicle, and does not disclose information about the owner or his or her identity.

Access to event data recorder (EDR) data:

- Special technical equipment is required to read the data from the event data recorder (EDR). To read the data from the event data recorder (EDR) or for more information, it is recommended that you contact an authorized dealer.

## VEHICLE TESTING

To ensure the quality of delivery of new Leapmotor vehicles, quality control technicians conduct comprehensive road tests on the vehicles before they leave the factory. As a result, a small number of kilometers will appear on your vehicle's odometer.

## HARDWARE AND SOFTWARE MODIFICATIONS

Equipment or boutique accessories that have not been modified, retrofitted, dismantled, or repaired by authorized dealers may damage the vehicle and threaten personal safety. Illegal modification of the vehicle is prohibited.

- Do not modify the chassis system of the vehicle, as it may affect the vehicle's handling safety and threaten personal safety.
- Please do not modify the electronic parts of the vehicle (wiring, lamps, and control units, etc.), and it is strictly prohibited to privately flash and Root, which may lead to system fault and threaten personal safety.
- Do not modify the seat, steering wheel, seat belt, and airbag system, as it may affect safety and threaten personal safety.
- Do not modify the relevant charging equipment to avoid charging fault and fire.

It is recommended to use genuine Leapmotor original parts or approved parts. Leapmotor carries out rigorous testing of parts to ensure their comfort, safety and reliability.

For modifications and additions to the vehicle, it is recommended to contact an authorized dealer.

## PRODUCT CHANGE

Leapmotor reserves the right to make design changes to the vehicle and is under no obligation to make the same or similar changes to vehicles already sold.

## VEHICLE SCRAPPING

The vehicle's airbag device contains explosive chemicals. If the vehicle is scrapped while the airbag is still in place, it may cause a fire or other incident. Before scrapping, it is recommended that the device be scrapped by an authorized dealer or other qualified repair shop.

## PRODUCT RECALL

When conducting a product recall, Leapmotor will provide reasonable solutions based on the product defects. If the problem can be solved by repair or replacement of parts, in order to eliminate vehicle defects as soon as possible and ensure your

driving safety, you should actively cooperate with the Leapmotor Service Center or authorized dealer to carry out recall repair services after receiving the recall notice from Leapmotor or obtaining relevant information through official channels.

## NEW CAR FEATURES

### EXTERIOR VEHICLE

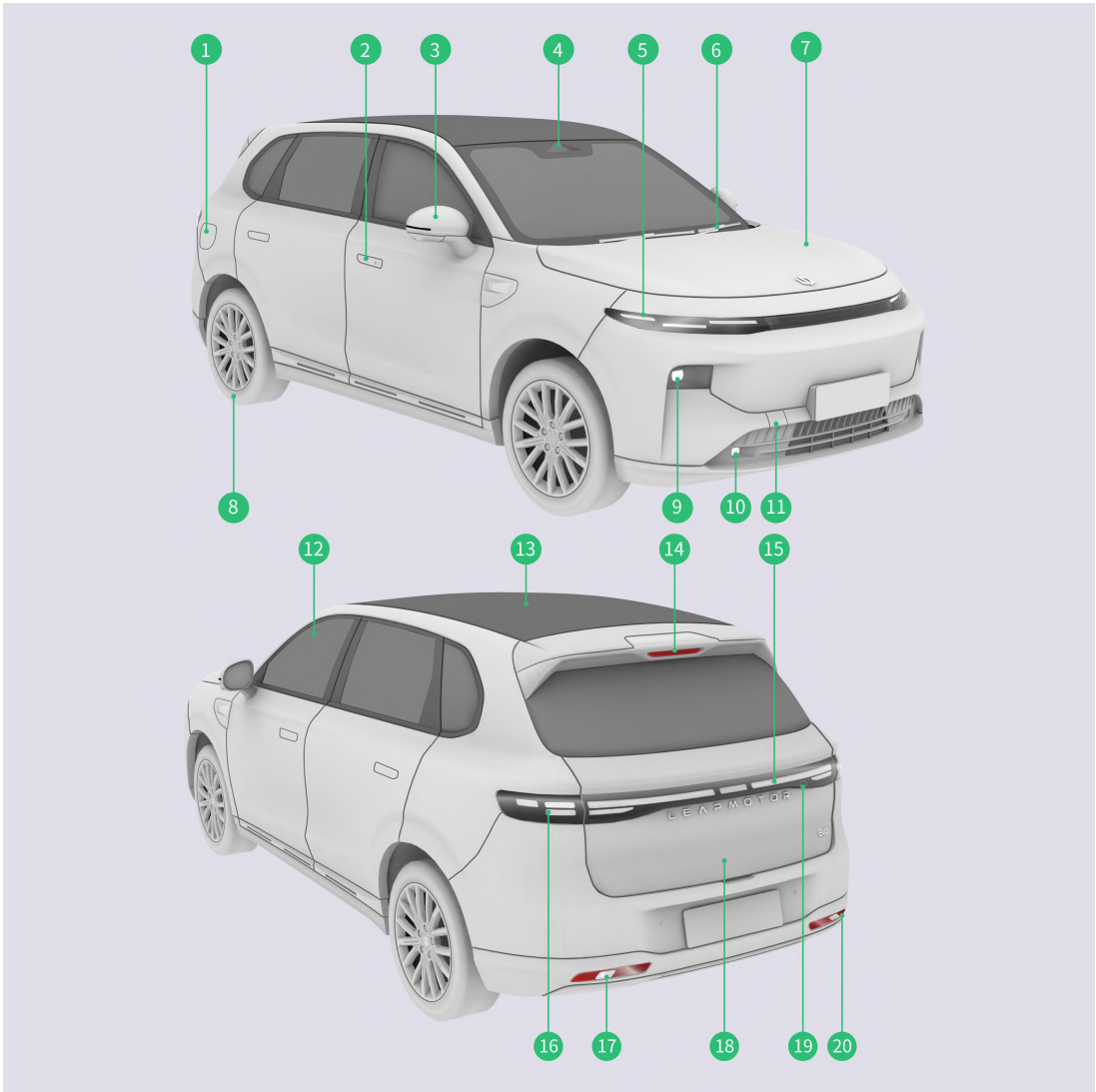

1. Charge port plate

4. Front-view camera

7. Front hood

10. Front fog lamp

13. Panoramic sunroof

16. Rear combination lamp

19. Liftgate external switch

2. Door handle

5. Direction indicator lamp

8. Wheel

11. Front towing eye

14. High-mounted stop lamp

17. Reversing lamp

20. Rear fog lamp

3. Exterior rearview mirror

6. Wiper

9. High/Low beam

12. Window

15. Through-type tail lamp

18. Liftgate

## INSIDE THE CAR

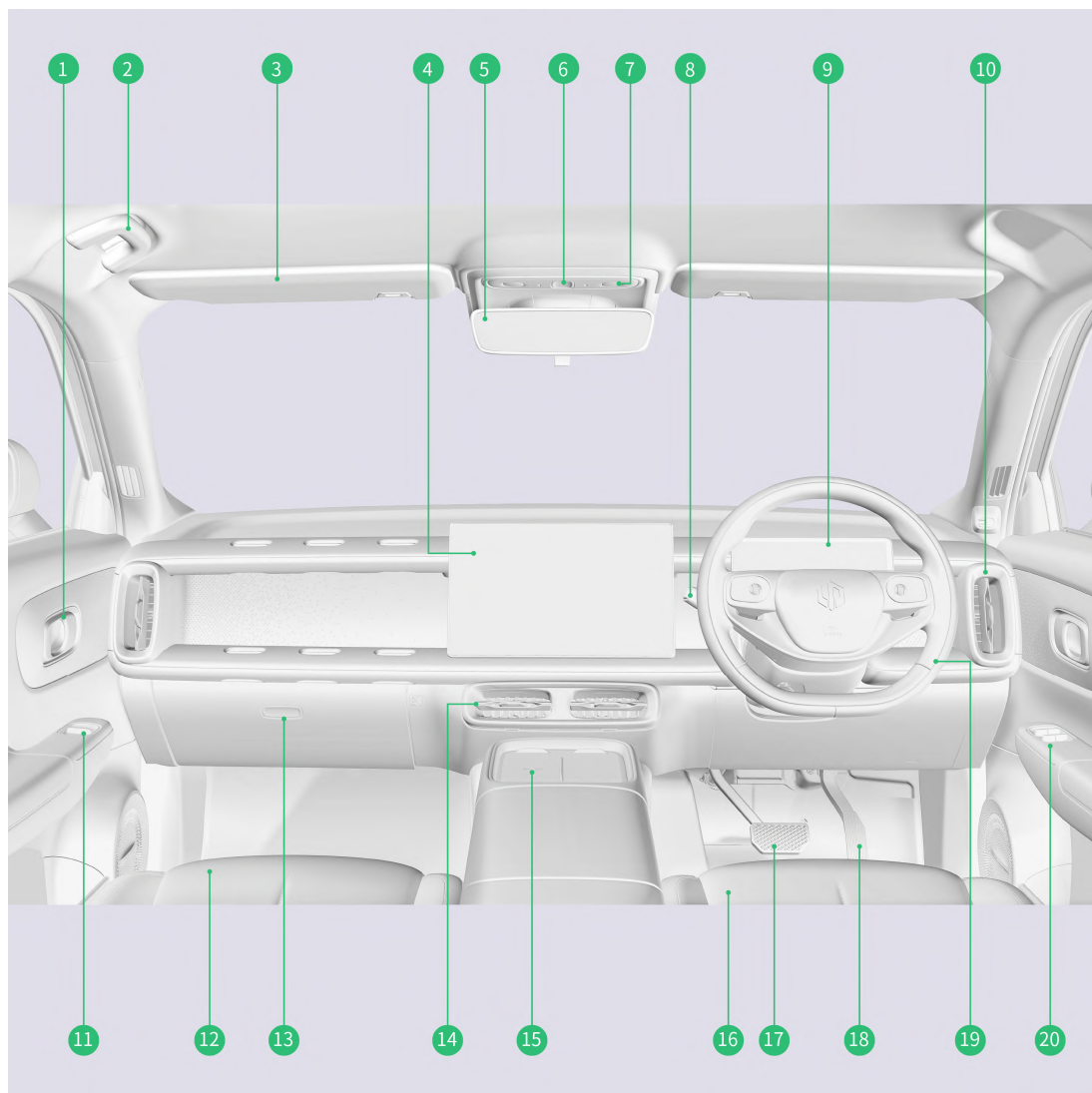

1. Inside door opening handle

4. Infotainment Screen

7. Reading light

10. Driver seat vent

13. Glove box

16. Driver's seat

19. Steering wheel

2. Safety handle

5. Interior rearview mirror

8. Wiper control lever

14. Front central vent

17. Brake pedal

20. Driver electric window button

3. Sun visor

6. Hazard warning lamp switch

9. Instrument cluster

11. Front passenger electric window button

15. Mobile phone wireless charging area

18. Accelerator pedal

11

12

13

14

15

16

17

18

19

20

## CHARGING PRECAUTIONS

Charging precautions:

- When the power battery low battery warning lamp in the instrument cluster illuminates for the first time or the battery level is  $\leq 10\%$ , please recharge the vehicle within 72 hours.
- Before charging, please make sure the vehicle is in Park (P) and the parking brake system is engaged.
- When the ambient temperature is below  $0^{\circ}\text{C}$ , the charging power is low and the charging speed is slow at the beginning stage of charging. As the battery temperature rises, the charging power will increase and the charging speed will become faster.
- When the ambient temperature is higher than  $45^{\circ}\text{C}$ , the charging power is low and the charging speed is slow at the beginning stage of charging. As the battery temperature decreases, the charging power will increase and the charging speed will become faster.
- When charging with quick charging piles, quick charging piles with a voltage range covering the vehicle charging voltage range should be selected, and it is recommended to prioritize quick charging piles with a 1000V voltage platform.
- Do not strike the charging equipment or place the charging equipment near a heat source.
- Do not pull or twist the charging cable.
- If there are large fluctuations in the power grid while the vehicle is charging, the charging power will also fluctuate and may even be suspended.
- Do not fast charge and slow charge the vehicle at the same time to avoid damaging the vehicle.
- Before the vehicle is parked for a long period of time, please ensure that the battery level is within a sufficiently charged range (50%~80%); maintenance must be performed once every 1 month. The specific operation is: fully charge the power battery and then discharge it to 80%. Failure to operate according to the specifications may cause over-discharge of the power battery, reduce the performance of the power battery, or even cause damage, which may lead to serious faults and damage to vehicle components, and will not be covered by the warranty.
- It is recommended that the first 3 charges after picking up the car use AC slow charging to charge the battery level to 100%, which helps to maintain the battery's healthy status.
- In order to avoid high state-of-charge floating charging affecting the health of the battery, if you need to charge the vehicle again when it is at a very high battery level (97% or above), you need to consume part of the battery level first before charging normally.
- Do not expose the charging connection device to direct sunlight or use it in a sealed environment.
- Charging is prohibited when the charging cable is in a damaged status.
- Use an outlet with reliable grounding.
- Please use a power supply with leakage protection.

### WARNING

Be sure to observe the following to avoid electric shock incidents or serious injury:

- It is prohibited to close the charging port cover plate when the vehicle's charging port protective cover is open.
- Unauthorized modification of vehicle charging system components and onboard charging equipment is strictly prohibited, as this may result in electric shock injury or even life-threatening injury.
- It is strictly prohibited to carry out charging operations on vehicles in places where there are flammable gases, liquids, or sources of ignition.
- It is strictly prohibited to charge the vehicle outdoors during rainy days or thunderstorms, as this may result in damage to the vehicle or charging equipment.
- Do not charge the vehicle during thunderstorms to avoid lightning strikes.
- Before charging, please make sure that the charging equipment is not scratched, rusted, cracked, or that the surface of the charging port, cable, control box, and charger is not damaged or showing other abnormalities; if the surface of the socket is damaged, rusted, cracked, or loosely connected, do not charge; if there is any dust or moisture on the above-mentioned charging equipment, or on the charging port, cable, charging box, etc., wipe it with a dry cloth until it is clean and then carry out the charging operation.
- Do not touch the charging port, charging connector, or metal connections of the charger while charging.

- If there is odor or smoke during charging, please stop charging immediately and contact the authorized dealer.
- After charging is complete, do not disconnect the charging connection device with wet hands or while standing in water, to avoid electric shock causing personal injury.
- If you are using any medical electrical devices, such as a pacemaker or implantable cardioverter defibrillator, please confirm with the manufacturer of the medical electrical device before initiating the vehicle charging process to ensure that the charging operation will not interfere with the normal use of the implanted device.

- It is strictly prohibited to disassemble or modify the charging port without authorization.

## AC CHARGING CONNECTORS

### AC CHARGER (BRITISH TYPE G POWER PLUG)\*

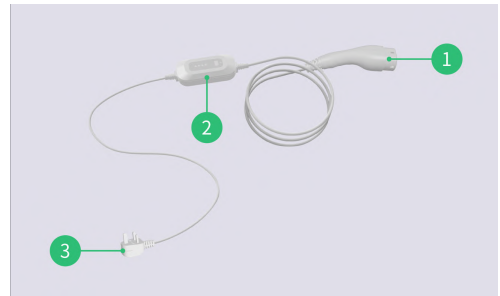

1. Charger
2. Control box
3. Power plug

### AC CHARGER (GB TYPE I POWER PLUG)\*

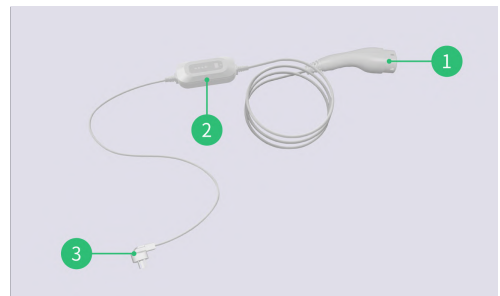

1. Charger
2. Control box
3. Power plug

### ⚠ ATTENTION

- If the battery level is discharged to 0%, please charge the vehicle immediately. At this point, charging speed may be slow until the power battery's battery level reaches 20% to restore battery performance. If the power battery is not recharged in time within 24 hours, it may cause irreversible damage to the power battery. If you are unable to charge the vehicle, please contact the authorized dealer immediately.

## CHARGING PORT

The charging port is located at the rear of the right side of the vehicle.

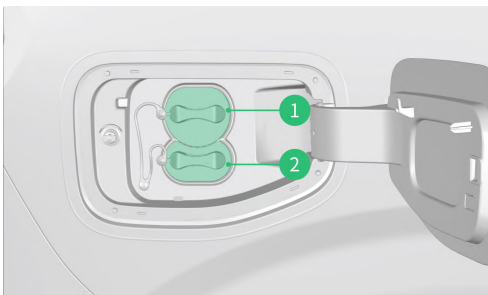

1. AC slow charging port
2. DC fast charging port

### ⚠ WARNING

### AC CHARGER (THAILAND, PHILIPPINES TYPE B POWER PLUG)\*

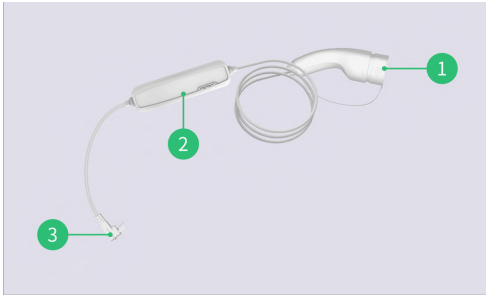

1. Charger
2. Control box
3. Power plug

### AC CHARGER (SOUTH AFRICAN TYPE M POWER PLUG)\*

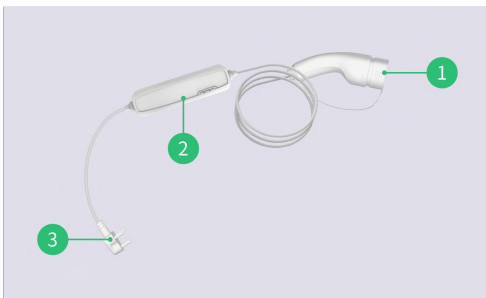

1. Charger
2. Control box
3. Power plug

### AC CHARGER (M3 DUAL-HEAD PLUG)\*



1. Power supply side charger
2. Vehicle side charger

#### **⚠ WARNING**

- Do not modify the AC charging connection device, otherwise it may easily cause danger.
- When the charging device malfunctions, do not attempt to resolve it yourself. It is recommended to contact the authorized dealer.
- Ensure that the power supply plug matches the power supply socket before charging.

#### **📌 NOTE**

- The charger should be covered with a protective cover when not in use.
- See the control box label for details on the charger control box indicator interpretation.
- See the product manual for details on how to use the charger.

## CHARGING METHODS

### INSPECTION BEFORE CHARGING

Please check the charging connection device and charge port before charging:

- Ensure that the charging connection device is not damaged, the connection cable is not worn, and the connecting plug is not corroded.
- Ensure that there are no water stains or foreign matters in the charging port and that the metal terminals are not rusty or corroded.

### HOW TO CHARGE

1. Open the charging port lid.



- After parking the vehicle steadily, shift the vehicle to P gear, apply the parking brake, and press the rear end of the charging port plate to open it.

2. Open the charging port protection cap.

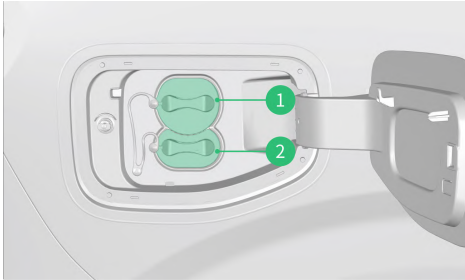

- When performing AC slow charging, open the AC slow charging port protection cap ①.
- When performing DC fast charging, open the AC slow charging port protective cover ① and the DC fast charging port protective cover ②.

3. Connect the charger.

- Connect the AC/DC charger to the charging port, and the connection is successful when you hear a "click" sound.

4. Start charging.

- Connect the power supply or start the charging pile, and the vehicle starts charging. During charging, the charger connection indicator in the instrument cluster goes on, and the charging screen is displayed; after the charging is over, the instrument cluster shows "Charging Completed".

5. Pull out the charger.

- Unlock the vehicle or unlock the charger on the infotainment screen, pull the charger out of the charging port, and place it properly. (Note: Fast charging is unlocked at the charging pile)

6. Close the charging port lid and the vehicle charging port cover.

- After charging, if you are unable to pull out the charger, please do not force the charger out, but contact Leapmotor Service Center or authorized dealer.
- Minors are prohibited from using charging equipment, and minors are prohibited from approaching during charging operations.
- Make sure the charging device is disconnected from the charging port when the vehicle is in motion.
- After charging, please be careful to close the protective cover, charging port lid, and cover plate to avoid rain, snow, or other foreign objects from entering.
- Please charge correctly according to the charging operation instructions. Flying wire charging and other operations are strictly prohibited to avoid safety incidents.

**NOTE**

- For the use of the portable charger unit, see the product manual.
- When the vehicle is charging, the radiator fan may automatically turn on and work, which is normal.
- Charging with the air conditioning system turned on will extend the charging time.

**EMERGENCY UNLOCKING OF AC SLOW CHARGING/DC FAST CHARGING**



If the charger cannot be pulled out after multiple unlock attempts during AC slow charging/DC fast charging, proceed with emergency unlocking operations:

1. Open the liftgate, remove the cover plate of the trunk, and take out the toolbox.

**ATTENTION**

- Do not flush the charging port while charging to avoid damage to the vehicle or charging equipment.

2. Find the AC slow charging/DC fast charging emergency unlocking mechanical cable, pull the unlocking cable, and then pull out the charger.

### SCHEDULED CHARGING\*

To facilitate your use of the vehicle, you can enable the scheduling slow charging function in the "Settings - Charging" interface on the infotainment screen. After the function is enabled, the charging time and charging limit priority function can be set.

#### NOTE

- For daily use, we recommend that you prioritize the scheduled charging mode, which will be beneficial to extend the life of the power battery and slow down the power battery degradation.
- Appointment charging is only available in scenarios where the vehicle is being charged using an AC charger.

### VEHICLE-TO-LOAD POWER DISCHARGE

#### DISCHARGE EXPLANATION

The vehicle has a function to discharge to external loads.

#### NOTE

- The vehicle is not equipped with a discharge connection device. If required, it is recommended to contact an authorized dealer.
- For the use of the discharge connection device, please refer to the corresponding discharge product instruction manual.

### INSPECTION BEFORE DISCHARGING

Please check the discharge connection device and charging port before discharge:

- Ensure that the discharge connection device is not damaged, the connection cable is not worn, and the connecting plug is not corroded.

- Ensure that there are no water stains or foreign matters in the charging port and that the metal terminals are not rusty or corroded.

### DISCHARGE OPERATION INSTRUCTIONS

1. The vehicle is in a power-on status.
2. Open the charging port lid cover plate and the AC slow charging port protective cover.
3. Connect the discharge connection device to the AC slow charging port, and then connect the external device.
4. In the "Settings - Charging - Discharging" interface of the infotainment screen, you can set the limit value of external discharged electricity.
5. After discharging, in the "Settings - Charging - Discharging" interface of the infotainment screen, tap "Discharge Plug Unlock" to turn off the vehicle's external discharging.
6. Unplug the discharge connection device, close the AC slow charging port protective cover and charging port cover plate, and place the discharge connection device properly.

#### WARNING

- Make sure the load status is off before discharging.
- Do not touch the discharge connection equipment while the vehicle is discharging, otherwise there may be a risk of electric shock.
- If there are any abnormal conditions during the discharge, such as odor or smoke, please stop using it immediately and contact the authorized dealer.
- Since inductive electrical equipment (such as electric drills, electric hammers, washing machines, large water pumps, electric welders, electric saws, and other motor and transformer equipment) has a high current during startup, which can easily cause transient overloading of the onboard inverter, thus affecting the service life of the inverter or even risking damage, the use of the above inductive electrical equipment is not recommended.
- It is prohibited to use discharge connection equipment that is defective, cracked, worn, ruptured, or otherwise damaged or inoperable.

- It is prohibited to use the discharge connection device when the vehicle is damaged or the connector is damaged.
- It is prohibited to open, disassemble, repair, tamper with, or modify the discharge connection equipment.
- It is prohibited to touch the end of the discharge connection device with sharp metal objects (e.g. wires, tools or needles).
- It is prohibited to damage the discharge connection equipment with sharp objects.
- It is prohibited to insert foreign objects into any part of the discharge connection device.
- The use of discharge connection equipment is prohibited during rain, snow, thunderstorms, or other inclement weather.
- Disconnect the discharge connection equipment when vehicle discharge is prohibited.
- If it rains during discharge, do not allow rainwater to flow along the cables and cause the discharge connection equipment or vehicle discharge port to become damp.
- Do not plug in the discharge connection device while the vehicle is in rain or snow. If the discharge connection device is plugged in and needs to be unplugged in this case, stop discharging and unplug the discharge connection device after the infotainment screen is unlocked.
- Be sure to protect the discharge connection equipment from dampness, water, and foreign matter. Do not use discharge connection equipment that is damaged or may be damaged or corroded.
- Do not use cleaning agents to clean the discharge connection device.
- If you are using any medical electrical devices, such as a pacemaker or implantable cardioverter defibrillator, please confirm with the manufacturer of the medical electrical device before initiating the vehicle discharge operation to ensure that the vehicle discharge will not affect the normal use of the implanted device.
- Ensure that the use of discharge connection equipment does not obstruct pedestrians, other vehicles, or objects.

** NOTE**

- Battery level below 20% cannot discharge externally.

## SEATBELT

### THE PROTECTIVE ROLE OF THE SEAT BELT

The vehicle and occupants in motion both have kinetic energy. The strength of the kinetic energy depends on the speed of the vehicle, the mass of the vehicle and its occupants; the greater the speed and mass, the stronger the kinetic energy released in a collision.

Drivers and occupants who do not wear seat belts will, due to inertia, continue to move forward at the pre-collision speed after a vehicle collision, while the vehicle does not move together with the drivers and occupants at this time, which may result in serious injuries to the drivers and occupants.

After fastening the seat belt, when the vehicle collides, the seat belt can restrain the driver and occupants in the proper position, slow down their forward inertia to prevent being thrown out, and ensure that the driver and occupants receive the best protection from the airbag, minimizing the impact injuries as much as possible.

#### **⚠ WARNING**

- Before every trip, every passenger in the vehicle must fasten their seat belt, and an appropriate child safety seat must be used for any child traveling with them.
- Even if the speed of the vehicle is low, the force acting on the human body in the event of a collision is very great, and the driver and occupants cannot control their bodies with their hands. Unbelted drivers and occupants may be thrown out and hitting any object inside the vehicle can cause serious personal injury.
- Rear seat occupants must also correctly wear the seat belt. Otherwise, occupants may be thrown violently when an incident occurs. Rear seat occupants not wearing seat belts can not only injure themselves but also endanger other occupants in the vehicle.
- Do not install decorations or devices on the seat belt that prevent the seat belt from locking, to avoid the seat belt failing to provide protection in the event of an incident.
- Do not tilt the seat backrest back too far, as this will seriously affect the protection of the seat belt.

- Do not let children play with the seat belt to avoid accidental injury.
- We recommend using seat belts for occupants who are ill, disabled, or otherwise impaired. You can also obtain effective advice by consulting your doctor.
- Do not place a cushion between the occupant's body and the seat backrest, as the cushion will affect the seating position and reduce the protective effect of the seat belt.
- Under no circumstances is it permitted to privately disassemble or modify the seat belt.
- Seat belts must be replaced when the incident vehicle is checked and repaired, regardless of whether they are damaged.

### CORRECTLY WEAR THE SEAT BELT

#### WEAR THE SEAT BELT

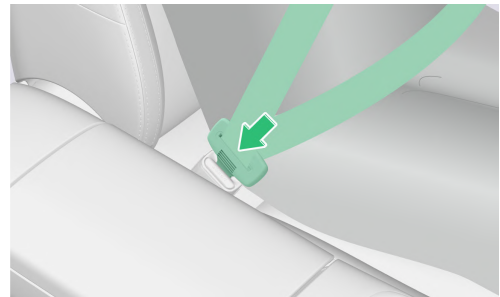

All seating positions in the vehicle are equipped with three-point seat belts. Please wear the seat belts correctly as follows:

1. Adjust the correct sitting posture.
2. Slowly and smoothly pull the seat belt out from the retractor, pass it over the chest and hips, and insert the deadlock into the corresponding latch until you hear a click.
3. Pull the seat belt deadlock to confirm that the seat belt deadlock is properly buckled.
4. Adjust the seat belt position so that the shoulder belt portion of the seat belt crosses diagonally over the entire shoulder, but does not touch the neck or slip off the shoulder, and so that the lap belt portion of the seat belt crosses as low as possible over the hips.

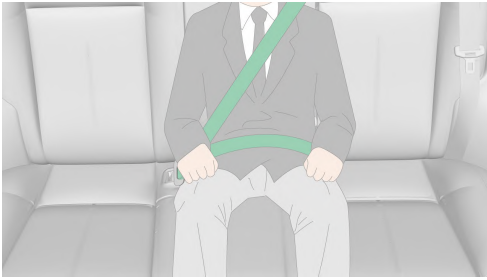

The rear seat also requires proper use of the seat belt.

#### ⚠ WARNING

- Ensure the seat belt is worn correctly; improper wearing of the seat belt increases the risk of injury or death in the event of a collision.
- Before fastening the seat belt, please ensure the seat is adjusted to the correct position.
- It is strictly forbidden to use seat belt latch plate substitutes to insert into the seat belt buckle to eliminate the seat belt unfastened warning.
- The seat belt lap belt portion being positioned too high or too loose may cause the occupants to slide during a vehicle collision or other accident, resulting in serious personal injury or even life-threatening harm.
- Do not place the seat belt under your arm, to avoid the seat belt failing to provide protection in the event of an accident.
- Do not fasten the seat belt over clothing with hard, fragile, or sharp objects, as this may increase the risk of injury or death.
- Each seat belt is limited to one person. Please do not share one seat belt with multiple people (including children).
- The seat belt is intended for use by adult-size occupants only. Children should sit in the rear seat and use a suitable child restraint system until their body size is large enough to wear a seat belt.
- A twisted seat belt cannot provide effective protection. In a collision, it may even cut you. Please ensure the seat belt lies flat against your body without twisting. If the seat belt cannot be fully extended, it is recommended to contact the authorized dealer.

#### 📌 NOTE

- Other seat belts are worn in the same way, and it is the driver's responsibility to remind other occupants to wear their seat belts properly.
- The seat belt must be fastened at all times while driving.

## UNBUCKLE THE SEAT BELT

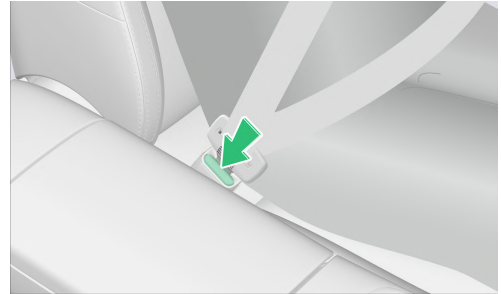

1. Hold the seat belt portion next to the buckle to prevent the seat belt from retracting too quickly.
2. Press the red unlock button on the seat belt buckle, and the deadlock will pop out.
3. Slowly feed the seat belt back into the retractor.

#### ⚠ WARNING

- It is prohibited to unbuckle the seat belt while the vehicle is in motion or before coming to a complete stop to avoid serious injury in the event of an accident.
- When the seat belt is not in use, it shall be fully retracted and shall not hang loosely. If the seat belt cannot fully retract, it is recommended to contact the authorized dealer.

#### ⚠ ATTENTION

- Take care to prevent foreign objects such as food crumbs, fruit shells, buttons, coins, sticky liquids, etc. from falling into the seat belt buckle. It may cause the seat belt reminder function and the latch locking or unlocking function to fail.
- To prevent the seat belt from rewinding too quickly and hitting surrounding areas or rewinding too slowly and getting stuck, please manually return the seat belt to its original position after unbuckling.

- Ensure the seat belt retracts smoothly. If the seat belt cannot retract smoothly, pull out the seat belt to check for twists or kinks.
- Before closing the door, make sure the door does not catch the seat belt. Otherwise the seat belt and door will be damaged.

## PREGNANT WOMEN SHOULD CORRECTLY WEAR THE SEAT BELT

When a pregnant woman wears a seat belt, place the shoulder belt portion evenly across the chest, position the lap belt portion as low as possible across the hips, keep the seat belt flat and snug, and do not place the shoulder belt portion or the lap belt portion over the abdomen.

### ▲ WARNING

- When driving a vehicle during pregnancy, the seat and steering wheel should be adjusted to make it easier to maintain control of the vehicle. In this case, you should try to adjust the seat position so that the distance between your abdomen and the steering wheel is as great as possible.
- When traveling in a vehicle during pregnancy, you should try to ride in the rear seat to avoid secondary injuries to the abdomen caused by the airbag in the event of an incident.
- If a pregnant woman uses the seat belt incorrectly, the seat belt may cause serious injury or even endanger the life of the mother and the fetus during emergency braking or a collision.

## SEAT BELT UNFASTENED WARNING



When the vehicle is moving, if the driver or occupant is not wearing a seat belt, the corresponding seat belt indicator light in the

instrument cluster will light up and be accompanied by a warning tone, until the seat belt is fastened, the indicator light will go out and the warning tone will stop.

### ▲ WARNING

- If the seat belt unfastened alarm function is abnormal, do not use the related seat, and contact the authorized dealer for check and repair.

### ◆ NOTE

- Before driving, please check whether there are heavy objects on the occupant seat to prevent the system from mistakenly assuming that an occupant is seated and issuing a false alarm.
- The instrument cluster buzzer beeps only when the vehicle reaches a specific speed and the front seat belts are not fastened.

## SEAT BELT INSPECTION AND MAINTENANCE

To confirm that the seat belts are functioning properly, the following three checks must be performed on all seat belts in the vehicle:

1. Fasten the seat belt, and quickly pull the seat belt at the position closest to the buckle; the buckle should remain securely locked.
2. Unbuckle the seat belt and fully retract the seat belt. Check whether the pulled-out seat belt is too loose, inspect the wear of the seat belt, and check if the seat belt retracts smoothly.
3. Pull the seat belt halfway out, hold the deadlock, and pull forward quickly. The retractor should lock automatically to prevent over-reeling.

If a seat belt fails any of the above checks, it is recommended to contact an authorized dealer.

### ▲ WARNING

- The seat belt should be checked for tangles both before and after use.
- If the seat belt has wear, is cut, or damaged in any other way, it is recommended to contact the authorized dealer.

- Seat belts need to be kept clean, and the sockets free of foreign objects that could interfere with the reliable engagement of the seat belt buckle.
- Do not insert objects similar to locking tabs into the socket to stop the seat belt alarm.
- Do not install, remove, modify, dismantle, or scrap seat belts privately. When repairs are required, it is recommended that you contact an authorized dealer.
- Before use, please carefully check whether the seat belt and seat belt fixing mechanism are broken or aging. If damaged, it is prohibited to continue to use, and it is recommended to contact an authorized dealer.
- Do not use solvent to clean the seat belt, use only neutral soap and warm water to clean the seat belt.
- Do not bleach or dye the seat belt, as this will severely weaken the strength of the seat belt. After cleaning, the seat belt should be wiped clean and dried in a cool place.
- Do not retract the seat belt into the retractor before it is completely dry.
- If the seat belt system does not work properly, such as the seat belt not retracting or locking, contact an authorized dealer immediately. Do not use the corresponding seat until the seat belt is repaired.
- Seat belt systems (including bolts) used in a vehicle involved in a serious collision incident must be replaced. The assembly should be replaced, even if it is slightly damaged.

## AIRBAG

### THE PROTECTIVE ROLE OF AIRBAGS

Airbags cannot replace seat belts; they are a component of the vehicle's overall passive safety protection system and serve as a supplement to the seat belt. Only when working together with a correctly worn seat belt can the airbag provide maximum protection.

The airbag is developed and matched for a specified vehicle model. Modifications to the suspension, tires, bumper, chassis, and original parts will adversely affect the airbag. Do not transfer any component of the airbag to another vehicle, as this may cause the airbag to fail, resulting in personal injury.

### WARNING

- When a vehicle experiences a severe collision, the airbag will deploy rapidly within a very short period of time; therefore, drivers and occupants must maintain the correct sitting posture and wear seat belts to avoid serious injury. In the event of emergency braking, the driver or occupant not wearing a seat belt may be thrown forward into the airbag deployment area, and the airbag deploying at high speed may cause injuries or even endanger the life of the driver or occupant.
- Do not fix, hang, or attach any objects in the airbag deployment area (instrument panel area, front seat, and the areas on both edges of the vehicle roof), otherwise these objects may injure the occupants when the airbag deploys.
- Front occupants must not hold children, pets, or objects, as the airbag may cause serious injury or even endanger life if triggered during an incident.
- Do not place luggage or other items under the front seats.
- Do not place your feet, knees, or any other part of your body over or near the airbag to avoid personal injury when the airbag deploys.
- Drivers and occupants are prohibited from leaning their heads or bodies against the doors. Otherwise, when the front-row side airbag or curtain airbag deploys, the body will be subjected to a strong impact, which can easily cause serious injury or even threaten life. Please be sure to pay attention especially when children are on board.
- The airbag system has strong anti-interference ability against surrounding electromagnetism, but to avoid accidents, do not use the vehicle in electromagnetic environments beyond those permitted by the state.
- If the airbag cover plate is cracked or damaged, do not use the vehicle and contact an authorized dealer immediately.
- Avoid touching the center of the airbag bracket or the inside of the airbag after the airbag has deployed.
- After the airbag deploys, the airbag component will become hot. Do not touch to avoid burns.
- Do not strike the airbag component to avoid accidental deployment of the airbag.
- The airbag system has fully taken into account various common misuse situations

and road conditions, but to avoid accidents, do not allow the vehicle's underside to be impacted or drive roughly in harsh road environments.

- Do not wet the seat backrest as this may prevent the side airbag system from functioning properly.
- Do not cover or replace the seat back cover yourself. Improperly fitting seatback cover replacements or covers can interfere with the deployment of the seat side airbag in a crash.
- Do not modify the steering wheel.
- Regardless of whether the seating position is equipped with an airbag or not, all drivers and occupants in the vehicle should always wear seat belts to reduce the risk of injury or death due to an incident.
- Do not modify the seat or its internal components.
- The airbag can only function once, and if triggered by an incident, it is recommended that you contact an authorized dealer.
- Do not alter the body structure of the vehicle or install crash protection devices on the front of the vehicle.

### AIRBAG LOCATION

Depending on the type of airbag and the installation location, airbags can be categorized as follows:

- Front row front airbags.
- Front row side airbags.
- Far-side airbag.
- Curtain airbag.

### FRONT ROW FRONT AIRBAGS



The driver seat front airbag is located on the steering wheel, with the airbag mark "AIRBAG" on the steering wheel. The front passenger airbag is located in the instrument panel in front of the front

passenger, and the instrument panel is marked with the "AIRBAG" airbag symbol.

In the event of a frontal collision, if the trigger conditions are met, the front row front airbags will deploy to help protect the head and chest of the vehicle occupants to minimize the extent of injury.

#### **▲ WARNING**

- Keep a distance of 25cm or more from the steering wheel when the driver is seated to avoid injury to the driver from the impact of the airbag deployment.

### FRONT ROW SIDE AIRBAGS

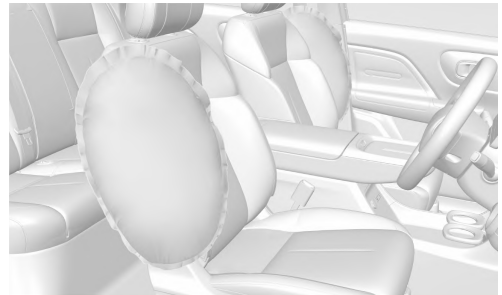

The front side airbag is located inside the seat backrest of the front seat near the door, and the seat is marked with the "AIRBAG" airbag symbol.

When the vehicle is involved in a side impact and the trigger conditions are met, the front row side airbag will deploy to provide additional protection to the front row occupants and reduce the extent of their injuries.

### FAR-SIDE AIRBAG

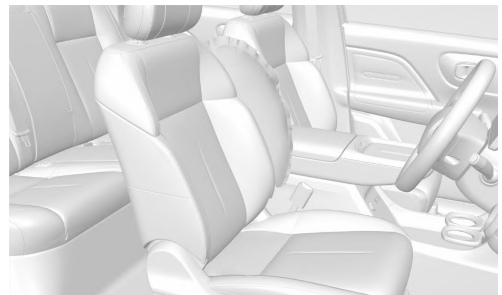

The far-side airbag is located in the front driver seat, inside the seat backrest on the side near the center armrest. The airbag symbol labeled

"AIRBAG" on the seat. When the vehicle experiences a side collision and the trigger conditions are met, the system activates the far-side airbag, causing it to deploy instantly to provide additional protection for the front-row occupant and reduce the severity of their injuries.

## SIDE AIR CURTAIN

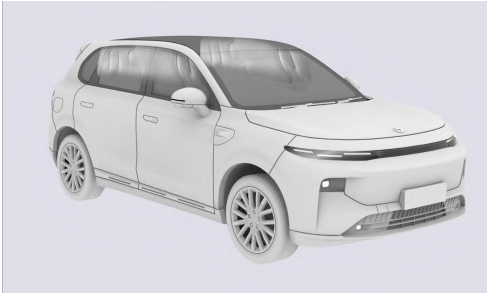

The curtain airbags are located on the left and right interior edges of the roof, and the airbag symbol with the word "AIRBAG" is marked on the interior trim panel on the A-pillar.

When the vehicle is involved in a side impact, the curtain airbags will deploy if the trigger conditions are met to provide additional protection to the driver and occupants to minimize the extent of their injuries.

## AIRBAG MALFUNCTION INDICATOR LAMP

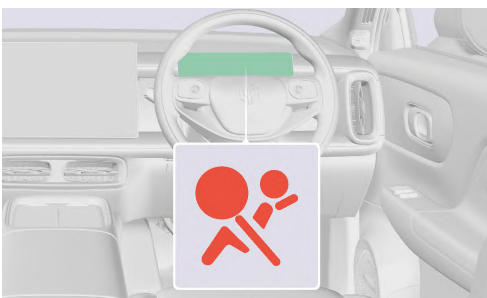

When the vehicle is powered up, the airbag malfunction indicator lamp (MIL) in the instrument cluster illuminates and goes out when the system completes its self-check. If any of the following occurs, it indicates a system fault:

- When the vehicle is powered on, the indicator light does not illuminate during the self-check.

- The indicator light does not go off after the vehicle is powered on and the system has completed its self-check.
- The indicator light illuminates while the vehicle is in motion.

### **⚠ WARNING**

- Do not attempt to repair, adjust, or modify the airbag.
- In the event of a fault in the airbag system, it is recommended that you contact an authorized dealer.

## CASES IN WHICH THE AIRBAG MAY DEPLOY

Cases in which the airbag may deploy:

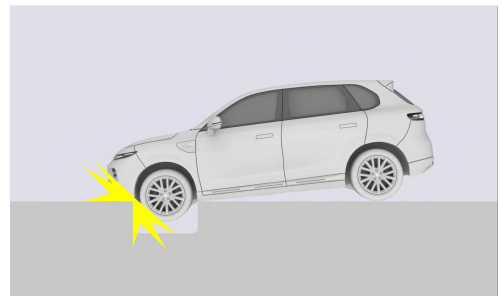

- The front of the vehicle strikes the ground when crossing deeper uneven road surfaces.

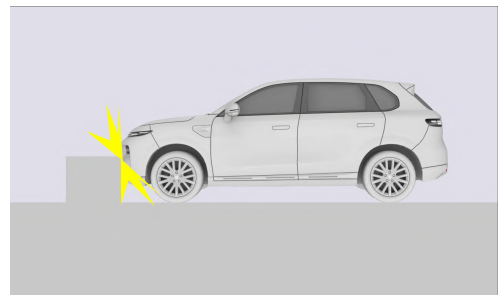

- Hit raised objects by the roadside, street stones, etc.

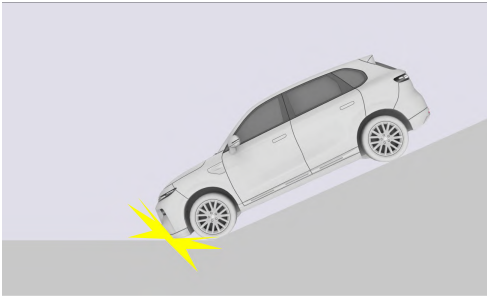

- The front of the car hit the ground when going down a steep slope.

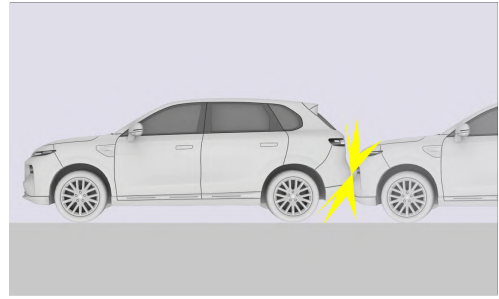

- The rear of the vehicle was rear-ended by another vehicle.

## CASES IN WHICH THE AIRBAG MAY NOT DEPLOY

Cases in which the airbag may not deploy:

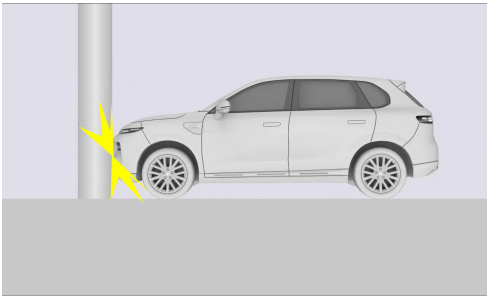

- Hit a tree, concrete pillar, or other slender object head-on.

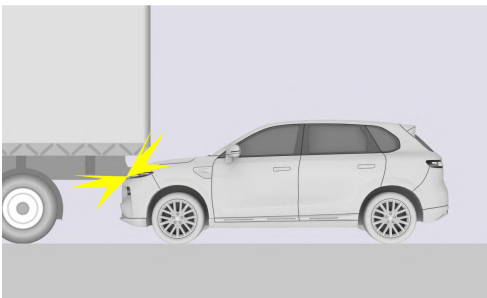

- Rear-ended and hit below the rear of a truck or other large freight vehicle.

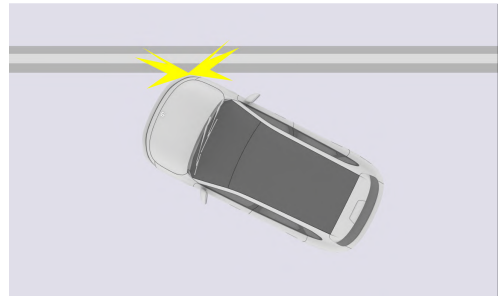

- Non-frontal collision with a vehicle or wall.

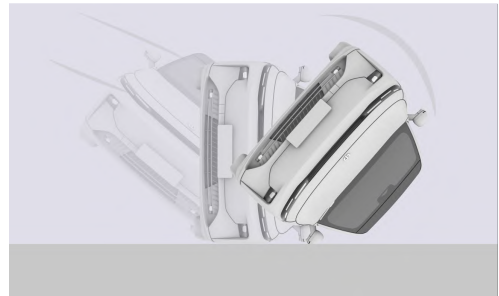

- The vehicle rolls over.

### NOTE

- The above list is not exhaustive. The vehicle is equipped with a collision intensity sensor that determines whether each airbag deploys based on the intensity and angle of the collision.

## REPLACEMENT OF AIRBAG SYSTEM COMPONENTS

If the airbag system does not work properly, it will not be able to protect the occupants of the vehicle in the event of an incident, which can lead to serious injuries or even threaten life. To ensure that the airbag system can function properly after a crash incident, airbags should be checked periodically and replaced if necessary.

### WARNING

- It is strictly prohibited to privately repair, adjust, or modify airbag components, harnesses, and software, otherwise it may cause the airbag system to fail to operate properly and may fail or activate unexpectedly in the event of an incident, increasing the risk of injury.
- If the airbag cover plate is cracked or damaged, do not use the vehicle and contact an authorized dealer immediately.
- Airbag systems deployed in a vehicle collision incident must be replaced.
- If the vehicle is scrapped, undeployed airbags pose potential dangers; therefore, they must be safely deployed by professionals in a controlled environment before scrapping.
- When selling or transferring your vehicle, make sure that the new owner is aware that the vehicle is equipped with airbags and the replacement date of the airbag system.

## CAR RESTRAINTS FOR CHILDREN

### INSTRUCTIONS FOR CHILDREN ON BOARD

When traveling with children under 12 years old or shorter than 1.5m, be sure to install safety seats or seat cushions for them, and ask the children to sit on the safety seats or seat cushions instead of being held or sitting on your laps to ensure their safety.

Use only licensed child safety seats that are appropriate for children and meet relevant regulations or standards. Check the label on the child safety seat when selecting one.

To ensure the safety of children on board, adult supervision is required at all times. Please choose the appropriate child restraint system in accordance with the children's figure. If it is necessary to place a rear-facing child safety seat on the front seat due to special circumstances, the front passenger airbag must be disabled! If necessary, the airbag can be turned off through the Infotainment Screen settings.

### WARNING

- Children under 15 months must be seated in a "rear-facing" child seat.
- When using a child safety seat, follow all installation instructions provided by the child safety seat manufacturer and properly install the child safety seat. Failure to install correctly may result in serious injury or even life-threatening injury to children during emergency braking, emergency turning, or in the event of an incident.
- Ensure that there are no hard or sharp objects on the child safety seat to avoid injuring the child in the event of an incident.
- Holding a child in your arms cannot replace the role of a child safety seat, and in the event of an incident, the child may hit the windshield or be crushed between the passenger and the compartment.
- Children sitting in a child safety seat must be supervised by an adult. Do not leave children alone in the vehicle to avoid accidental injuries.
- It is prohibited for children to stand inside the vehicle or kneel on the seat while traveling, otherwise in the event of an incident, the child may be thrown up, causing injuries to the child and other persons in the vehicle, or even endangering their lives.
- When the child safety seat is not in use, it must still be properly installed and secured in the vehicle to prevent the unsecured child safety seat from moving and injuring the vehicle occupants during a collision or emergency braking.
- Do not let the child's body (such as head and hand) stick out of the window while the vehicle is running.
- The child safety lock shall be used when children are seated in the rear seats.

### ATTENTION

- For effective protection of children, correctly choose a child safety seat according to the child's age, height, and weight, and use a seat belt or child safety seat to restrain and protect the child.

### AIRBAG WARNING LABEL



Extreme Hazard! Do not use a rearward facing child restraint on a seat protected by an airbag in front of it!

An airbag warning label on the front passenger side sun visor reminds the front passenger of the dangers of airbag expansion, and the rear-facing child restraint system shall not be used in seats protected by frontal airbags (in the activated state). Be sure to read and follow the instructions on the label.

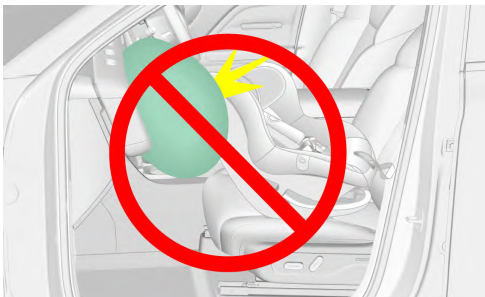

NEVER use a rearward facing child restraint on a seat protected by an ACTIVE AIRBAG in front of it, DEATH or SERIOUS INJURY to the CHILD can occur.

### ⚠ WARNING

- Do not install a rear-facing child safety seat on the front passenger seat without turning off the passenger airbag. Otherwise, in the event of an accident, the impact force of the rapid deployment of the passenger front

airbag may cause serious injury or even life-threatening to the child.

### DISABLE FRONT PASSENGER AIRBAG\*

Do not install a rear-facing child safety seat on a seat protected by a front airbag in the activated status. Otherwise, in the event of an incident, it may cause serious injury or even be life-threatening to the child.

If it is necessary to place a rear-facing child safety seat on the front passenger seat due to special circumstances, the front passenger airbag must be disabled.

### FUNCTION OPERATION

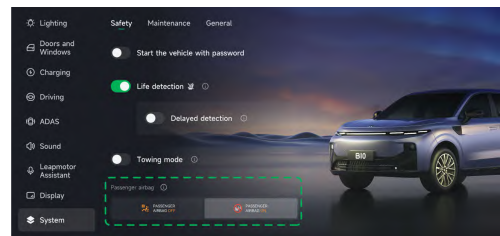

On the “Settings - System - Safety” interface of the Infotainment Screen, tap the front passenger airbag on/off button to turn it on/off.

The top bar of the infotainment screen will simultaneously display an icon indicating the on/off status of the front passenger airbag.

### ⚠ ATTENTION

- When the vehicle is powered on, the last on/off status of the front passenger airbag will be memorized.
- After turning off this switch, the front passenger airbag will not deploy under any circumstances. Please choose whether to turn it off carefully.

## CHILD SEAT SELECTION RECOMMENDATIONS

There are different types of child seats on the market, and it is recommended to use an approved child seat that is suitable for your child.

### ⚠ WARNING

- Please choose a suitable child seat for your child.
- If the child is too big to use a child seat, they should sit in the rear seat and use the seat belt properly.

Recommended child seats: ECE-R129 classification is based on the child's height.

Height	Manufacturer	Model	Connections
40cm - 83cm	Maxi Cosi	Pebble 360	Seat Belt
76cm - 105cm	Britax Römer	TriFix2i-size	ISOFIX and Top Tether
100cm - 150cm	Britax Römer	Kidfix i-Size *	ISOFIX and Seat Belt
120-150 cm	Graco	Booster Basic	Seat Belt

\*For better protection, it is recommended to use this child restraint system with backrest and ensure the seat belt is connected through the safety guard and XP-pad.

## INSTALLING THE ISOFIX CHILD RESTRAINT SYSTEM

### ISOFIX CHILD SEAT INTERFACE



The ISOFIX child seat interface is located in the gap between the rear seat backrest and the seat cushion.

### TOP TETHER ANCHORAGE

#### Status 1\*

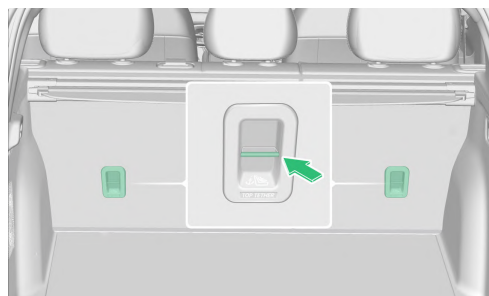

The top tether anchorage is located on the back side of the rear seat backrest.

#### Status 2\*

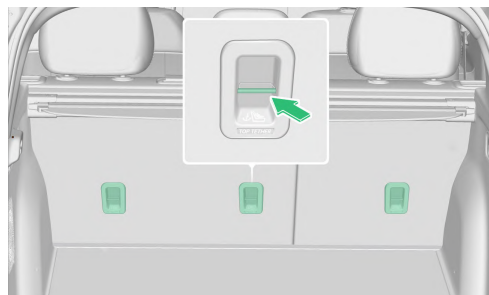

The top tether anchorage is located on the back side of the rear seat backrest.

## INSTALLING A CHILD SEAT BY USING THE ISOFIX CHILD SEAT ANCHORAGES AND TOP TETHER ANCHORAGES

1. Move the front seats to their full forward position.

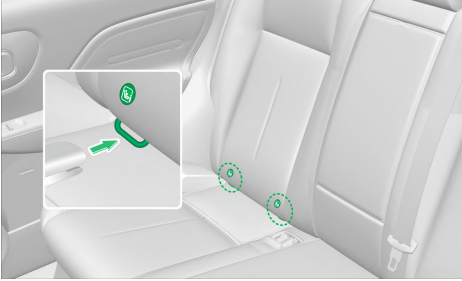

2. Slide child seat locking mechanisms into the lower fixing point and ensure that both ISOFIX locking mechanisms are correctly secured.

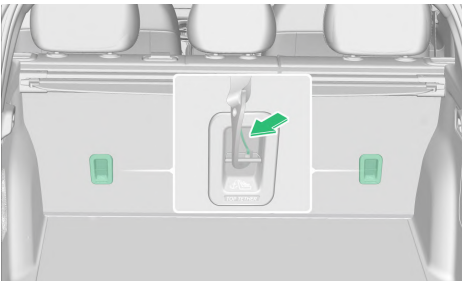

3. Press and hold the spring, then pass the top tether through the top tether anchorage on the back of the backrest. Be careful not to twist the top tether strap. When securing, be sure to pass the top tether strap under the headrest. If the headrest interferes with the installation of the child safety seat, remove it or raise it to the highest position.
4. Tighten the top tether strap, and push and pull the child seat in different directions to make sure that it is fixed securely.

### **⚠ WARNING**

- Do not continue to adjust the seat after the child safety seat installation is complete, as this may cause the child safety seat to shift and fail to provide protection.
- Child restraint anchorages are designed to withstand only those loads imposed by

correctly fitted child restraints. Under no circumstances are they to be used for adult seatbelts, harnesses, or for attaching other items or equipment to the vehicle.

- Do not secure more than one child safety seat with a single seat belt or a single fixing port. The added load of multiple seats can damage seat belts or fixing ports, causing serious injury or even endangering life.

### **🔑 NOTE**

- The illustration shows an example of a rear seat equipped with 2 Top tether interfaces. The installation method for child seats on rear seats equipped with 3 Top tether interfaces is the same. Please refer to the actual vehicle for details.

## INSTALLING A CHILD SEAT USING ISOFIX FIXING POINT AND THE CHILD SEAT SUPPORT LEG

1. Install the child seat on the base and lower the supporting legs according to instructions for child seat.



2. Place the child safety seat on the rear seat, find the lower fixing point, and insert the lower mounting guide groove of the child safety seat into the lower fixing point in the seat cushion gap until a meshing sound is heard.
3. Adjust the length of the lower supporting legs, so that they can be fully supported on the floor of the vehicle. When the installation of the supporting legs is completed, the panel will display green (otherwise it will display red), or you will hear a "beep" sound.

## INFORMATION ON THE APPLICABILITY OF CHILD RESTRAINT SYSTEMS

Only child safety seats that are licensed and applicable to children are allowed to be used. Children who are more than 1.5m tall can use vehicle seat belts like adults. If a child safety seat is needed, it shall comply with relevant regulations or standards.

Seat position	Driver	Front row passenger		Rear left seat (*a)	Rear center seat (*a)	Rear right seat (*a)
		Passenger airbag off	Passenger airbag on			
Seat position suitable for universal seat belts (Yes/No)	No	Yes	Yes (*b)	Yes	Yes	Yes
Seat position suitable for i-Size (Yes/No)	No	No	No	Yes	No	Yes
For fixed positions of lateral clamps (L1/L2/No)	No	No	No	No	No	No
Maximum suitable backward clamp (R1/R2X/R2/R3/No)	No	No	No	(R1/R2X/R2/R3)	No	(R1/R2X/R2/R3)
Maximum suitable forward clamp (F1/F2X/F2/F3/No)	No	No	No	(F1/F2X/F2/F3)	No	(F1/F2X/F2/F3)
Maximum suitable booster cushion fixing device (B2/B3/No)	No	(B2/B3) (*c)	(B2/B3) (*c)	(B2/B3)	(B2/B3) (*c)	(B2/B3)

Notes:

(\*a): The headrest can be adjusted or removed if desired, but do not remove the headrest when using an enhancement cushion without a seat backrest.

(\*b): Only applicable to forward-facing child seats.

(\*c): Only for installation of seat belts.

## INSTRUMENT CLUSTER

### INSTRUMENT CLUSTER DISPLAY INFORMATION



- |                        |  |                      |
|------------------------|--|----------------------|
| 1. Speedometer         | 2. Right information display screen      | 3. Power meter       |
| 4. Gear                | 5. State of capacity and driving mileage | 6. Acceleration mode |
| 7. Outdoor temperature | 8. Time display                          |                      |

Speedometer: Displays the current vehicle speed in km/h.

Right side information display: Displays navigation\*, entertainment, and mileage information.

Power meter: Displays the current power of the drive motor in kW.

Gear: Displays the vehicle's current gear.

State of capacity and driving mileage: Displays the driving mileage that can continue to be driven with the current state of capacity.

Acceleration mode: Displays the vehicle's current acceleration mode.

Outdoor temperature: Displays the vehicle's outdoor temperature.

Time display: Displays the current time.

#### NOTE



- Driving mileage may be shorter due to environmental and driving factors, refer to the actual mileage of the vehicle.
- Please strictly abide by traffic regulations. Do not speed.

## INSTRUMENT CLUSTER INDICATOR

Icon	Name	Explanation
	Left direction indicator lamp indicator	When the left direction indicator lamp is on or the hazard warning lamp is activated, this indicator goes on.
	Right direction indicator lamp	When the right direction indicator lamp is on or the hazard warning lamp is activated, this indicator goes on.
	Position lamp indicator	This indicator goes on when position lamps are on.
	Daytime running lamp indicator	This indicator goes on when the daytime running lamp is on.
	Front fog lamp indicator	This indicator goes on when the front fog lamp is on.
	Rear fog lamp indicator	This indicator goes on when the rear fog lamp is on.
	Low beam indicator	This indicator goes on when the low beam is on.
	High beam indicator	This indicator goes on when the high beam is on.
	Auto high beam on indicator	This indicator goes on when the auto high beam is on.
	Auto high beam active indicator	This indicator goes on when the auto high beam is active.
	Auto high beam fault indicator	This indicator goes on when the auto high beam is faulty.
	Lamp fault indicator	This indicator goes on when the lamp is faulty.
	Driving range indicator	Shows the range that the vehicle can travel with the current battery level.
	Timed charging indicator*	Timed charging is set on the infotainment screen. After the charger is connected, this indicator goes on.

Icon	Name	Explanation
	Front left seat belt unfastened warning indicator	When the front left seat is occupied and the seat belt is not fastened, this indicator goes on.
	Front right seat belt unfastened warning indicator	When the front right seat is occupied and the seat belt is not fastened, this indicator goes on.
	Rear seat belt unfastened warning indicator	When the rear seat is occupied and the seat belt is unfastened, this indicator goes on.
	Electronic parking brake indicator	When the electronic parking brake works, this indicator goes on. When the electronic parking brake is faulty, this indicator flashes.
	Electronic parking brake fault indicator	When the electronic parking brake is faulty, this indicator goes on.
	Anti-lock brake system fault indicator	When the anti-lock brake system is faulty, this indicator goes on.
	Hydraulic brake assist/brake system fault indicator	When there is a minor fault in the hydraulic brake assist/brake system, this indicator goes on. Although it does not affect safe driving, you should contact the authorized dealer as soon as possible.
	Electronic brakeforce distribution system fault/brake fault/low brake fluid level indicator	When the electronic brakeforce distribution system or brake is faulty, or the brake fluid level is low, this indicator goes on, which may affect safe driving. Please park safely and contact the authorized dealer.
	Power limit indicator	When the motor power is limited, this indicator goes on.
	Charger connection indicator	When the charger is connected, the indicator turns on.
	Tire pressure fault indicator	When the tire pressure system is abnormal, or any tire pressure signal is abnormal, leaking, overpressure or underpressure, overheating, or low battery level, this indicator goes on.
	Airbag malfunction indicator lamp	When the airbag is faulty, this indicator goes on.
	Door status indicator	When the door is opened, this indicator lights up.
	Bonnet/liftgate status indicator	This indicator illuminates when the bonnet or liftgate is open.

Icon	Name	Explanation
	Electronic stability control system/traction control system/anti-rolling system status indicator	When any function of the electronic stability control system / traction control system/anti-rolling system is faulty, this indicator stays on. When any function of the electronic stability control system/traction control system/anti-rolling system is activated, this indicator goes on.
	Electronic stability control off indicator	This indicator goes on when the electronic stability control is turned off.
	READY indicator	After the vehicle starts, this indicator illuminates.
	Battery SoC indicator	When the battery is being discharged, this indicator goes on.
	Low power battery level insufficient indicator	This indicator goes on when the power battery level is low.
	Power battery fault indicator	This indicator illuminates when the power battery experiences a fault.
	High power battery temperature indicator	When the power battery temperature is high, this indicator goes on.
	Full-speed adaptive cruise control available status indicator	When adaptive cruise control is available, this indicator turns on.
	Full-speed adaptive cruise control active indicator	When adaptive cruise control is active, this indicator illuminates.
	Lane assist system available status indicator	The indicator illuminates when the lane assist system is available.
	Lane assist system active indicator	The indicator illuminates when the lane assist system is active.
	Lane assist system pause status indicator	When the lane assist system works, the system enters a pause status when crossing an intersection, etc., and this indicator goes on.
	AEB fault indicator	When the AEB is faulty, this indicator goes on.
	AEB unavailable indicator	The indicator light illuminates when automatic emergency braking (AEB) is in an unavailable status.

Icon	Name	Explanation
	AEB off indicator	When the driver actively turns off the AEB system, this indicator goes on.
	Speed limit sign recognition indicator*	When a speed limit sign is recognized, this indicator goes on.
	Speed limit sign recognition indicator*	When there is no speed limit, this indicator goes on.
	Speed limit sign recognition indicator*	When an unreliable speed limit sign is recognized, this indicator goes on.
	Speed limit sign recognition indicator*	When the overspeed alarm sound is off, this indicator goes on.
	Speed limit sign recognition off indicator*	When the speed limit sign recognition is off, this indicator goes on.
	Speed limit sign recognition fault indicator*	When the speed limit sign recognition is faulty, this indicator goes on.
	System fault indicator	This indicator illuminates when the system experiences a fault.
	Electric drive high temperature indicator	When the electric drive temperature is high, this indicator goes on.
	Motor control unit fault indicator	This indicator illuminates when the motor control unit experiences a fault.
	Autohold on indicator	When the autohold function is turned on but not activated, this indicator goes on.
	Autohold fault indicator	This indicator goes on when Autohold has a fault.
	Autohold activation indicator	The indicator illuminates when Autohold is activated.
	Vehicle insulation fault indicator	When the vehicle insulation has a fault, this indicator goes on.
	Driver assistance function fault indicator	When the driver assistance function is faulty, this indicator goes on.

Icon	Name	Explanation
	Hill descent control activation indicator	When the hill descent control is activated, this indicator flashes.
	Hill descent control fault indicator	When hill descent control is faulty, this indicator goes on.
	STOP indicator	This indicator illuminates when the vehicle experiences a fault.
	Driver monitoring system activation indicator	When driver monitoring system warning is activated, this indicator goes on.
	Distraction warning activation indicator	When the distraction warning system is activated, this indicator goes on.
	Driver monitoring system/distraction warning system fault indicator	This indicator lights up when a recoverable short-term fault occurs in the driver monitoring system/distraction warning system (e.g., camera is obscured).
	Driver monitoring system/distraction warning system fault indicator	This indicator lights up when an irrecoverable long-term fault occurs in the driver monitoring system/distraction warning system (e.g., camera open circuit).
	Electric power steering fault indicator	When the electronic power steering has a fault, this indicator goes on.
	Lane departure warning/lane keeping assist function fault indicator	The indicator illuminates when the lane departure warning or lane keeping assist has a fault.
	Lane departure warning/lane keeping assist activation condition met indicator	The indicator illuminated when the lane departure warning or lane keeping assist meets the activation condition.
	Lane departure warning/lane keeping assist off indicator light	The indicator illuminates when the lane departure warning/lane keeping assist function is off.

#### NOTE

- After the vehicle is started or when it is running, if an indicator goes on or flashes, it means that the relevant system is in a certain working state or faulty. You should read and understand the meaning of each indicator lamp in detail. In case of a fault, please contact the nearest authorized dealer.
- Due to differences in vehicle configurations and later OTA upgrades, the interface of the instrument cluster may be changed. Please refer to the actual vehicle for display.

## INFOTAINMENT SCREEN

### MAIN INTERFACE DISPLAY INFORMATION



1. Top bar

2. Quick access

3. Bottom bar

Top bar: Displays time, Bluetooth, mobile phone wireless charging, fault alarm, network\*, etc.

Quick access: Displays shortcut cards for navigation\*, multimedia, vehicle status, etc.

Bottom bar: The icon options in the bottom bar of the illustration, from right to left, are Main Interface, App Center, Settings, Navigation\*, Music, 360 Around View, A/C Temperature Adjustment, A/C On/Off, Front Windshield Defrost, Rear Windshield Defrost, Inside Air/Outside Air and Volume Adjustment.

Through the "Vehicle Settings-Display-Customize Bottom Bar" interface, you can customize the applications on the bottom bar, as well as the display and order of the control functions and status.

#### **WARNING**

- For your driving safety, do not operate the infotainment screen while driving.

## QUICK ACTIONS

Swipe down from the top of the infotainment screen to display the "Quick Actions" screen.

On this interface, you can quickly set the following functions:

- Quick action: adjust the screen brightness, one key to turn off the screen, liftgate, rearview mirror adjustment, dark mode/light mode switching, guard mode, camp mode and many other functions.
- Edit Quick Action: Tap the "Edit" button on the Quick Action interface, or long press the cell to edit the Quick Action bar. Tap the upper right corner of the cell to add or delete, long press the cell and drag to edit the position.

## VEHICLE SETTINGS

By tapping the Settings button on the bottom bar of the infotainment screen or the App Center Settings icon , you can achieve control of Lights, Doors & Windows, Charging, Driving, Smart Driving, Sound, Leapmotor Assistant, Display, System and other functions.

### LIGHTING

In the "Lights" screen, you can tap to set the following functions:

- Turn off all lights, turn on position lamps, low beam, and automatic headlamp.
- Turn on or off the front fog lamp.
- Turn rear fog lamp on/off.
- Headlamp height adjustment.
- Turn auto high beam on or off.
- Turn the lighting delay on or off.
- Turn the auto reading light on or off.
- Turn the light language on or off.

You can set the following functions in the ambient light\* interface:

- The ambient light can be set to Off, On, or Automatic.
- Set ambient light color.
- Ambient light effects: static, single-color flashing, color-changing flashing.
- Set ambient light brightness.
- Turn on or off ambient light.
- Turn music rhythm on or off.

### DOORS AND WINDOWS

On the "Window & Door" screen, you can tap to set the following functions:

- Window lock: when opened, the front passenger side and rear seat occupants cannot operate the corresponding side window.
- Window adjustment: controls the driver seat side and front passenger side windows to the fully open, fully closed, and ventilated positions.
- Window when locking the car: can be set to close window, current status, ventilation.
- Sunshade: You can control the sunshade to be fully open, fully closed, or slide to set the sunshade opening degree.
- Liftgate: Allows you to open or close the liftgate\* and set the height of the liftgate\*.

### CHARGING

In the "Charging" interface, you can check the battery information and the connection status of the charger, and touch to set the following functions:

- Charge limit: Adjust the charge limit.
- Charger unlock: tap the charger unlock icon to unlock the charger.
- Safety Current Limit: When the function is turned on, the maximum current of the portable charger is limited to 8A to ensure charging safety.
- Scheduling slow charging\*: After enabling the scheduling slow charging function, you can set the start time, end time, repeat cycle, and enable or disable the charging limit priority function.
- Driving range condition: can be selected as standard or dynamic.

In the "Discharge" interface, you can check the battery information and the connection status of the discharging device, and tap to set the following functions:

- Discharge limit: Adjust the external discharge limit.

- Discharge Plug Unlock: Tap the Discharge Plug Unlock icon to unlock the discharge gun.

## DRIVING

In the "Driving" screen, you can tap to set the following functions:

- Acceleration Mode: can be set to Comfort, Standard or Sport Mode.
- Energy recovery: can be set to weak, medium, or strong.
- Steering mode: can be set to comfort, standard, and sports mode.
- Mirror Adjustment: The angle of the left/right exterior rearview mirrors can be adjusted via the left/right wheel on the steering wheel. You can control the unfolding/folding of the rearview mirrors\*, set the rearview mirror heating/rearview mirror auto-heating function, and set the rearview mirror autofolding/unfolding function\*.
- Steering wheel custom button: The custom button on the steering wheel triggers function when clicked or double clicked, which can be set as Front Defroster, Rearview Mirror Adjustment, 360 Around View, Rearview Mirror Folding\*, Window Lock, and Rearview Mirror Heating.
- Maximum Speed Limit: You can turn on or off the maximum speed limit function. After the function is turned on, you can set the upper limit of the vehicle's driving speed. During driving, you cannot switch the function on or off or adjust the speed limit, and some advanced driver-assistance system (ADAS) functions will be restricted.
- Crawl Control: Crawl control can be turned on or off. When the mode is on, release the brake pedal and the vehicle moves forward slowly.
- Autohold: allows you to turn the autohold function on or off. When the function is turned on, the vehicle automatically activates autohold when parked to avoid the vehicle from coasting.
- Electronic Stability Control (ESC): Tap the button to enable or disable the electronic stability control (ESC). Turning off the electronic stability control (ESC) increases the risk of loss of vehicle control, so please be careful when turning it off.
- HDC Hill Descent Control: HDC Hill Descent Control can be turned on or off. When the function is turned on, it assists the vehicle in descending steep slopes smoothly.
- Comfort Braking: The comfort braking function can be turned on or off. When the function is enabled, it reduces nodding caused by braking and improves driving comfort.
- Automatic wiper sensitivity adjustment\*: can be set to low, medium, or high.
- Intermittent wiper speed setting\*: can be set to slow, medium, fast, extreme.

## SMART DRIVING

In the "Smart Driving - advanced driver-assistance system (ADAS)" interface, you can tap to set the following functions:

- Lane Centering Assist: can be turned on or off. When the function is turned on, the system actively provides steering force to keep the vehicle continuously in the middle of the lane during driving. At this time, the driver must always keep an eye on the environment and road conditions, and always keep their hands on the steering wheel to ensure safe driving.
- Intelligent Speed Assistance (ISA)\*: You can turn on or off the Intelligent Speed Assistance (ISA) function. When the function is turned on, you can choose to enable or disable the speed limit change beep, overspeed alarm, overspeed alarm sound, and speed limit control.

In the "Smart Driving - Active Safety" interface, you can tap to set the following functions:

- Forward Collision Warning (FCW): the forward collision warning function can be turned on or off. When the function is turned on, the forward collision warning (FCW) sensitivity can be set to low, medium, or high. During the vehicle's traveling, when the system detects that the distance to the vehicle in front is less than the safe distance and there is a risk of an emergency collision, it will remind the driver through an alarm screen and alarm tone.
- AEB: The AEB function can be turned on or off. When the function is turned on, during the vehicle's driving process, if the vehicle encounters vehicles, pedestrians, obstacles, or other targets ahead, and the driver does not provide sufficient braking force to slow down the vehicle, and the system detects a danger, it will actively provide braking force to avoid or reduce the risk of collision.

- Lane Departure Warning and Assist: You can turn the lane departure and assist warning function on or off. When the function is turned on, you can set the level of assistance to Warning, Hold, Warning+Hold, set the Lane Departure Warning sensitivity to Low or High, and choose to turn on or off the warning sound and steering wheel vibration.
- Emergency Lane Keeping Assist: You can activate or deactivate the Emergency Lane Keeping Assist function. When the function is turned on, during vehicle movement, if the vehicle is about to cross the lane line, or there is a risk of collision with an oncoming vehicle in an adjacent lane, a vehicle behind, or the edge of the roadway, the system will actively intervene in the steering wheel control to make corrections to avoid a collision. This process still requires the driver to focus on driving and always pay attention to the surrounding environment.
- Blind Spot Warning (BSW): the blind spot warning function can be turned on or off. When the function is turned on, the system monitors other vehicles approaching from the side and side rear in real time while the vehicle is in motion, and alerts the driver to collision hazards through the blind spot detection warning light on the exterior rearview mirror.
- Door opening warning (DOW): the door opening warning (DOW) function can be turned on or off. When the function is turned on, the system monitors targets such as other vehicles, cyclists, or pedestrians to the side and rear of the vehicle while the vehicle is in a parked status, and alerts the driver and occupants through the blind spot detection warning light on the exterior rearview mirrors when a collision hazard may occur due to door opening.
- Rear Collision Warning: Can enable or disable the rear collision warning function. After the function is turned on, when the system monitors other vehicles approaching from the rear and there is a risk of collision while the vehicle is in motion, the system will send out a warning message and turn on the hazard warning lamp to remind the vehicle behind to slow down or keep a safe distance.
- Rear cross-traffic alert (RCTA): you can turn on or off the rear cross-traffic alert function. When the function is turned on, you can select the assistance level as Warning or Warning + Braking.
- Distraction warning system: you can turn on or off the distraction warning function. After the function is turned on, during normal vehicle driving, when the system detects that the driver's attention has left the current driving task and determines it to be dangerous driving behavior, the system issues a warning prompt through the dashboard and central control to help the driver maintain focus on the current traffic situation.

In the "Smart Driving - Assisted Imaging" interface, you can tap to set the following functions:

- Steering Assist Image: The steering assist image function can be turned on or off. When the function is turned on, the 360-degree image side and rear 3D image is automatically turned on when the turn signal is turned on.
- Start Assist Image: The start assist image function can be turned on or off. When the function is turned on, the system will automatically turn on the 360-degree image when the vehicle is shifted from Park (P) to D gear to assist the driver in observing the surrounding environment.
- Ramp Assist Image: The ramp assist image function can be turned on or off. After the function is turned on, if the vehicle is detected to be on an uphill section during the driving process, the system will automatically turn on the 360 image to assist the driver to view the environment in front of him.

## SOUND

On the "Sound" screen, you can set the following functions:

- Volume Adjustment: Tap to adjust media, navigation\*, phone, and voice volume.
- Touch Tone\*: Tap to turn the touch tone function on or off.
- Shift beep: Tap to turn the shift beep function on or off.
- Latching Horn: Tap to turn the latching horn function on or off.
- Vehicle mute when reversing: tap to turn on or off the vehicle mute function when reversing.
- Reduce Media Volume While Navigating\*: Tap to turn the Reduce Media Volume While Navigating feature on or off.
- Lower Media Volume When Door Opens: Tap to turn the Lower Media Volume When Door Opens feature on or off.

In the "Sound Effects" screen, you can set the following functions:

- Sound Field Area\*: can be set to full car, front seat, or rear seat.

- Sound Mode: Can be set to Leap-tone enjoyment, Leap-tone surround, Leap-tone theater, or Leap-tone dynamic.
- Equalizer: can be set to Custom, Pop, Rock, Classical, Dance, Jazz and other equalizer statuses.

### LEAPMOTOR ASSISTANT

In the "Leapmotor Assistant" interface, you can tap to set the following functions:

- Voice activation: Tap to enable or disable the voice activation function. After turning it on, you can audition the wake word pronunciation and set the wake sound zone.
- Continuous dialog: can set the duration of continuous dialog after waking up.
- Wake-Free Voice: Tap to turn the Wake-Free Voice feature on or off. After the function is enabled, commands can be triggered without a wake word.
- List of Voice Tips: Tap the example button to view the list of voice tips.

### DISPLAY

On the "Display" screen, you can tap to set the following functions:

- Display Mode: can be set to light mode and dark mode.
- Auto Deep/Light Mode Switching: Tap to enable or disable the auto deep/light mode switching function. When the function is enabled, it can be set to switch based on ambient brightness or based on sunrise and sunset.
- Screen Brightness: Adjust the brightness of the screen display.
- Auto Brightness Adjustment: Tap to turn on or off the auto brightness adjustment function.
- Distance unit: can be set to km, mi.
- Screen cleaning: Tap to enable screen cleaning mode. When the mode is on, the entire vehicle screen will be turned off, preventing accidental touches during cleaning.
- Customize the bottom bar: You can customize the applications of the bottom bar, the display and arrangement order of the control functions and status.

### SYSTEM

In the "System - Security" interface, you can tap to set the following functions:

- Password start vehicle: Tap to enable or disable the password start vehicle function. If the operation password has not been set before enabling the function, you need to set the operation password first before you can enable the function.
- Life Detection\*: Tap to turn the Life Detection function on or off. When the function is turned on, it detects life forms left in the car after powering down and locking the car, and intelligently intervenes by alerting through lights, siren, and app as well as turning on the A/C. If you leave the vehicle temporarily, you can turn on the delayed detection function, and the vehicle will perform life detection after 8 minutes.
- Trailer Mode: Tap to manually turn the trailer mode on or off. When a trailer is detected, the trailer mode will be automatically turned on. To ensure driving safety, some of the advanced driver-assistance system (ADAS) functions will be disabled in this mode (this function takes effect after adding the trailer rear mounting).
- Front passenger airbag\*: Tap to select to turn on or off the front passenger airbag. After being turned off, the front passenger airbag will not deploy under any circumstances.
- Setting the operation password: Tap the Set Password button, enter the operation password, and complete the setting.
- Setting the maximum speed limit password: Tap the Set Password button, enter the password, and complete the setting.
- Owner Binding Authentication: Tap the Owner Authentication button and follow the instructions on the page to complete the binding authentication.

In the "System - Maintenance" interface, you can tap to set the following functions:

- Vehicle power supply: can be set to power off during maintenance and power on upon recovery.

- Electronic parking brake (EPB): Tap the EPB button, and the EPB will be applied.
- Reboot MMI: Tap the reboot button and follow the page prompts to complete the MMI reboot.
- Front wiper maintenance: Tap to turn the front wiper maintenance function on or off.

### WARNING

- Maintenance power down should only be used in emergencies and when maintenance of the high voltage is required. Tapping maintenance power down will cause the vehicle to immediately power down and enter repair mode, which may be a safety risk if triggered while driving.

### NOTE

- When the infotainment system experiences operational lag or functional errors, you can restart the infotainment system to restore it to the status it was in when the vehicle was started.
- The front wiper maintenance function is only supported for use when replacing the wiper blade or servicing the wiper.
- Front wiper maintenance failed to turn on, please try turning it back on when the vehicle is not started.

In the "System - General" interface, you can tap to set the following functions:

- Check the system software version and vehicle VIN.
- Automatically download system upgrade package\*: When enabled, it will automatically start downloading the upgrade package when connected to WIFI.
- App Management: Tap the Cache Clear button to clear the app cache.
- Language: Tap to select the system language.
- Time Zone: You can choose to set the time zone automatically or manually.
- Restore Factory Settings: Tap the restore button, enter the operation password, and complete the restore to factory settings.
- View Leapmotor IoV Privacy Policy\*.
- View open source license.
- View privacy permission management\*.

## APPLICATION CENTER

Tap the app icon  in the bottom bar of the infotainment screen to access the App Center interface. You can select the corresponding application and tap to enter.

### NOTE

- Due to different vehicle configurations, as well as your installation and uninstallation of applications, the actual vehicle application shall prevail.

## SPEECH RECOGNITION

The voice recognition function can be turned on in the following two ways:

- Press the voice button on the right side of the steering wheel  to turn on the voice recognition function.
- In the "Settings - Leapmotor Assistant" interface, tap the "voice activation" button to enable the voice activation function. Once the function is turned on, you can wake up the voice assistant by saying the wake-up word "Hi Leapmotor".

### NOTE

- After voice activation, the system will give a response. At this time, you can say the function or operation you want to achieve, such as: "open the low beam." The infotainment system recognizes this and turns on the low beam. Press the voice button on the right side of the steering wheel again to turn off the voice recognition function.

## OTA UPDATE

This vehicle is equipped with OTA upgrade function. OTA Update Steps:

1. Tap into the "Settings - System - General" interface. When the infotainment system detects an OTA upgrade package pushed by Leapmotor, the system will indicate that there is an update. After tapping Confirm, the system will pop up an upgrade prompt.
2. Read and agree to the information shown on the upgrade prompt screen, tap "Confirm", and wait for the installation. If you touch "Cancel", next time you can touch the system upgrade icon in the top bar of the infotainment screen to open the system update interface for installation and upgrade.
3. During the upgrade process, the infotainment screen and instrument cluster will restart several times, and window control, vehicle locking and unlocking, and other functions may be temporarily unavailable.
4. Once the upgrade is complete, the system will reboot, and the vehicle can be used again.

### NOTE

- Before upgrading, please make sure the vehicle is in Park (P), apply the parking brake, and make sure the vehicle's battery level is not less than 20%.
- Some functions may not work properly during the upgrade process.
- If the upgrade conditions are not met, the infotainment screen gives message feedback until the conditions are met to start upgrading the infotainment system.
- During the upgrade process, the vehicle cannot be driven, the upgrade screen is displayed on the infotainment screen and the instrument cluster, and no other operations can be performed.
- If the upgrade fails, some vehicle functions may experience abnormalities (unable to charge or the electronic parking brake (EPB) cannot be released, etc.). There will be corresponding fault prompts on the infotainment screen. If the vehicle cannot be driven or the vehicle power supply cannot be switched to the "READY" status, it is recommended to contact an authorized dealer to seek help.

## MAP UPDATE\*

When you need to perform a map update, follow the steps below:

1. Tap the navigation card or navigation App icon  on the home screen of infotainment screen to enter the map interface.

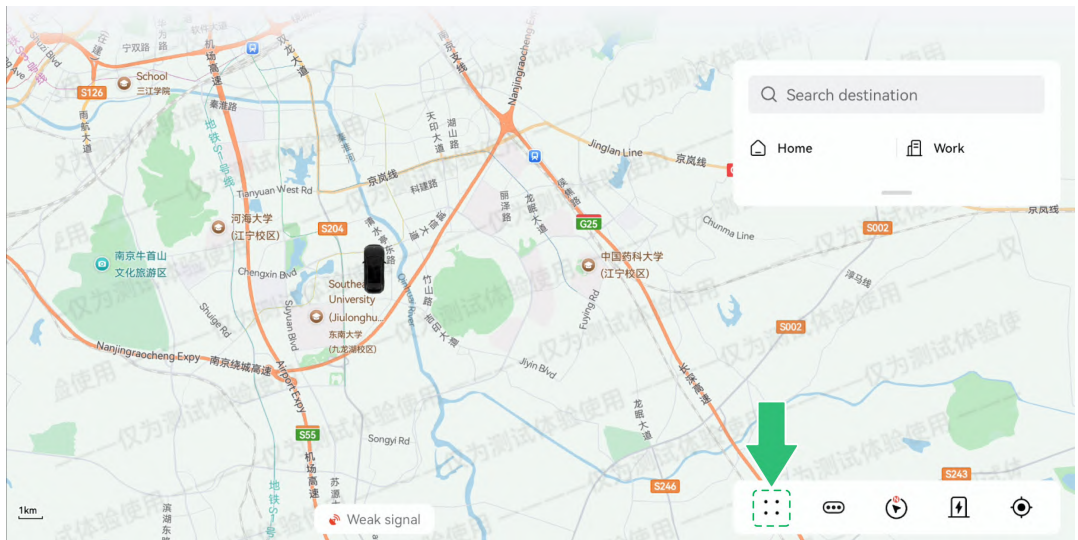

2. Tap the Settings button in the operation bar to enter the "Settings" interface.

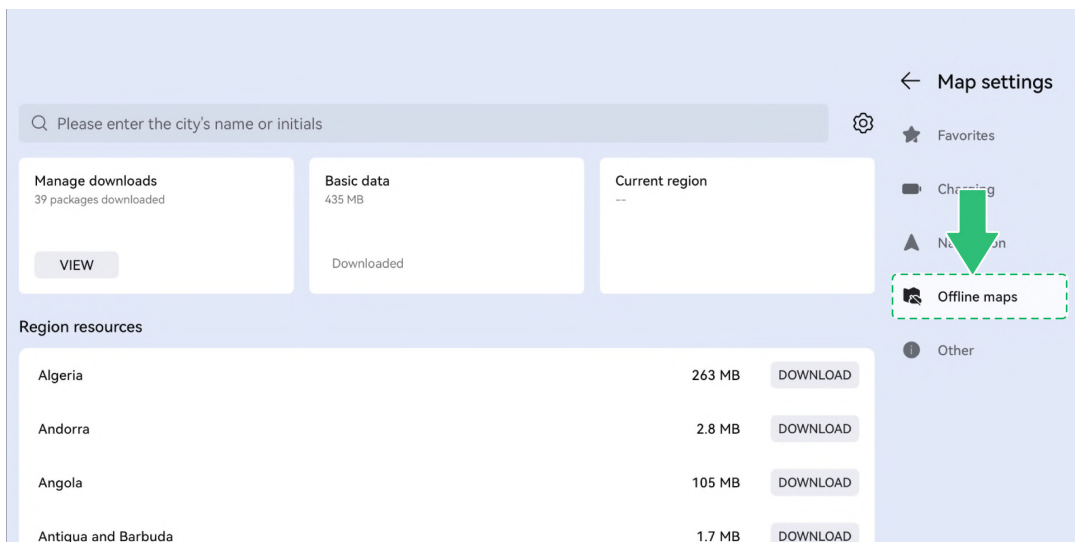

3. Offline Map: Tap "Offline Map" in the navigation bar to view the download status of the offline map list (downloadable/downloaded).

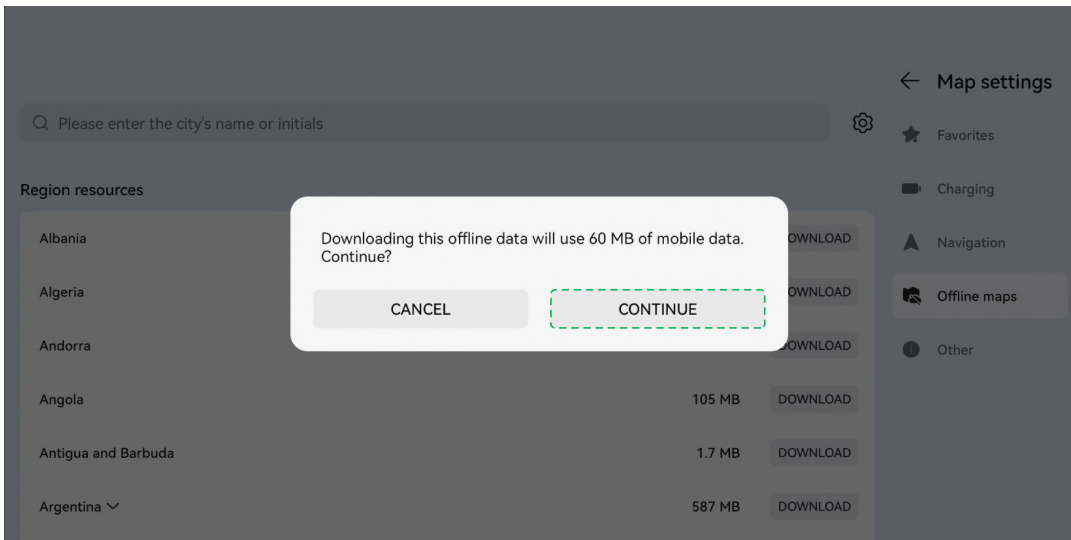

4. Regional resources: Supports searching and scrolling down to view offline map resources displayed at city or country level. After tapping "Download," a prompt will appear indicating data usage; download can proceed after confirmation.



5. Download Management: You can view the downloading and downloaded sections. Operations such as "Pause," "Resume Download," "Cancel Download," and "Delete" are supported. Tap the Download Progress button to pause download, and tap it again to resume download. Downloaded regional resources support deletion; tapping "Delete" in the pop-up window prompt can complete deletion.

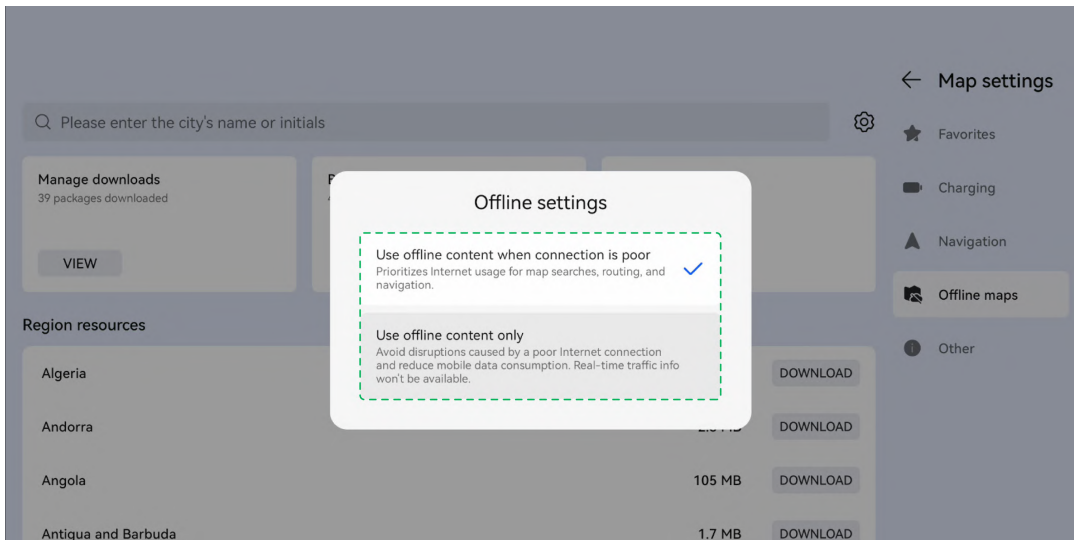

6. Offline Map Setting: Support switching between online map priority and offline map priority.

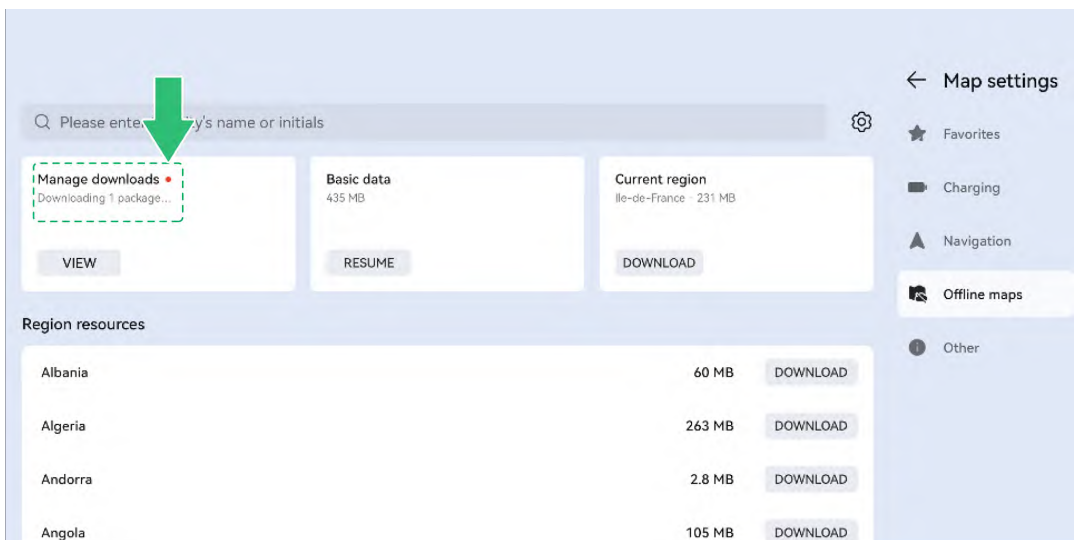

7. Resource Update: When there are regional resources available for update, a red dot will appear as a prompt.

#### NOTE

- If the update fails by following the above operation, it is recommended to contact the authorized dealer.

## CAR KEY

### NFC KEY

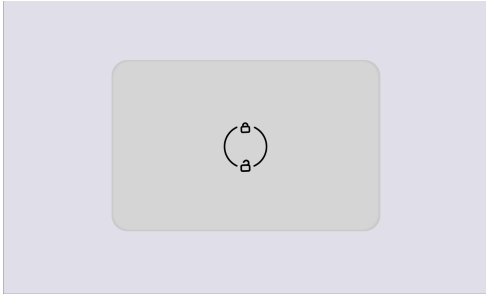

Unlocking: touch the NFC identification area of the driver side exterior rearview mirror for more than 1s for unlocking.

Locking: when all doors are closed and the vehicle is in P gear, touch the NFC identification area of the driver's exterior rearview mirror for more than 1s, and the vehicle is locked and powered off.

#### ⚠ WARNING

- Do not leave children or persons with disabilities alone in the vehicle, as they may be unable to leave the vehicle independently, potentially leading to accidents or life-threatening situations.
- If you are using any medical electrical devices, such as a pacemaker or implantable cardioverter defibrillator, please confirm with the manufacturer of the medical electrical device whether the NFC key affects the normal use of the implanted device before using the NFC key.

#### ⚠ ATTENTION

- Prevent the NFC key from coming into contact with liquid, otherwise it may damage the NFC key.
- Do not place the NFC key together with or too close to the devices that can generate magnetic field (mobile phone, stereo, etc.), otherwise the function of the NFC key may fail.
- When you leave the vehicle, be sure to take the NFC key with you, otherwise you may not be able to lock the vehicle.

- The NFC key is an electronic component; please avoid impact, disassembly, or placing it in high temperature, humidity, or strong vibration environments.
- If the NFC key is lost or damaged, it is recommended to contact an authorized dealer immediately to avoid vehicle theft or accidents.
- Do not put the NFC key in the trunk, as it may be accidentally locked inside the car.
- Do not leave the NFC key in a hot place, such as on an instrument panel exposed to the summer sun.
- Do not bend the NFC key forcefully.
- Do not place the NFC key in the charging area while wireless charging is on.
- Do not immerse the NFC key in water or wash it in an ultrasonic washer.
- Do not place the NFC key together with devices that emit electromagnetic waves, such as mobile phones.
- Do not attach any objects (such as metal seals) that could block electromagnetic waves to the NFC key.
- Spare keys can be registered for the same vehicle. For detailed instructions, it is recommended that you contact an authorized dealer.
- NFC key is near-field communication, and recognition requires full contact.
- The recognition distance of the NFC key is within 1~2cm, and the recognition time may take 1~2s.
- Do not place the NFC key near or in contact with metal or magnetic materials.
- Do not attach anything to the surface of the NFC key.
- Do not attach a protective sleeve (e.g. metal sleeve) that may interfere with the signal.

#### 📌 NOTE

- The driver shall make sure the vehicle is locked before leaving.

## MECHANICAL KEY



If the NFC key does not work, the driver's side door can be unlocked/locked using the mechanical key, but the vehicle cannot be started.

### NOTE

- The mechanical key is provided separately along with the vehicle. Please store it separately and keep it properly to avoid loss.

## BLUETOOTH KEY

The Bluetooth key is integrated into the Leapmotor App and can be used for close-range unlocking and locking of the vehicle when there is a network anomaly or the App cannot be used for remote unlocking and locking\*.

A Bluetooth connection is established between the phone and the vehicle, and authentication is completed to be recognized as a legitimate key:

1. Turn on the phone's Bluetooth.
2. Set the Leapmotor App location permission to Always Allow.
3. Log in to Leapmotor App.
4. Select the current vehicle in the My Vehicles interface.
5. Touch the Bluetooth key icon in the "Car" interface to enter the setting interface to turn on the function.

## BLUETOOTH KEY FUNCTION

No.	Functions
1	Auto unlocking when near the vehicle
2	Stay away from vehicle automatic locking

No.	Functions
3	Bluetooth disconnect auto-lock
4	The unlocking and locking of the main driver seat door handle button
5	Self-service troubleshooting function
6	OTA remote upgrade

### NOTE

- To use the Bluetooth key, please first turn on your cell phone Bluetooth and MMI Bluetooth, and enable your cell phone location information.
- Within the effective range of the vehicle, you can use the Bluetooth key in the Leapmotor App to operate the above functions, and this operation can also be performed normally without relying on the network.
- To ensure the Bluetooth key functions properly and to have a better Bluetooth experience, please update the Leapmotor App on your phone in a timely manner.

## DOOR

### DOOR UNLOCKING/LOCKING WITH NFC KEY



Hold (for at least 1 second) a valid NFC key against the card reader area (located on the driver-side exterior rearview mirror). After the vehicle detects the NFC key, the unlock/lock function can be realized.

### NOTE

- The auto-folding/unfolding function for exterior rearview mirrors\* can be configured via the Infotainment Screen.

## BLUETOOTH KEY UNLOCKING/LOCKING DOOR

After establishing an effective connection between the phone Bluetooth and the vehicle Bluetooth, carrying the phone Bluetooth key can realize the keyless entry function.

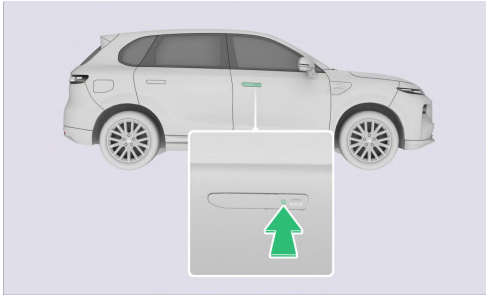

When the vehicle is in a locked status, press the button on the door handle of the driver seat to unlock the vehicle.

When the vehicle is in an unlocked status, stationary, and all doors are closed, if there is no one in the driver seat at this time, pressing the driver seat door handle button will lock the vehicle and cut off the power.

Press and hold the door handle button for more than 20s to reset the Bluetooth key. (If the Bluetooth key is displayed as unavailable or the Bluetooth key is not detected when using the Bluetooth key to control the vehicle, try this operation to solve the fault.)

### NOTE

- When connecting the Bluetooth key, you need to turn on the Bluetooth function of your cell phone and enable the location information on your cell phone.

## STEERING WHEEL BUTTON TO UNLOCK/LOCK DOOR

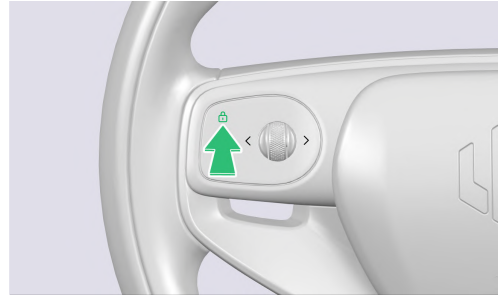

When all doors are closed, press the whole vehicle unlock/lock button on the steering wheel to unlock/lock all doors.

## INFOTAINMENT SCREEN BUTTON TO UNLOCK/LOCK DOOR

When all doors are closed, tap the "Lock" hotspot icon on the infotainment screen home page or the lock icon in the top bar\*  to unlock or lock all doors.

## DOOR UNLOCKING/LOCKING WITH MECHANICAL KEY

When the doors cannot be unlocked/locked using the NFC key/Bluetooth key, you can use the mechanical key to unlock/lock the doors.

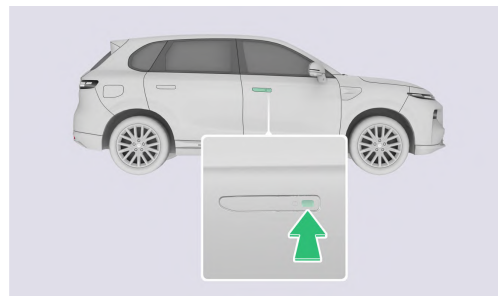

1. Manually press the front end of the driver's side door handle and extend the handle until the mechanical lock cylinder is exposed.

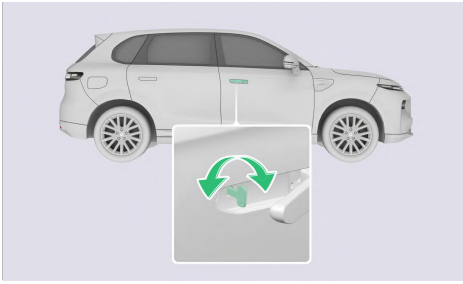

2. Insert the mechanical key into the lock cylinder.
  - Turn the key counterclockwise to unlock the driver's side door.
  - Turn the key clockwise to lock the driver's side door.

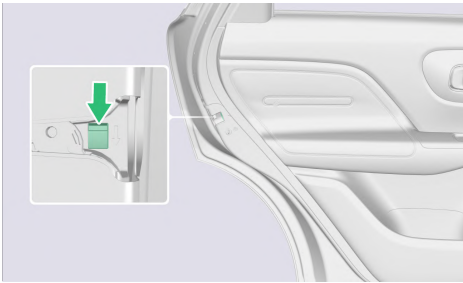

3. To lock the remaining doors, you can push the block inside the door lock down. After closing the door, it will be locked.

#### ⚠ ATTENTION

- When opening the door with the mechanical key in extremely cold weather, if the key cannot be returned, please do not forcibly take out the key, and contact the authorized dealer.

## OPEN THE DOOR OUTSIDE THE VEHICLE

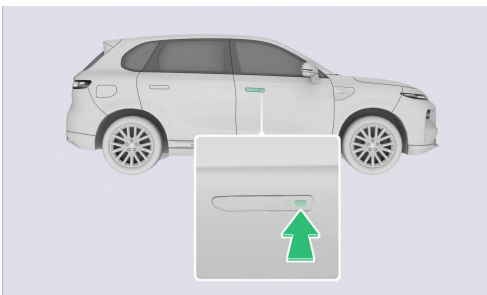

When unlocking the vehicle, press the recessed area of the door handle with your finger to lift the rear end of the door handle and pull it to open the door. When released, the door handle will automatically retract.

#### ⚠ ATTENTION

- When the temperature is below 0 °C, do not use a high-pressure water gun to directly rinse the door handle during car washing; you can use a wet rag or other cleaning tools to gently wipe it.

#### 🔑 NOTE

- If a door handle is frozen with snow or ice, you can de-ice it by pressing the rear end of the door handle several times in a forceful reciprocal motion. If the ice layer is thick, a tool is needed to break the ice layer and assist in opening the door.

## INSIDE DOOR OPENING HANDLE



When the vehicle is locked, pull up the inside door opening handle toward the inside of the vehicle to unlock the corresponding side door. Pull up the inside door opening handle again to open the door.

#### ⚠ WARNING

- Do not pull the interior door handle while driving.

#### ⚠ ATTENTION

- When the child safety lock is turned on, it will not be possible to open the rear door from

inside the vehicle; in this case, the door should be unlocked to open it from outside the vehicle. Do not pull too hard on the interior handle of the door to avoid damage.

## CHILD SAFETY LOCK

The rear doors of the vehicle are equipped with a child safety lock to prevent children from opening the door from inside the vehicle.

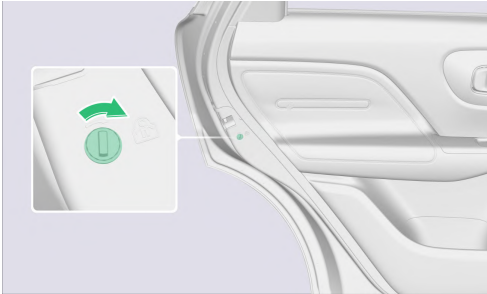

Insert the mechanical key into the child safety lock and rotate it in the direction shown in the picture. At this time, the door can only be opened from the outside and cannot be opened from the inside.

### ⚠ ATTENTION

- When the child lock is activated, do not leave children alone in the vehicle to avoid accidental injuries.
- When the child safety lock is activated, the status must be confirmed to prevent activation failure.

### 🔑 NOTE

- Please turn on the child safety lock when there are children in the vehicle.
- When the child safety lock is activated, the inner handles on the rear doors are disabled. At this time, the rear doors can only be opened from outside the vehicle.
- The illustration shows only the left rear door as an example; the child safety lock on the right rear door opens in the opposite direction.
- The child safety locks on the left and right rear doors must be activated separately.

## DOOR NOT CLOSED REMINDER

When the door is not closed, the door not closed indicator light  in the instrument cluster illuminates.

## COLLISION AUTO UNLOCKING

When the vehicle is involved in a collision incident, the door will automatically unlock and the hazard warning lamp will turn on automatically.

### 🔑 NOTE

- Whether the doors unlock automatically when the vehicle suffers a strong impact depends on the specific force of the impact and the type of incident.

## AUTO LOCKING WHEN DRIVING

When the vehicle speed is greater than 15km/h (9mile/h), the door is automatically locked.

## ELECTRIC LIFTGATE\*

### OPEN/CLOSE THE LIFTGATE

#### EXTERIOR SWITCH FOR OPENING THE LIFTGATE

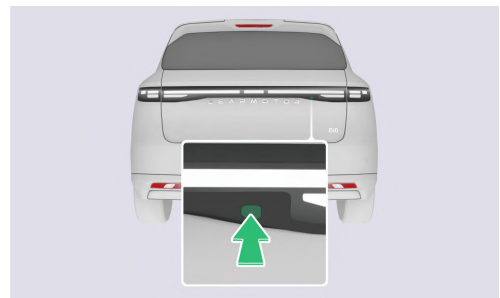

When the vehicle is unlocked and in a stationary status, if the power liftgate is closed, press the exterior switch of the liftgate and the power liftgate will automatically open to the set height.

During the opening process of the power liftgate, if you press the exterior switch of the liftgate, the liftgate will pause its operation.

## INTERIOR SWITCH FOR CLOSING THE LIFTGATE

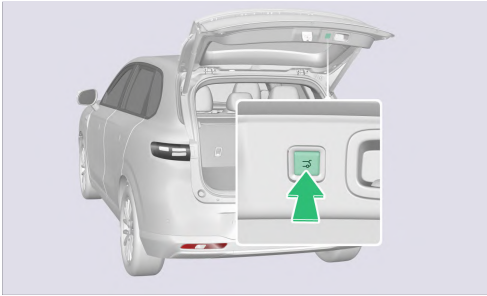

When the vehicle is in a stationary status, if the power liftgate is opened, press the interior switch of the liftgate, and the power liftgate will automatically close.

During the closing process of the power liftgate, if you press the interior switch of the liftgate, the liftgate will pause its operation.

## OPEN/CLOSE THE LIFTGATE VIA THE INFOTAINMENT SCREEN

In the interface of "Settings - Doors & Windows" on the infotainment screen, touch the liftgate button on the infotainment screen to open/close/pause the liftgate; touch the "Liftgate Height" button on the infotainment screen to enter the liftgate height adjustment interface; slide the slider up/down to set the opening height of the liftgate.

### ⚠ WARNING

- It is strictly prohibited to drive the vehicle with the power liftgate in the open status.
- Do not open the trunk when there is a large load (e.g., snow, ice, etc.) on the liftgate to avoid vehicle damage or safety incidents.
- When opening/closing the motorized liftgate, please check the surrounding environment and take care to avoid people or obstacles within the range of movement of the liftgate to avoid incidents.
- Do not operate the liftgate while the vehicle is in motion.
- Do not let anyone ride in the trunk.
- Do not allow children to play in the trunk under any circumstances.
- When opening/closing the liftgate in weather with strong winds, the liftgate may move suddenly due to strong winds.

- When storing liquid items, care should be taken to keep them sealed to prevent liquid leakage from causing damage to the vehicle. If leakage occurs, please clean it up promptly.
- If the item is not secured or adequately secured, it may slide, tip over, or be thrown up, striking the vehicle's driver and passengers, especially when braking or making sudden turns, which may present a risk of injury.
- Do not drive the vehicle with the liftgate not properly latched to avoid sudden opening of the liftgate, which could result in falling objects or incidents.
- When closing the liftgate manually, special care should be taken to avoid getting pinched.

### ⚠ ATTENTION

- Do not install any accessories on the liftgate to avoid liftgate fault.
- Be careful when opening the liftgate in strong wind conditions. Under the action of strong winds, the liftgate may be opened too far, causing the liftgate to deform.
- If the liftgate is frozen or covered with snow or ice, do not force the liftgate open. Turn on the warm air and wait for the interior temperature to rise before opening the liftgate. In case of emergency, when the liftgate must be opened immediately, pour warm water to melt the ice and snow, and then open the liftgate after the icy position is loosened.
- Please load items reasonably according to the trunk space. If the load is too full, please do not forcefully press to close the liftgate, otherwise it may cause damage to the luggage or deformation of the liftgate.
- If the power liftgate is in the open status or during operation and the vehicle experiences a power cutoff, the liftgate power function is disabled. When the vehicle is powered up again, you need to manually close the liftgate once to activate the liftgate power function.

## EMERGENCY OPENING OF POWER LIFTGATE

When the power liftgate fails to open normally, it can be opened from inside the vehicle as an emergency measure.

1. Flick the backrest locking switch of the rear seat and flip the backrest of the rear seat forward to enter the trunk area.

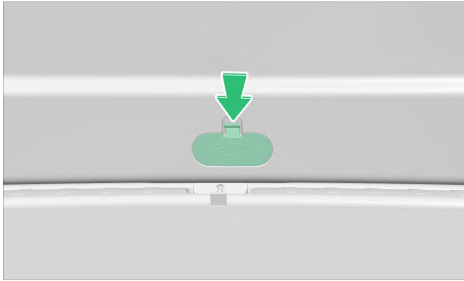

2. Remove the emergency switch trim cover on the liftgate.

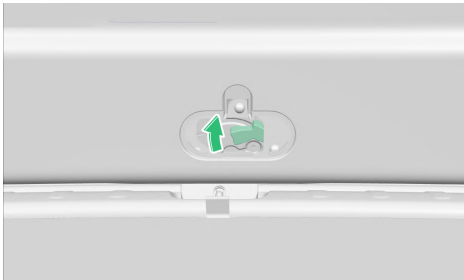

3. Turn the liftgate lock emergency switch clockwise to unlock the liftgate, and push the liftgate outward.

## ANTI-PINCH FUNCTION OF LIFTGATE

When the electric liftgate detects obstacles during operation, the anti-pinch function will be triggered. The liftgate pauses and operates in reverse for a certain distance, while the buzzer sounds for 4 times.

### **▲ WARNING**

- The anti-pinch feature may not work just before the liftgate is completely closed.

## LIFTGATE\*

### OPEN/CLOSE THE LIFTGATE

#### OPEN THE LIFTGATE

For the manual opening of the liftgate, refer to the section on the power liftgate. After unlocking the liftgate, you need to manually lift the liftgate up to a suitable position.

#### CLOSE THE LIFTGATE

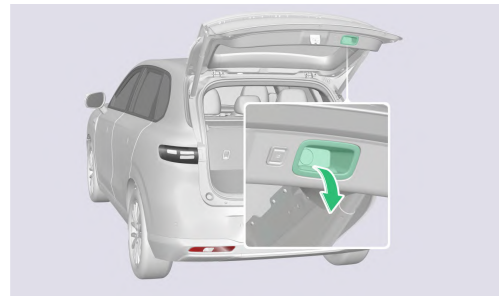

Lower the liftgate inner closing handle down close to the rear bumper, then press it down slightly to close it.

## EMERGENCY UNLOCKING OF MANUAL LIFTGATE

When the manual liftgate cannot be opened normally, it can be opened from inside the vehicle as an emergency measure.

1. Flick the backrest locking switch of the rear seat and flip the backrest of the rear seat forward to enter the trunk area.

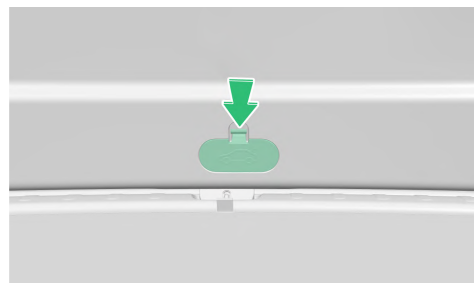

2. Remove the emergency switch trim cover on the liftgate.

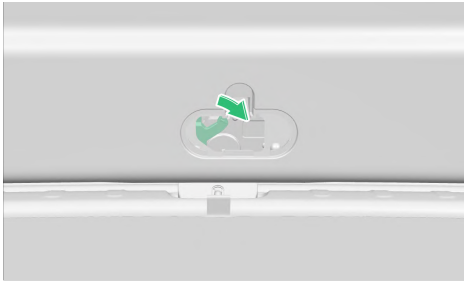

- Turn the liftgate lock emergency switch clockwise to unlock the liftgate, and push the liftgate outward.

## ELECTRIC WINDOW

### DRIVER SIDE WINDOW CONTROL

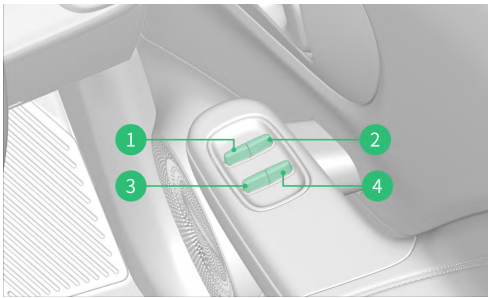

- Left front electric window control button
- Right front electric window control button
- Left rear electric window control button
- Right rear electric window control button

### MANUAL WINDOW LIFT

Press and hold the corresponding window control button backward for a long time to raise the corresponding side window. Release the button, and the window stops rising.

### AUTOMATIC WINDOW LIFT

Briefly pull the corresponding window control button backward, the corresponding side window rises; release the button, and the window rises to the fully closed position.

### MANUAL WINDOW LOWERING

Push forward and hold the corresponding window control button to lower the corresponding side

window. Release the button, and the window stops descending.

### AUTOMATIC WINDOW LOWERING

Short press the corresponding window control button forward, the corresponding side window lowers; release the button, and the window lowers to the fully open position.

## CONTROLLING VEHICLE WINDOWS VIA THE INFOTAINMENT SCREEN

The windows can be set in the "Settings – Doors & Windows" screen of the infotainment screen.

- Set the current window position to fully closed, fully open, or ventilated.
- Set the window lock function on or off. When the window lock function is on, the front passenger and rear seat occupants cannot operate the corresponding windows.
- Set to perform hold current, window close, or ventilation operation when the vehicle is locked.

### ⚠ WARNING

- It is the driver's responsibility to instruct other passengers on how to use the electric windows to ensure safety.
- Do not let children operate the windows to avoid getting pinched.
- When closing the windows, please ensure that the heads, hands, and other parts of all drivers and occupants are kept away from the windows to avoid accidental injury.

### 🔑 NOTE

- Refer to the driver's side window button for the operation of other window buttons.
- Please check that the vehicle windows are fully closed before leaving.
- When a single window is raised and lowered several times in a row, the window may enter the protection status, at which time it will not be possible to operate the window to raise and lower it, and the window will return to normal after 2min.
- The windows must be initialized before the automatic rising and lowering function is available. If the windows cannot be

automatically raised and lowered, re-initialization is required.

## CAR WINDOW ANTI-PINCH FUNCTION

The vehicle has anti-pinch features on all four doors' windows. During the automatic rising of the window, if an obstacle is detected that hinders the window's operation, the window will reverse its movement for a certain distance and then stop.

### ▲ WARNING

- Light or small items cannot interrupt the operation of the window, and the anti-pinch feature may not work.
- It is strictly prohibited to use any part of the body to test the anti-pinch function.
- Despite the anti-pinch protection, it is still necessary to ensure that the window closing area is unobstructed, but under special circumstances (e.g. thin or soft obstacles) the anti-pinch function cannot be guaranteed to activate.
- When driving in special road conditions, closing the windows may trigger the anti-pinch feature.
- Do not operate when there is an obstacle in the window area to avoid pinching or damaging the window.

## INITIALIZE WINDOW

Manually lower the window to the lower stop, then raise the window to the upper stop and hold it for more than 1 second. After the motor stops working, release the button to complete the window initialization.

## ELECTRIC SUNSHADE

### SUNSHADE CONTROL

In the interface of "Settings-Window & Door-Sunshade" on the infotainment screen, you can slide up and down in the sunshade area to control the sunshade opening to the corresponding proportion.

### ▲ WARNING

- Do not operate when there is an obstacle in the sunshade area to avoid pinching or damaging the sunshade.
- Do not let children operate the sunshade to avoid getting pinched.
- When closing the sunshade, take care to avoid an occupant's body part being caught in the closing sunshade, which could result in serious injury.

### 🔑 NOTE

- When the sunshade runs for more than 120 seconds, the motor heat protection function is activated and the sunshade will stop moving.

## SUNSHADE ANTI-PINCH FUNCTION

When the sunshade encounters an obstacle during closing, the sunshade will slide backward to a certain position.

### ▲ WARNING

- The sunshade anti-pinch function cannot pinch thin or small items.
- It is strictly prohibited to use any part of the body to test the anti-pinch function.
- When closing the sunshade, please ensure that all occupants keep their heads, hands, and other body parts away from the sunshade. Avoid causing accidental injuries to drivers and occupants.

## SUNSHADE INITIALIZATION

If the sunshade cannot close normally or does not close tightly after a period of use, it is necessary to initialize the sunshade:

1. In the interface of "Setting-Window & Door" on the infotainment screen, long press the sunshade button for 10 seconds, the sunshade will start to run (the sunshade can be released when it starts to run), the sunshade will run to the fully open position, and then run to the fully closed position again. After recording the fully closed position, the sunshade will run to the

fully open position again and stop. Initialization ends.

2. The infotainment screen will prompt whether the sunshade initialization is successful or failed. If it prompts that the sunshade initialization failed, please repeat the above steps and operate again.

#### **⚠ WARNING**

- During the initialization operation of the sunshade, take care to avoid an occupant's body part being caught in the closing sunshade, which could result in serious injury.

#### **🔑 NOTE**

- During the initialization operation of the sunshade, clicking the sunshade button again to stop the sunshade operation will cause the initialization to fail and require reoperation.
- During the initialization operation of the sunshade, vehicle power disconnection will cause the initialization to fail and require reoperation.

## BONNET

### HOOD OPENING

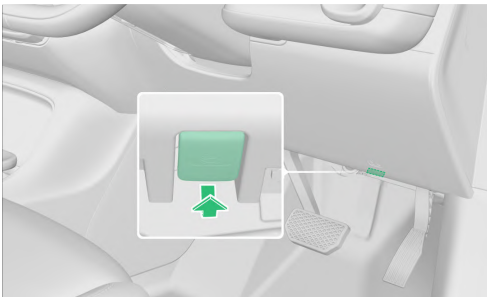

1. Pull the release handle of the bonnet twice in succession, and the bonnet will unlock and pop up slightly.

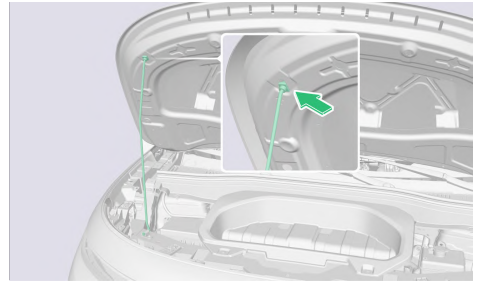

2. Lift the front hood upwards and support it with the supporting rod.

#### **⚠ WARNING**

- Do not open the hood while the vehicle is in motion.

#### **⚠ ATTENTION**

- To avoid scratches, do not carry any items in your hands (e.g. car keys, jewelry, etc.).
- When opening the bonnet in snowy or icy conditions in winter, clear the snow (or ice) from the hood before opening.

### HOOD CLOSED



Before closing the hood, check that no tools, waste cloths, etc. are left in the front compartment, stow the stay bar, then slowly lower the hood to a certain height, then release the bonnet to allow it to drop freely and ensure that it is locked in place. If necessary, press down on the front edge of the hood to lock it in place.

If the hood is not fully closed, reopen the hood, and then close it properly.

**▲ WARNING**

- Before driving, make sure that the hood is closed and locked, otherwise the hood may suddenly open while driving, resulting in an incident.
- Before closing the hood, ensure that the closing path under the hood is not obstructed, otherwise there is a risk of personal injury.

**🔑 NOTE**

- Do not press hard on the hood to avoid causing damage to the hood.

## EXTERIOR MIRRORS

### EXTERIOR REARVIEW MIRROR POWER ADJUSTMENT

1. In the "Settings - Driving" interface of the infotainment screen, touch the "Rearview Mirror Adjustment" button to enter the rearview mirror adjustment interface.

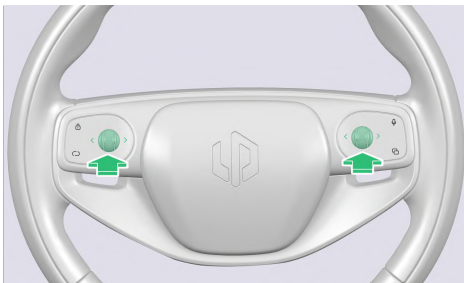

2. Scroll the left/right wheel on the steering wheel up and down to adjust the angle of the left/right exterior rearview mirrors up and down. Toggle the left/right wheel on the left/right side of the steering wheel to adjust the angle of the left/right exterior rearview mirror.

**▲ WARNING**

- It is strictly prohibited to adjust the exterior rearview mirrors during driving to prevent incidents due to distraction.

### OUTSIDE REAR-VIEW MIRROR HEATING

When driving on rainy days, the exterior rearview mirrors are prone to residual water droplets, causing the driver's field of vision to be obstructed, affecting driving safety. The exterior rearview mirror heating function keeps the exterior rearview mirrors clear by heating the rearview mirror glass so that water droplets on the glass are heated and evaporated.

In the "Settings - Driving - Rearview Mirror Adjustment" interface of the infotainment screen, touch the "Heating" button to turn on or off the heating function of the exterior rearview mirrors.

**▲ WARNING**

- Do not touch the exterior rearview mirror glass with your hands during the heating of the rearview mirrors to avoid burns.

### ELECTRIC FOLDING OF THE EXTERIOR REARVIEW MIRROR

When the exterior rearview mirrors are in the unfolded status, in the "Settings-Driving-Rearview Mirror Adjustment" interface of the infotainment screen, touch the "Fold" button to electrically fold the exterior rearview mirrors. When the exterior rearview mirrors are in the folded status, touch the "Expand" button to electrically expand the exterior rearview mirrors.

### EXTERIOR REARVIEW MIRRORS AUTO-FOLD WHEN LOCKING\*

After enabling the function of automatic folding/expanding of exterior rearview mirrors in the interface of "Settings-Driving-Rearview Mirror Adjustment" on the infotainment screen, the exterior rearview mirrors will be automatically expanded when the vehicle is unlocked, and automatically folded when the vehicle is locked.

## MANUAL FOLDING OF THE EXTERIOR REARVIEW MIRROR

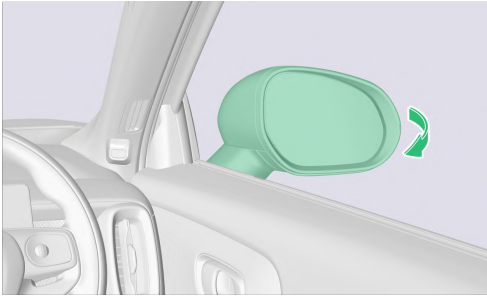

Push the exterior rearview mirror toward the rear of the vehicle to fold the exterior rearview mirror.

### ⚠ ATTENTION

- Do not fold the exterior rearview mirrors with power folding function manually too often, otherwise the internal folding mechanism will be damaged prematurely, resulting in power folding failure.

## INSIDE REAR-VIEW MIRROR

### INTERIOR REARVIEW MIRROR ADJUSTMENT

Adjust the interior rearview mirror to the proper angle before driving the vehicle.

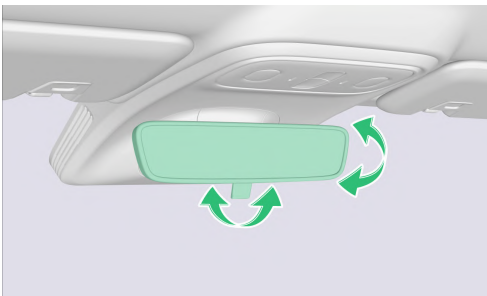

Turn the interior rearview mirror up and down, left and right to adjust it to the proper rearview position.

## MANUAL ANTI-GLARE

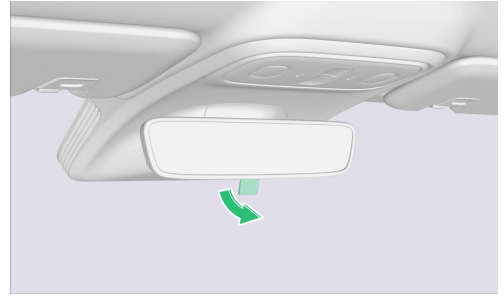

When the vehicle lamps of a car behind are too strong, flip the handle at the lower end of the interior rearview mirror to tilt the mirror at an angle to prevent driver glare.

### ⚠ WARNING

- Do not adjust the interior rearview mirror during driving to avoid distraction that could result in loss of vehicle control and danger.
- When adjusting the interior rearview mirror, please do not adjust it violently if it is stuck, as it may cause the interior rearview mirror to fall off.
- Do not install any objects around the interior rearview mirror to avoid interfering with the driver's ability to observe the road.
- Do not hang heavy objects from the interior rearview mirror or rock or drag it with force.

## STEERING WHEEL

### STEERING WHEEL BUTTON INFORMATION

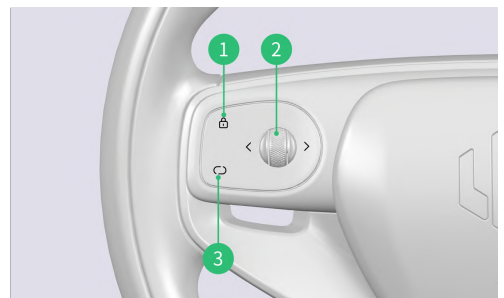

1. Unlocking/Locking button

- Press the button to unlock/lock the vehicle. (This operation is invalid when the vehicle is in the anti-theft state.)
2. Left scroll wheel
    - Cruise scenario: Each upward scroll increases the cruise speed by 1 km/h; each downward scroll decreases the cruise speed by 1 km/h; when ACC and LCC are activated and the dashboard displays a speed limit reminder, press down to confirm and control the vehicle speed; scroll left to decrease the following distance; scroll right to increase the following distance.
    - Exterior rearview mirror adjustment scenario: Scroll up or down to vertically adjust the left exterior rearview mirror; push left or right to horizontally adjust the left exterior rearview mirror.
  3. Custom button
    - Press the button (once or twice) to activate custom functions.
    - Custom functions can be set through the "Settings - Driving - Steering Wheel Custom Button" interface on the Infotainment Screen.

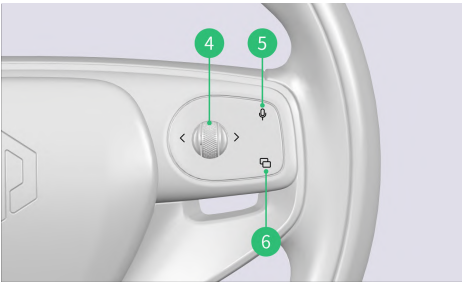

4. Right scroll wheel
  - Media playback scenario: Scroll up to increase the volume, scroll down to decrease the volume; press the roller to play/pause multimedia. Slide left: last song; toggle right: next song.
  - Bluetooth phone scenario: When a call comes in, toggle left to answer the phone, toggle right to hang up the phone.
  - Exterior rearview mirror adjustment scenario: Scroll up or down to vertically adjust the right exterior rearview mirror; push left or right to horizontally adjust the right exterior mirror.
  - Navigation scenario\*: Scroll up to select the previous navigation route, and scroll down to select the next navigation route.

5. Voice button
  - Press the button to turn on the voice recognition function.
6. Instrument information switching button
  - Press the button to cycle through the information displayed on the right side of the dashboard.

## HORN

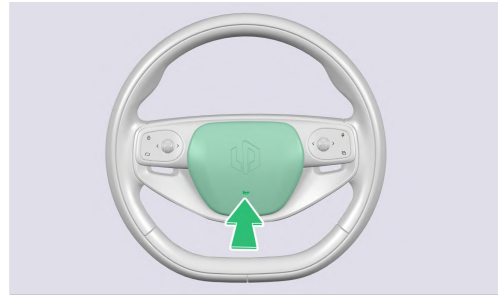

Press the center area of the steering wheel to sound the horn, release to stop sounding.

### NOTE

- Please do not use the horn arbitrarily in non-honking areas (government offices, schools, military units, hospitals, residential communities, etc.) to reduce noise disturbance.
- When using the horn, please comply with local traffic regulations.

## ADJUST THE STEERING WHEEL

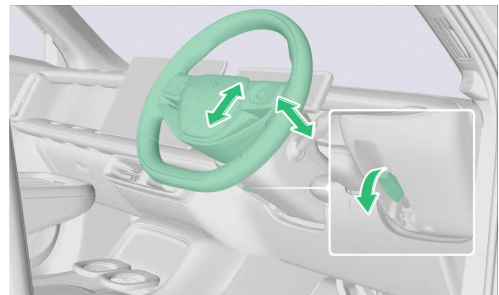

Before driving the vehicle, please adjust the steering wheel position according to your needs.

1. Push the steering wheel adjustment handle downward.
2. Hold the steering wheel firmly with both hands, and adjust the steering wheel up and down, back and forth until the desired position is reached.
3. Turn the steering wheel adjustment handle upward and lock the steering wheel.
4. Move the steering wheel up, down, forward, and backward, and confirm that the steering wheel is securely locked.

### ⚠ WARNING

- Do not adjust the steering wheel while the vehicle is in motion to avoid causing a traffic incident.
- Make sure the steering wheel is locked securely after adjusting the steering wheel. Otherwise the steering wheel may move suddenly, causing an incident that could result in serious injury or death.
- Improperly adjusted steering wheel position or improper seating position can cause personal injury. For safety, the steering wheel should be directly in front of the chest, and it is recommended that the distance between the steering wheel and the chest is not less than 25cm; otherwise, the airbag cannot provide effective protection in the event of an incident.

## STEERING WHEEL HEATING\*

The steering wheel heating feature makes the steering wheel warm during the cold season.

On the 'Seat' interface/screen of the central control screen, the steering wheel heating function can be turned on or off. Touch the "Settings" button on the seat interface to turn on or off the automatic steering wheel heating function. When the function is turned on, the system automatically turns on the steering wheel heating when the temperature is low.

### ⚠ ATTENTION

- After the steering wheel heating function is turned on, if you don't feel any change in temperature or hotness for a long time, you should turn off this function immediately and

promptly go to an authorized dealer to have it checked and repaired.

## SEATS

### FRONT DRIVER SEAT

#### 6-WAY ELECTRIC ADJUSTMENT

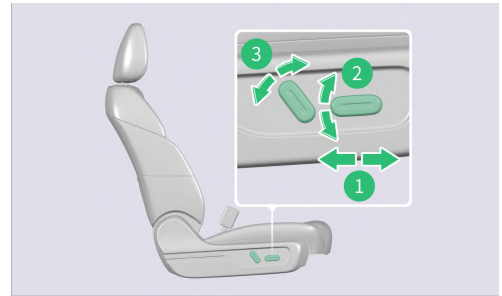

Push the seatback angle adjustment switch forward or backward in the direction indicated by arrow ①, and the seat will slide forward or backward. Release the adjustment switch, and the seat stops sliding.

Move the seatback angle adjustment switch up or down in the direction indicated by arrow ②, and the seat will rise or fall. Release the adjustment switch, and the seat stops lifting.

Push the seatback angle adjustment switch forward or backward in the direction indicated by the ③ arrows, and the backrest will tilt forward or backward. Release the adjustment switch, and the backrest stops tilting.

#### 6-WAY MANUAL ADJUSTMENT\*

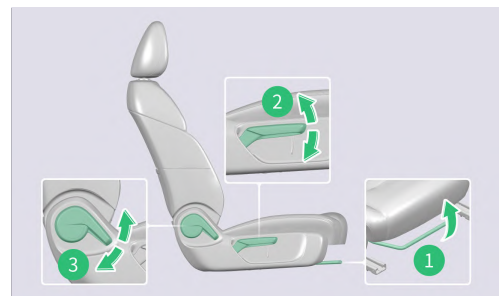

Pull the unlocking lever upward in the direction shown by arrow ①, then lean your body lightly against the seat and slide the seat forward or backward. Release the unlocking lever, the seat

stops sliding, apply slight force forward or backward with your body, you will hear a "click" sound, and the seat is locked.

In the direction shown by arrow ②, repeatedly pull up or press down the adjustment handle, the seat will be raised or lowered; release the adjustment handle, and the seat will stop raising or lowering.

Pull up the unlocking handle upward in the direction shown by arrow ③, and use the pressure on your back to control the backrest to tilt forward or backward, adjust the backrest to the desired position, and release the adjustment handle.

**⚠ WARNING**

- Be sure to use caution when adjusting the seat to ensure that the seat movement does not injure other occupants.
- Do not place your fingers or other parts of your body under the seat, otherwise they may be caught in the seat.
- Do not adjust the seat while driving to avoid losing control of the vehicle due to seat movement.
- Do not adjust the seat while the seat belt is fastened to avoid incidents where the seat belt cannot maintain its normal status, causing injury to occupants and failure of the protection function.
- It is strictly prohibited to add seat covers to the seats, to avoid the side airbag failing to deploy properly when an incident occurs.

**🔑 NOTE**

- Do not place any objects under the seat, otherwise it may obstruct the operation of the seat.
- After adjusting the seat, push the seat and seat backrest forward and backward to confirm that the seat and seat backrest are locked.
- Remove the headrest from the driver seat, adjust the seat position to the front, keep the height at the designed position (20mm above the lowest position), and adjust the backrest angle to the rearmost position. The driver seat can then be leveled with the rear seat cushion to form a "large bed" mode for the driver to rest.

## FRONT ROW FRONT PASSENGER SEAT

### 4-WAY ELECTRIC ADJUSTMENT

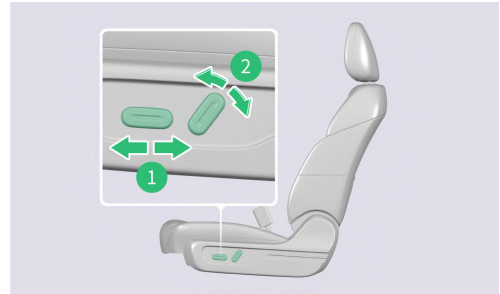

Push the seatback angle adjustment switch forward or backward in the direction indicated by arrow ①, and the seat will slide forward or backward. Release the adjustment switch, and the seat stops sliding.

Push the seatback angle adjustment switch forward or backward in the direction indicated by the ② arrows, and the backrest will tilt forward or backward. Release the adjustment switch, and the backrest stops tilting.

### 4-WAY MANUAL ADJUSTMENT\*

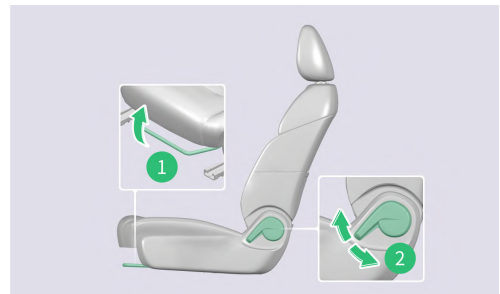

Pull the unlocking lever upward in the direction shown by arrow ①, then lean your body lightly against the seat and slide the seat forward or backward. Release the unlocking lever, the seat stops sliding, apply slight force forward or backward with your body, you will hear a "click" sound, and the seat is locked.

Pull up the unlocking handle upward in the direction shown by arrow ②, and use the pressure on your back to control the backrest to tilt forward or backward, adjust the backrest to the desired position, and release the adjustment handle.

**▲ WARNING**

- Be sure to use caution when adjusting the seat to ensure that the seat movement does not injure other occupants.
- Do not place your fingers or other parts of your body under the seat, otherwise they may be caught in the seat.
- When adjusting the seat backrest tilt angle, make sure that your back is pressed against the seat backrest to prevent the seat backrest angle from folding too quickly, which may cause unnecessary injury.
- Do not adjust the seat while driving to avoid losing control of the vehicle due to seat movement.
- Do not adjust the seat while the seat belt is fastened to avoid the seat belt coming off, causing injury to occupants and failure of the protection function.
- It is strictly prohibited to add seat covers to the seats, to avoid the side airbag failing to deploy properly when an incident occurs.

**🔑 NOTE**

- Do not place any objects under the seat, otherwise it may obstruct the operation of the seat.
- After adjusting the seat, push the seat and seat backrest forward and backward to confirm that the seat and seat backrest are locked.
- Remove the headrest from the front passenger seat, adjust the seat position to the front and adjust the backrest angle to the rearmost position. The front passenger seat can then be leveled with the rear seat cushion to form a "large bed" mode for the occupant to rest.

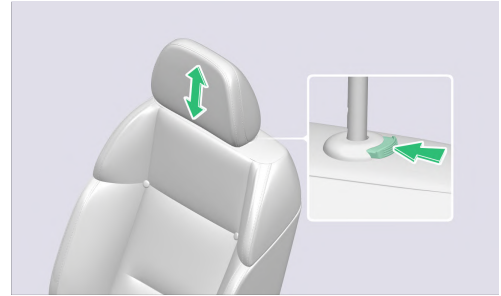
**FRONT HEADREST HEIGHT ADJUSTMENT**

**Elevation:** Pull the headrest upward to the proper position and adjust the headrest height upward.

**Lowering:** Press the headrest locking button while pressing down on the headrest to the proper position.

**Disassembly:** Press the headrest lock button and simultaneously lift the headrest upward to remove the headrest.

**Installation:** Align the headrest with the mounting holes and push down to the locking position. Press the headrest lock button while adjusting the headrest downward to install the headrest.

**▲ WARNING**

- The headrest should be adjusted correctly according to the height of the driver and occupant in order to obtain the best protection effect.
- Adjust the seat headrest so that the center of the headrest is level with the eyes of the driver and passengers.
- The lowest position of the seat headrest is the non-use position and requires the headrest to be raised and locked before use.
- Do not drive the vehicle with the headrest removed. In the event of an incident or rapid acceleration or deceleration, seats without headrests do not provide the necessary protection for the head and may cause serious injury.

**FRONT SEAT HEATING/ VENTILATION\***

Touch the Seat Settings icon in the bottom bar of the infotainment screen **⏸** to enter the "Seat

Settings" interface, where you can set the seat heating and ventilation functions for the front seat.

Tap the corresponding seat heating button  to cycle through: heating off → heating level 3 (maximum) → heating level 2 → heating level 1 (minimum) → heating off.

Tap the corresponding seat ventilation button  to cycle through: ventilation off → ventilation level 3 (maximum) → ventilation level 2 → ventilation level 1 (minimum) → ventilation off.

Touch the "Settings" button in the seat setting interface to turn on/off the automatic seat heating/ventilation function. With the automatic seat heating feature turned on, when the temperature is low and there is an occupant in the front seat, the system will automatically turn on the seat heating. With the automatic seat ventilation feature turned on, when the temperature is high and there is an occupant in the front seat, the system will automatically turn on the seat ventilation.

### WARNING

- If you are sensitive to temperature changes, do not use the seat heating function to avoid burns or discomfort.
- Do not use the heating function when the seat is wet.
- Do not use the seat heater at the highest setting for a long period of time to avoid burns to the driver and occupants.
- Do not use any insulating items, otherwise it may cause an overheating risk to the seat heating system.
- Do not place sharp objects on the seat to avoid damage to the heated seat.
- Do not use liquid products to clean the seat.

### ATTENTION

- Do not kneel on the seat or apply excessive localized pressure to the seat, as this may damage the electrical parts inside the seat.
- If there is no temperature change or the seat is hot for a long time after turning on the seat heating function, you should turn off the seat heating function immediately and contact an authorized dealer in time for check and repair.

### NOTE

- Once the temperature of the seats or the temperature of the cockpit reaches the desired temperature, it is recommended to turn off the seat heating to reduce the vehicle energy consumption.
- The applications and control functions of the infotainment screen bottom bar can be customized through the "Vehicle Settings - Display - Customize Bottom Bar" interface.

## REAR SEAT ADJUSTMENT

### FOLD THE REAR SEAT BACKREST

The steps to fold the rear seat backrest are as follows:



1. Pull the rear seat backrest unlocking buckle.

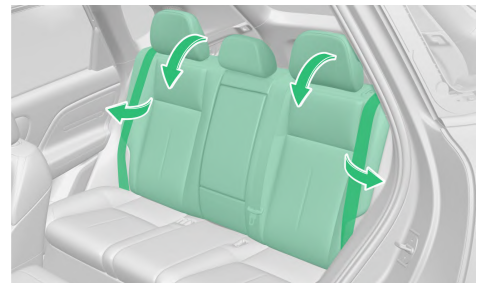

2. Pull the seat belt webbing on both sides of the rear seat toward the door, pull the rear seat backrest forward, release the seat belt webbing, and fold the rear seat backrest.

### RESTORE REAR SEAT BACKREST

The steps to restore the rear seat backrest are as follows:

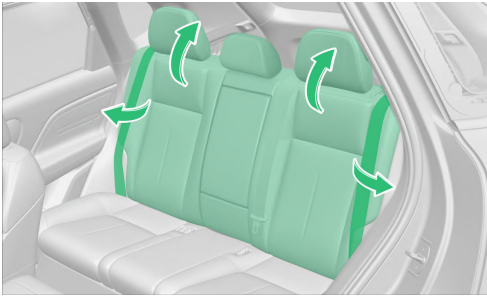

1. Pull the seat belt webbing on both sides of the rear seat toward the door, pull up the rear seat backrest and push it backward to the locking position. When you hear a "click" sound and the red indicator at the unlocking buckle is completely hidden, the backrest is fully locked.
2. Loosen the seat belt webbing, and try pushing the seat backrest back and forth to make sure it is securely locked.

#### ⚠ ATTENTION

- When folding the rear seat, make sure that there are no objects on the rear seat and that the seat belts are not connected, otherwise the rear seat may be damaged.
- When folding and restoring the rear seat backrest, operate slowly to avoid damage to the rear seat belts or abnormal function caused by rapid folding of the backrest.

#### 🔑 NOTE

- The headrest should be adjusted to the lowest position when folding and restoring the rear seat backrest.
- When an occupant is seated in the rear seat, the seat headrest must be raised to a position appropriate for the occupant's head.
- When the backrest is not locked, the red marking at the location of the unlocking buckle is exposed to alert the occupant that the backrest is not locked.

## REAR SEAT HEADREST HEIGHT ADJUSTMENT

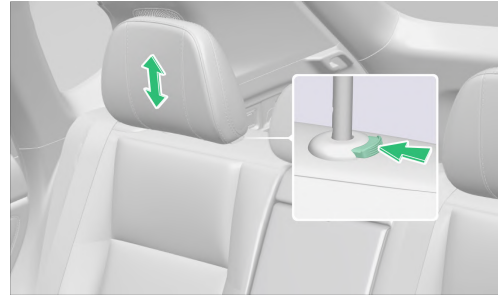

**Elevation:** Pull the headrest upward to the proper position and adjust the headrest height upward.

**Lowering:** Press the headrest locking button while pressing down on the headrest to the proper position.

**Disassembly:** Press the headrest lock button and simultaneously lift the headrest upward to remove the headrest.

**Installation:** Align the headrest with the mounting holes and push down to the locking position. Press the headrest lock button while adjusting the headrest downward to install the headrest.

#### ⚠ WARNING

- The headrest should be adjusted correctly according to the height of the occupant for optimum protection.
- Adjust the seat headrest so that the center of the headrest is level with the occupant's eyes.
- The lowest position of the seat headrest is the non-use position and requires the headrest to be raised and locked before use.
- Do not use the seat with the headrest removed. In the event of an incident or rapid acceleration or deceleration, seats without headrests do not provide the necessary protection for the head and may cause serious injury.

## WINDSHIELD WIPER AND WASHER

### CONTROLLING THE FRONT WIPER



Toggle the wiper switch at the end of the wiper control lever to select the wiping frequency.

#### Status 1\*

 Reset: The wiper keeps in the initial position and does not move.

 AUTO: The wiper can automatically select the wiping frequency or turn off according to the surrounding rainfall environment.

 Intermittent position: The wiper wipes at certain intervals.

 Manual low-speed: The wiper continues to work at a constant low speed.

 Manual high-speed: The wiper continues to work at a constant high speed.

#### Status 2\*

 Reset: The wiper keeps in the initial position and does not move.

 Intermittent low-speed position: The wiper automatically wipes at a low speed with longer intervals.

 Intermittent high-speed position: The wiper automatically wipes at a low speed with short intervals.

 Manual low-speed: The wiper continues to work at a constant low speed.

 Manual high-speed: The wiper continues to work at a constant high speed.

#### NOTE

- If the front windshield is contaminated with dirt or foreign substances (snow, gum, etc.), these should be carefully cleared beforehand. Failure to do so may result in damage to the wiper blades or the internal mechanism of the wipers.
- Before using the wiper in winter, make sure the wiper blade is not frozen to the windshield.
- Before washing the car, make sure that the windshield wipers are in the off position.

### WASHING THE FRONT WINDSHIELD



Press and hold the washing switch button. The front washer will spray washing fluid, followed by three low-speed wiping cycles from the wiper. After a few seconds, the wiper will perform an additional single wipe before ceasing operation.

#### ATTENTION

- Do not use the wiper when the windshield is in a dry status or the washing fluid in the washer fluid reservoir is empty.

## EXTERIOR LIGHTING

### CONTROLLING VEHICLE LAMPS VIA THE INFOTAINMENT SCREEN

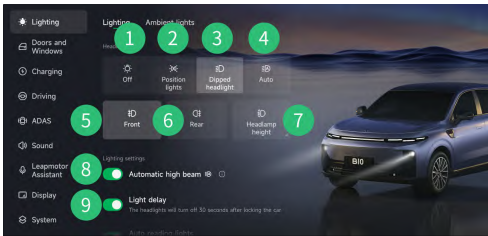

The exterior light switches are mainly integrated into the Infotainment Screen. The vehicle lights can be controlled in the "Settings - Lights" interface of the infotainment screen:

1. Light off button
2. Position lamp switch
3. Low beam on button
4. Automatic lights button
5. Front fog lamp button
6. Rear fog lamp button
7. Headlamp height adjustment button
8. Auto high beam switch
9. Lighting time delay switch

### TURN OFF THE LIGHTS

Tap the Lights Off button to turn off all exterior lights (only possible if the engine is switched off).

#### NOTE

- All exterior lights can only be turned off when the vehicle is not in the "READY" status.

### TURN ON POSITION LAMPS

Tap the position lamp on button to turn on front position lamps, rear position lamps, license plate lamp, and interior switch backlight.

### TURN ON THE LOW BEAM

Tap the low beam on button to turn on the position lamps and low beam.

### TURN ON THE AUTOMATIC LIGHTS

Tap the automatic lights button to turn on the automatic lights function. With the automatic lights function on, the vehicle automatically turns on or off the low beam and position lamps based on the intensity of light outside the vehicle detected by the sensors.

### FRONT FOG LAMP

Tap the front fog lamp button to turn on the front fog lamp. Tap the button again to turn off the front fog lamp.

### REAR FOG LAMP

Tap the rear fog lamp button to turn on the rear fog lamp. Tap the button again to turn off the rear fog lamp.

### HEADLAMP LEVELING



Tap the headlamp height adjustment button to enter the "Headlamp Height Adjustment" interface. Tap to select the gear value to adjust the headlamp height.

### AUTOMATIC HIGH BEAM

Turn on the auto high beam function in the infotainment screen, the vehicle can automatically switch between high and low beams according to the brightness of the ambient light source during driving, and automatically switch to high beams when the vehicle detects that the ambient environment is darker and that there are no traffic participants in front of it, which meets the conditions for turning on the auto high beam.

### HOME DELAY LIGHTING

Turn on the lighting delay function in the infotainment screen. When the outside light is low,

after locking the vehicle, the position lamps and low beam light up for a period of time and then go out.

### **▲ WARNING**

- When driving in fog, turn on the fog lamps and slow down, and honk the horn to alert other pedestrians and vehicles.

### **◆ NOTE**

- In humid environments, when there is a significant temperature difference, moisture may appear inside the headlamps and tail lamps. If the moisture disappears completely or to a large extent within a short period of time after the lights are turned on, it does not mean that the headlamps and tail lamps have a fault.

## CONTROLLING VEHICLE LAMPS THROUGH THE CONTROL LEVER

### TURN ON HIGH BEAMS

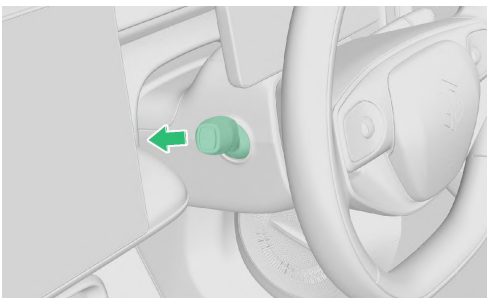

With the low beam in the ON status, press the light control lever away from the steering wheel as indicated by the arrow to turn on the high beam. At the same time, the high beam indicator light on the instrument cluster will light up.

### **▲ WARNING**

- High beams can dazzle drivers of other vehicles at close range and easily cause incidents, so please use them reasonably.

### **◆ NOTE**

- When the high beam is turned on, the low beam is turned off, and at the same time, the high beam is turned off.

### TURN ON THE PASSING LAMP

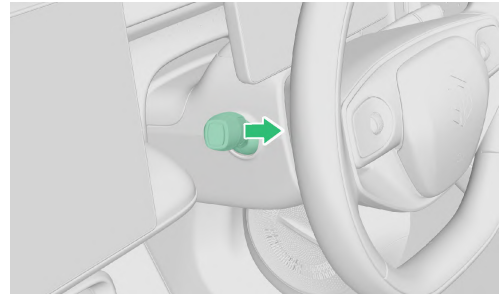

Toggle the light control lever towards the steering wheel to turn on the high beam. After you release the lever, the lever will automatically return to its original position and the high beam will go out. You can alert other road users of your intention to overtake by flashing your high beams.

### TURN ON THE DIRECTION INDICATOR LAMPS



After the vehicle is powered on, toggle the light control lever downward to turn on the left direction indicator lamp; toggle the light control lever upward to turn on the right direction indicator lamp.

After the vehicle is started, lightly toggle the light control lever downward, the left direction indicator lamp flashes three times, and the light control lever automatically resets; lightly toggle the light control lever upward, the right direction indicator lamp flashes three times, and the light control lever automatically resets.

## HIGH-MOUNTED STOP LAMP AND STOP LAMP

When the brake pedal is pressed, the high-mounted stop lamp and stop lamp come on.

## REAR REVERSING LAMP

After the vehicle is started, when the gear is shifted to the R gear, the reversing lamp lights up; when the gear is shifted out of the R gear, the reversing lamp goes out.

## INTERIOR LIGHTING

### FRONT READING LIGHT

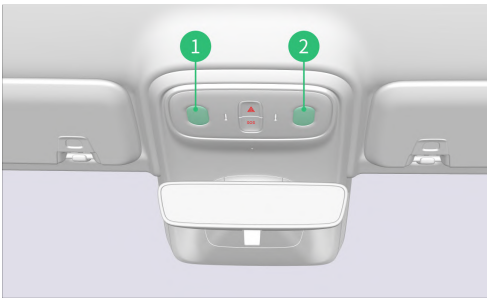

1. Left front reading light
2. Right front reading light

When the front reading light status is off, press the left/right front reading light to illuminate the left/right front reading light, and press again to turn off the front reading light on the corresponding side.

The automatic reading light function can be enabled through the infotainment screen "Settings - Lighting" interface. After the function is enabled, the reading light will automatically turn on or off according to the door and the overall vehicle power status.

### WARNING

- Avoid using the front reading light when driving at night. Bright lights may affect the driver's ability to drive safely and cause traffic incidents.

## VANITY MIRROR LIGHT

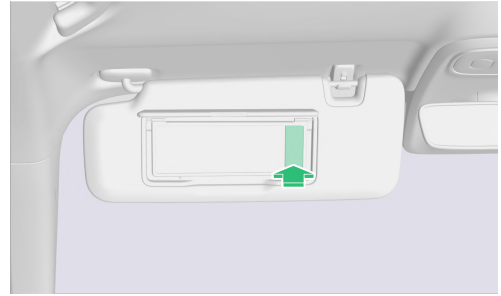

Flip down the sun visor, open the vanity mirror cover, and the vanity mirror lamp will light up. Close the vanity mirror cover, and the vanity mirror lamp turns off.

## AMBIENT LIGHT\*

Ambient light improves interior brightness in low light conditions and creates a softly lit environment in the cockpit.

In the "Settings-Lighting-Ambient Light" interface of the infotainment screen, the following settings can be made for the ambient light:

- Set ambient light on/off/auto.
- Ambient light color adjustment.
- Set ambient light static/monochrome flashing/color changing flashing effect.
- Adjust ambient light brightness.
- Turn on/off ambient light. After the light language is turned on, in specific scenarios (charging status, vehicle start-up, and other scenarios), the corresponding light effect display will be performed automatically.
- Turn on/off the music rhythm. When turned on, you can set the light and shadow mode/dynamic mode/canon mode.

## TRUNK ILLUMINATING LIGHT

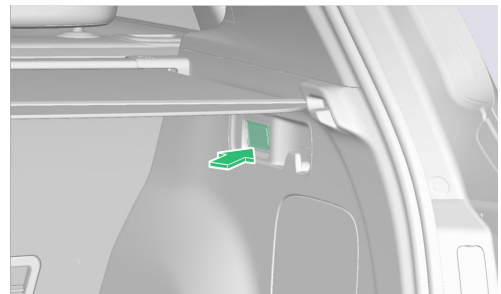

Open the liftgate and the trunk light turns on.  
Close the liftgate, and the trunk light turns off.

## A/C CONTROL SYSTEM

### FRONT VENT

#### DISTRIBUTION OF FRONT VENT POSITIONS

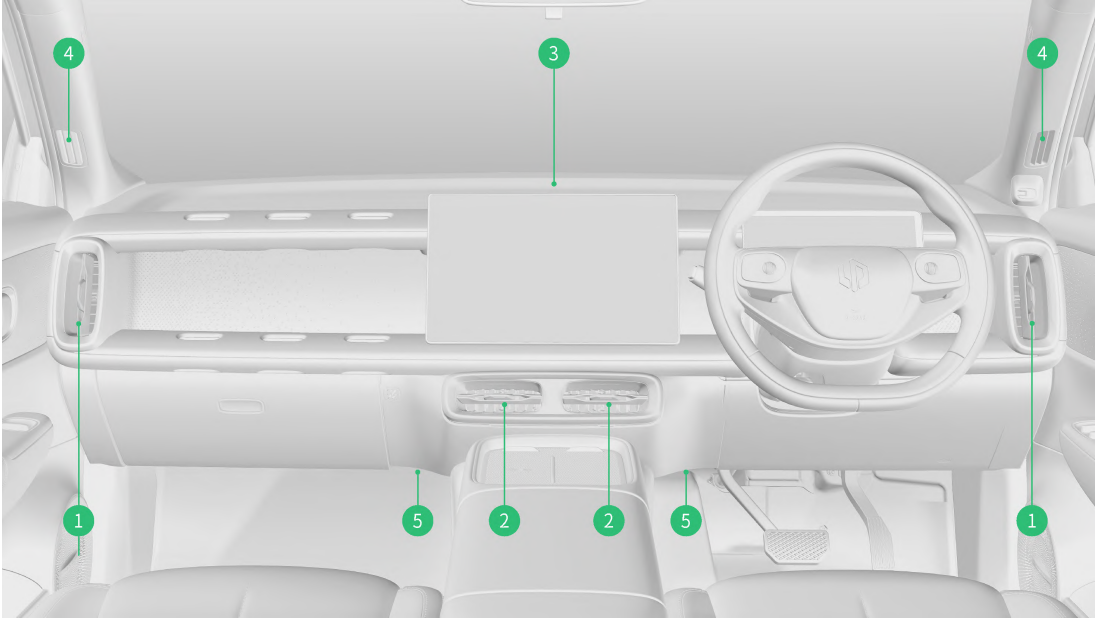

- 1. Driver seat vent
- 4. Side defrost vent

- 2. Front central vent
- 5. Front row foot vent

- 3. Front defrost vent

## DRIVER SEAT VENT ADJUSTMENT

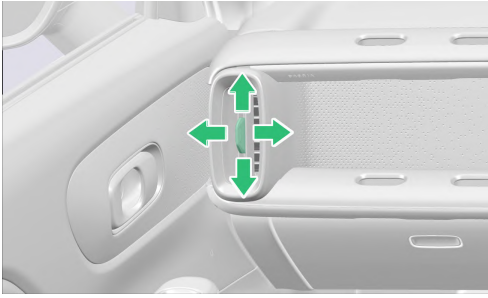

Toggle the vent lever left or right to adjust the direction of vent airflow.

Push the vent fork up and down to adjust the vent lever; pushing it all the way up can close the vent.

## FRONT CENTRAL VENT ADJUSTMENT

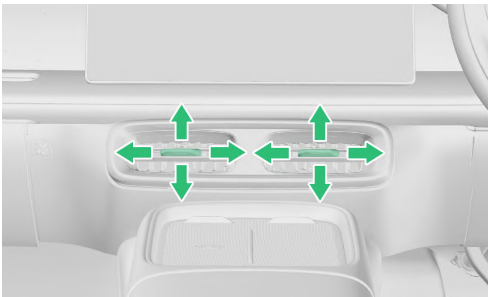

Toggle the vent lever up and down to adjust the direction of airflow from the vent.

Push the vent lever left and right to adjust the airflow of the vent, and push the toggles on both sides inward to the end to close the vent.

## REAR SEAT VENT

### REAR SEAT CENTRAL VENT ADJUSTMENT

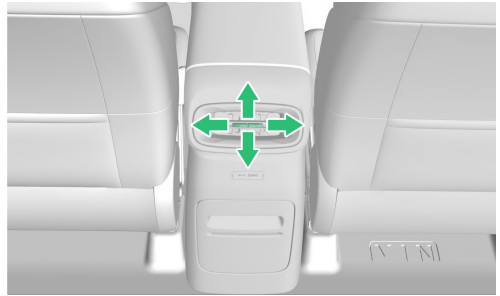

Toggle the vent lever up and down to adjust the direction of airflow from the vent.

Push the vent lever left and right to adjust the airflow of the vent, and push the toggles on both sides inward to the end to close the vent.

## A/C CONTROL PANEL



- |  |  |  |
|--|--|--|
| 1. A/C setting button                  | 2. Ventilation button                      | 3. Cooling button                              |
| 4. Heating button                      | 5. Auto button                             | 6. Inside air and outside air button           |
| 7. Rear windshield defrost button      | 8. Front windshield defrost button         | 9. Front passenger side temperature adjustment |
| 10. Driver side temperature adjustment | 11. Airflow level adjustment               | 12. ECO mode button:                           |
| 13. Maximum cooling button             | 14. A/C On/Off button                      | 15. Feet-blowing mode                          |
| 16. Face-blowing mode                  | 17. Windshield-blowing and defrosting mode |  |

## TURN A/C ON/OFF

Tap the "A/C On/Off" button to turn the air conditioning system on or off.

## TEMPERATURE SETTING

Scroll the number up and down to adjust the A/C temperature. Temperature regulation range: LO (18°C)~HI (32°C).

### NOTE



- This model has single-zone A/C. The temperatures on the driver side and the front passenger side are adjusted synchronously.
- The temperature value displayed on the infotainment screen is the target value for the set temperature, not the actual value of the temperature inside the vehicle.

## AIR VOLUME SETTING

Drag or tap the air volume adjustment bar to adjust the vent air volume. The minimum airflow level is Level 1, and the maximum level is Level 7.

## AIR OUTLET MODE SETTING:

Tap the corresponding air outlet direction button to select the current air outlet mode:

- Face-blowing mode: Tap the  mode button, the air will blow out from the front center vent, driver seat vent, and other vents.
- Feet-blowing mode: Tap the  mode button, the air will blow out from the front and rear foot vents.
- Windshield-blowing and defrosting mode: Tap the  mode button, the airflow will blow out from the front defrost vent and side defrost vent.

### NOTE

- Face-blowing mode, feet-blowing mode, and front windshield defrost mode can be turned on in combination according to actual needs.

## INSIDE AIR/OUTSIDE AIR MODE

Tap the "Inside Air and Outside Air" button to switch the air circulation mode among automatic circulation, Inside Air, and Outside Air.

- Automatic circulation: Automatically adjusts the air circulation mode according to the indoor and outdoor environmental conditions.
- Inside Air: The air conditioning system uses only the air inside the vehicle for circulation and does not draw air from outside.
- Outside Air: The air conditioning system draws fresh air from outside the vehicle, filters, cools, or heats it inside the air conditioning system, and sends the treated air into the interior.

### WARNING

- Do not use the Inside Air mode for a long time, as this will increase the concentration of carbon dioxide in the vehicle, which is not conducive to maintaining the awake status of the driver and passengers.
- When driving on dusty roads, turn on the Inside Air mode.
- When there is a large difference in ambient temperature and humidity between the inside and outside of the vehicle, the use of the Inside Air mode is likely to lead to fogging of the windows and windshield, which may affect the driving view and lead to traffic incidents.

## AUTOMATIC AIR CONDITIONING MODE

Tap the "Auto" button to turn on the automatic air conditioning mode, and the following items will be controlled automatically according to the set temperature value:

- Vent air volume.
- Air outlet mode.
- Inside Air/Outside Air mode.

### NOTE

- In automatic air conditioning mode, the recommended setting temperature is 22°C to 26°C for the best ride comfort.

- In automatic air conditioning mode, the system uses Inside Air mode to enhance cooling.

## COOLING MODE

Tap the “Cooling” button to turn on cooling mode.

### ⚠ ATTENTION

- Make sure the grille shutter in front of the windshield is not blocked (e.g., fallen leaves or snow).
- Do not place any objects on the instrument panel to avoid covering the vent and affecting the front windshield defogging.
- Do not rest inside the vehicle for long periods to avoid breathing difficulties or suffocation when the windows are closed or ventilation is poor.

### 🔑 NOTE

- When the temperature outside the vehicle is below  $-2^{\circ}\text{C}$ , the system cannot turn on the cooling mode.
- Tap the Heating button in cooling mode, the system exits cooling mode and enters heating mode.
- In cooling mode, condensate water will be discharged outside the vehicle through the water pipe. Therefore, water leakage under the vehicle is a normal phenomenon.
- The A/C functions can be controlled via intelligent voice or the Leapmotor App.

## HEATING MODE

Tap the “Heating” button to enter heating mode.

### 🔑 NOTE

- Turning on the A/C Inside Air mode can improve heating.
- If the front or rear windows are fogged, do not try to defog by turning on the heating mode; instead, turn on the front and rear windshield defrost function to achieve rapid defogging.

- Tap the Cooling Mode button in heating mode, the system exits the heating mode and enters the cooling mode.
- Using the heating mode will accelerate the energy consumption of the vehicle power battery. It is recommended to use the seat heating function as much as possible and turn on the heating mode when necessary.

## VENTILATION MODE

Tap the “Ventilation” button to turn on ventilation mode (blowing natural wind).

### 🔑 NOTE

- When the ventilation mode is on, the air circulation mode switches to the Outside Air mode.

## MAXIMUM COOLING (AC MAX)

Tap the “Maximum Cooling” button to automatically execute the following settings:

- The air circulation mode is switched to Inside Air mode.
- Adjust the air volume to the maximum.
- The temperature is set to LO.
- The air outlet mode is face-blowing mode.

Tap again and the system exits the maximum cooling mode and automatically returns to the previous state.

### 🔑 NOTE

- Maximum cooling mode operates at the maximum cooling performance of the A/C and should be used appropriately according to the vehicle’s interior temperature and usage, and turned off timely to reduce power consumption and save battery level.

## FRONT WINDSHIELD DEFROST

Tap the “Front Windshield Defrost” button once, the system will turn on fast defrosting/defogging, the air volume will switch to Level 7, and the air circulation mode will be Outside Air mode.

Tap the “Front Windshield Defrost” button again, the system turns on automatic defrosting/

defogging, the air volume changes automatically, and the air circulation mode is Outside Air mode.

Tap the "Front Windshield Defrost" button a third time to turn off defrosting/defogging.

### ATTENTION

- When there is fog or frost on the windshield, the front windshield defrost function should be turned on immediately to ensure driving safety.

## REAR WINDSHIELD DEFROST

Tap the "Rear Windshield Defrost" button to turn on the rear windshield defrost function, and the system electrically heats the rear windshield glass and exterior rearview mirrors.

### NOTE

- To prevent excessive battery level consumption, the rear windshield defrost function turns off automatically after 20min of working.

## ECO MODE

Tap the "ECO Mode" button, and the A/C enters energy-saving mode.

## A/C ANTI-MOLD MODE

Tap the "A/C Anti-Mold Mode" button in the air conditioner settings to turn the anti-mold mode on or off. After the mode is turned on, when the air conditioning system recognizes that the evaporator is at risk of condensation, after it is turned off, the blower continues to run for a period of time, blowing dry the remaining moisture on the evaporator to prevent the evaporator from harboring mold or bacteria due to prolonged wetness.

## LEAPMOTOR APP

### LEAPMOTOR APP DOWNLOAD

Before using your phone to remotely control the vehicle, please download the Leapmotor App.

- iPhone users can search for and download the Leapmotor App through the Appstore.
- Android phone users can search for and download the Leapmotor App in the app market.

## USER REGISTRATION AND LOGIN

In the "Registration" interface, enter the email account you reserved when you purchased the car, tap "Next", follow the prompts to set the password, account, and privacy preferences, and complete the verification by clicking the verification link received via email. Then, log in again.

## BINDING/UNBINDING VEHICLE

After logging in, in the interface of "Personal Center-Add Vehicle", tap the "Scan Code" button and scan the 2D (System-Security-Owner Binding Authentication) code on the infotainment screen to bind the vehicle.

In the "Personal Center" interface, enter the "My Vehicles" management interface to unbind vehicles.

### NOTE

- If the email account logged into the App is not the one used when purchasing the car, the scan code authentication will fail.
- After the vehicle binding is completed, you can view your vehicle information, including vehicle location, driving mileage, and vehicle status.

## REMOTE CONTROL

You can remotely operate your vehicle through the Leapmotor App, including vehicle lock/unlock and turning on the A/C.

## VEHICLES

In the "Car" screen, you can get information about your vehicle and control many functions remotely:

- Vehicle status: Display the current vehicle door status, vehicle remaining range, fault and other status information.

- Quick access toolbar: can quickly operate vehicle unlocking, trunk, windows, and other functions.
- In-vehicle climate control: you can set the in-vehicle climate control remotely.
- Digital key: Bluetooth key function can be set.
- Vehicle Find & View: Displays the real-time location of the vehicle.
- One-touch car preparation: can set the car preparation function.
- Vehicle Mileage: allows you to view the vehicle's trip energy consumption.

#### NOTE

- When the vehicle enters the "READY" status, the A/C function on the Leapmotor App cannot be used.
- If you leave the vehicle unlocked for 3 minutes after exiting, the Leapmotor App will send a reminder.

## CHARGING CENTER

In the "Charging Center" interface, you can set the following functions:

- Set the charging limit.
- Scheduled charging.
- Schedule battery preheating.

## MAP

Tap the "Map" card to enter the map interface. In the "Map" interface, you can view the current location information of your vehicle, use Remote Horn to find your vehicle, and search for your destination at the top for navigation.

## DIGITAL KEY

In the "Car" interface, tap the "Digital Key" icon to enter the digital key interface. On the "Digital Key" screen, you can complete the following settings:

- Enable/disable the Bluetooth key function.
- Unlocking/locking method setting: automatic unlocking, automatic locking, door handle unlocking/locking.
- Enable/disable latching beep.
- Performs fault diagnosis functions.
- Induction zone setting, with customizable unlock distance.

#### NOTE

- Carrying the phone close to the vehicle within a certain range will automatically unlock or lock it, or you can lightly touch the driver seat door handle button to unlock/lock. When using, you need to turn on the phone's Bluetooth, allow access to location permissions, select always allow location access, enable precise location (iOS system)/ location switch (Android system), and enable the App auto-start function (Android system).
- The Leapmotor App location setting must be set to "Always" to avoid having no location information when the App is running in the backend.
- You need to enable the Leapmotor App auto-start function and enable backend running permissions.
- Not all cell phones currently support the seamless Bluetooth key feature; standard Bluetooth supports all cell phones.

## CUSTOM

In the "Custom" screen, you can complete the following settings:

- Drag the shortcut key icons to adjust the order.
- Quick functions such as unlocking/locking the vehicle, opening/closing the trunk, closing the windows, and warming up the battery.

## IN-VEHICLE CLIMATE CONTROL

Click the "Car" interface "in-vehicle climate control" card to enter the in-vehicle climate control interface, where you can remotely turn the A/C on or off, adjust the A/C temperature, set seat heating/ventilation\*, set steering wheel heating\*, set exterior rearview mirror heating, rapidly cool down or heat up, and schedule timed A/C.

## TRAVEL

Click on the "Vehicle Mileage and Energy Consumption" card in the "Car" screen to enter the Vehicle Mileage screen. In the "vehicle mileage" interface, you can view your accumulated mileage, the total energy consumption per 100 kilometers in the past 6 weeks, and the trip data of the past 7 days.

## ONE-TOUCH CAR PREPARATION

Click the "One-Touch Car Preparation" button on the "My Car" interface to enter the One-Touch Car Preparation interface. You can set the following functions in the "One-touch vehicle preparation" interface:

- Destination: this destination will be sent to the MMI when the setting is completed.
- A/C setting: you can switch the A/C mode and adjust the A/C airflow and temperature in the mobile app.
- Seat settings: Seat heating/ventilation\* status can be set.
- Steering wheel and exterior rearview mirror settings: you can set the steering wheel heating\* or exterior rearview mirror heating status.
- Appointment Vehicle Preparation: Set the appointment vehicle preparation time and repeat cycle.

## STORAGE DEVICES

### TRUNK



After opening the liftgate, you can load items in the trunk storage space. For greater storage needs, the trunk storage space can be extended by folding the rear seat.

#### **⚠ WARNING**

- When placing liquid items in the trunk, ensure the container is sealed and the liquid does not leak.
- Do not allow children to enter the trunk.
- It is strictly forbidden to store flammable and explosive items in the trunk.
- Hard or easily rolling items should be properly wrapped and reasonably bundled to avoid impact when the vehicle is braking or encountering bumps.
- Do not allow items to interfere with the closing of the liftgate.

#### **🔑 NOTE**

- Regularly cleaning out the trunk and reducing the load can lower energy consumption.

### FRONT STORAGE BOX AND CUP HOLDER

#### STORAGE BOX IN THE FRONT CENTER ARMREST

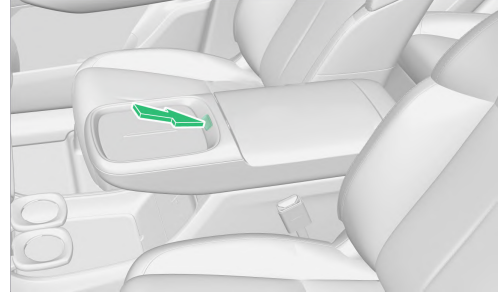

Press the storage box lid unlock button to open the center armrest storage box.

Snap the center armrest storage box closed.

#### **⚠ WARNING**

- Ensure that the central armrest storage box is closed while the vehicle is in motion.

### GLOVE BOX

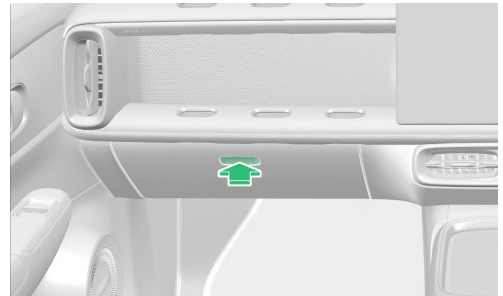

Press the glove box unlock button to open the glove box.

Push the glove box straight back to the closed position until you hear a snap, and the glove box will be closed.

#### **⚠ WARNING**

- To reduce the possibility of injury in the event of an incident or emergency braking, keep the glove box closed while driving.

- Do not pull hard on the open glove box to avoid damaging the glove box or injuring yourself.

### FRONT CENTER LOWER STORAGE BOX



The front center lower storage box is located under the instrument panel.

#### **▲ WARNING**

- Flammable, explosive, and splashable items are prohibited from being placed inside the storage box.
- Do not place eyeglasses, lighters, or spray cans in the storage compartment to avoid damage to the items caused by bumps.

### FRONT CUP HOLDER

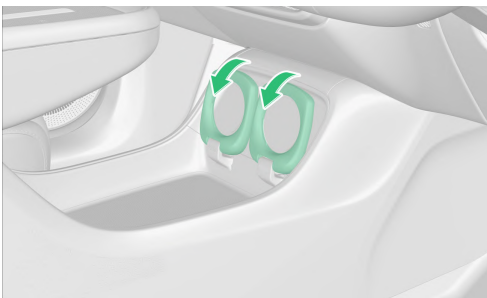

The front cup holder is located at the front end of the front center lower storage box and flips down for use.

#### **▲ WARNING**

- Do not use fragile cups, as they can cause secondary injuries in the event of a vehicle incident.

- Please ensure that the lid of the cup or beverage can is properly closed to prevent liquid from spilling during travel and causing accidental injury.

#### **◆ NOTE**

- Do not place items other than cups or beverage cans in the cup holder, as this may cause the items to fall or damage the cup holder.

### REAR SEAT STORAGE BOX AND CUP HOLDER

#### REAR SEAT CENTER STORAGE BOX



Pull the rear seat center storage box to open it.

Snap the rear seat center storage box closed.

#### **▲ WARNING**

- Flammable, explosive, and splashable items are prohibited from being placed inside the storage box.
- Ensure that the rear seat central storage box is in the closed status while the vehicle is in motion.

## REAR CUP HOLDER\*

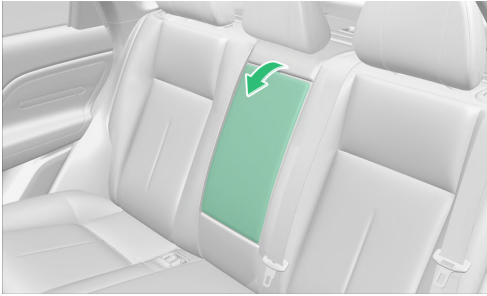

The rear cup holder is located at the rear end of the rear seat center armrest and can be used by flipping down the center armrest.

### ⚠ WARNING

- Do not use fragile cups, as they can cause secondary injuries in the event of a vehicle incident.
- Please ensure that the lid of the cup or beverage can is properly closed to prevent liquid from spilling during travel and causing accidental injury.

### 🔑 NOTE

- Do not place items other than cups or beverage cans in the cup holder, as this may cause the items to fall or damage the cup holder.

## DOOR STORAGE BOX

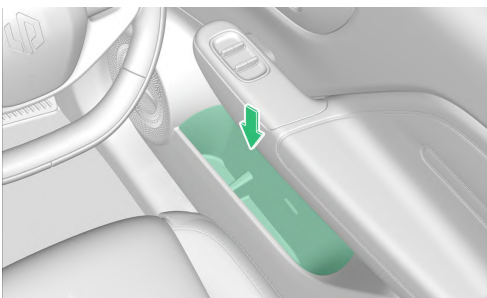

The storage slot on the door interior trim panel can be used to store drink bottles or other small items.

### ⚠ WARNING

- Flammable, explosive, and splashable items are prohibited from being placed inside the storage box.

### 🔑 NOTE

- Do not place heat-sensitive substances such as chocolate or medicines in the storage slot on the interior trim panel of the door.
- Do not place eyeglasses, lighters, or spray cans in the storage box to avoid damage to the items caused by bumps.

## FRONT ENGINE COMPARTMENT STORAGE BOX\*

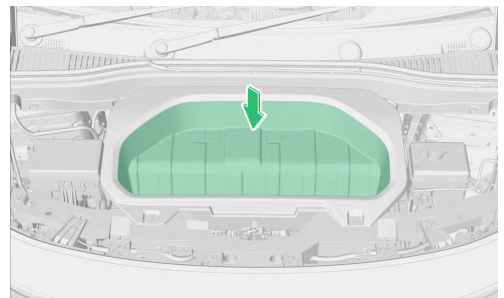

The bonnet has a storage box, which can be used by opening the bonnet.

### ⚠ WARNING

- Flammable, explosive, and splashable items are prohibited from being placed inside the storage box.

### 🔑 NOTE

- Do not place eyeglasses, lighters, or spray cans in the storage box to avoid damage to the items caused by bumps.

## STORAGE BAG ON THE FRONT SEAT BACKREST



After pulling open the storage bag behind the front seat, objects such as maps and newspapers can be placed inside.

### ⚠ ATTENTION

- Do not place heavy or sharp objects in the storage bag on the front seat backrest to avoid damaging the storage bags.

## ELECTRONIC DEVICE

### MOBILE PHONE WIRELESS CHARGER

#### MOBILE PHONE WIRELESS CHARGING INDUCTION AREA

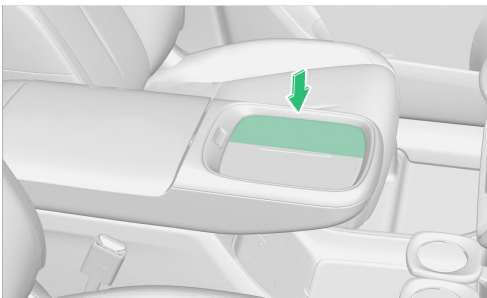

The mobile phone wireless charging induction area is located in the area shown on the console.

### TURN ON AND OFF MOBILE PHONE WIRELESS CHARGING

With all doors closed, tap the wireless charging status icon in the status bar at the top of the

infotainment screen to turn wireless charging on or off.

### MOBILE PHONE WIRELESS CHARGING STATUS DISPLAY

The operating status of the wireless charging of the mobile phone is displayed in the status bar at the top of the infotainment screen as follows:

Icon	Explanation
	Charging function is not on
	Charging function is on, but the mobile phone is not charging
	Charging in progress
	Charging completed
	Charging fault

### ⚠ WARNING

- Do not place any items between the mobile phone and the charging pad while charging. Non-metallic objects can cause degradation of charging performance. Magnetic cards or chip cards and similar items may be damaged. Keys, coins, and other metallic foreign objects may be heated, posing a driving safety hazard.
- Do not check the charging status of your mobile phone for a long period of time while driving to avoid a traffic incident.
- If you are using any medical electrical devices, such as a pacemaker or implantable cardioverter defibrillator, confirm with the manufacturer of the medical electrical device before using the mobile phone's wireless charging function to ensure that the wireless

charging will not affect the normal use of the implanted device.

### ⚠ ATTENTION

- Do not spill water on the wireless charging area to prevent water from entering the wireless charging module and causing damage to the electronic components.
- Do not place heavy objects in the charging area to avoid damaging the mobile phone's wireless charging system.
- When charging your mobile phone wirelessly, if you find a metal foreign object between the mobile phone and the charging area, do not immediately remove the foreign object by hand to avoid burns. Wireless charging should be turned off immediately, and wait for cooling before removing the foreign object.
- Do not spill small objects such as small stones, mud, bread crumbs, paper scraps, etc. into the charging area, as they may get into the internal fan and cause abnormal noise.

### 📌 NOTE

- The wireless charging system for mobile phone is not applicable to all mobile phones, but only to "Qi" certified mobile phones. We are not responsible for any incidents caused by the use of non-Qi certified mobile phones or other wireless charging receivers, nor for any resulting losses.
- You can only charge one mobile phone at a time.
- When driving on a bumpy road, wireless charging of mobile phones may experience intermittent stops and restarts. If the mobile phone deviates from the charging area and stops charging, it needs to be moved back to the rechargeable area.
- The wireless charging function of mobile phones requires the joint participation of the vehicle and the mobile phone, and if a fault occurs in either the vehicle or the mobile phone, it may result in the inability to charge.
- When the temperature is too high, charging may stop and will continue after the temperature decreases.

## 12V POWER SUPPLY INTERFACE

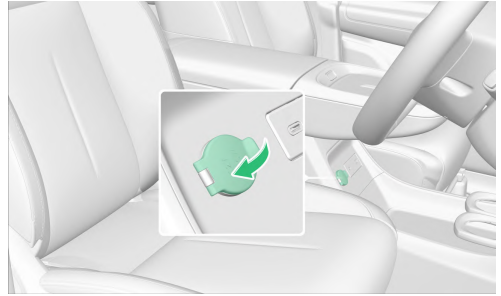

The 12V power supply interface is located at the rear end of the front center lower storage box and can be used by opening the trim cover.

## USB PORT

### FRONT USB PORT

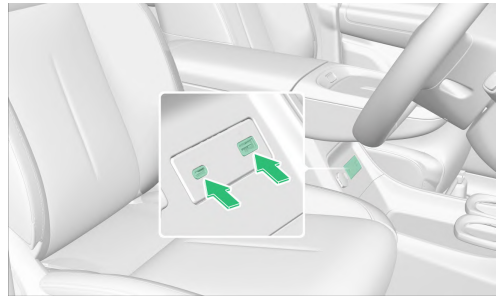

The front row is equipped with 1 Type A port and 1 Type C port. The Type A interface (supports 12W) can be used for charging and data transmission, and the Type C interface (supports 60W) can be used for charging.

### REAR SEAT USB PORT



The rear seat is equipped with 1 Type A port (supporting 12W) and 1 Type C port (supporting 15W) for charging.

**▲ ATTENTION**

- Do not insert other objects into the connector or allow any liquids to enter, as this may cause an electrical fault.
- Do not leave external devices inside the vehicle. The temperature inside the vehicle may rise, causing damage to external equipment.

## OTHER DEVICES

### SUN VISOR

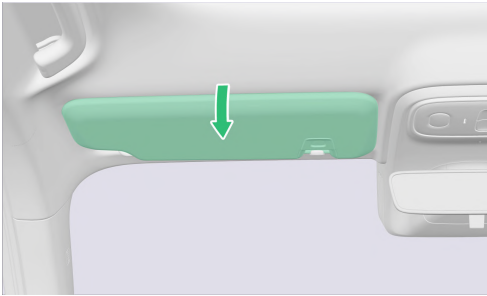

The sun visors are located above the driver and front passenger. To block the dazzling light coming from the front of the vehicle, simply flip the sun visor downward.

To block out glare from the side, remove the sun visor from the inner fixed support and turn the sun visor toward the side window.

**▲ WARNING**

- Be sure to adjust the sun visor while ensuring driving safety.
- A sun visor that is flipped down may interfere with forward visibility; be sure to retract the sun visor into its bracket if it is no longer needed.

### VANITY MIRROR

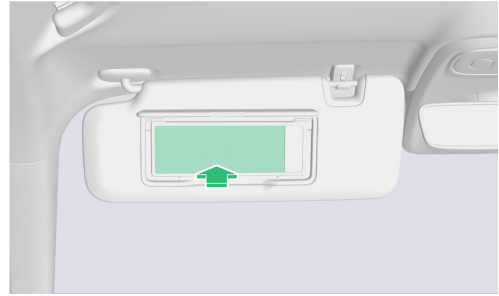

The vanity mirrors are located on the main and front passenger sun visors; after opening the sun visor downward, lift the vanity mirror cover plate upward.

**▲ WARNING**

- Drivers please do not use vanity mirrors while driving, and pay attention to driving safety.

### SAFETY HANDLE

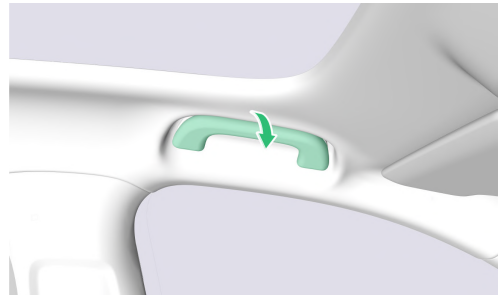

Use the safety handle to keep your body balanced when the vehicle is traveling fast or on bumpy roads.

**▲ ATTENTION**

- Do not pull on the safety handle when getting in or out of the vehicle or getting up from the seat.
- It is prohibited to hang any heavy objects from the safety handle.

## CLOTHES HOOK

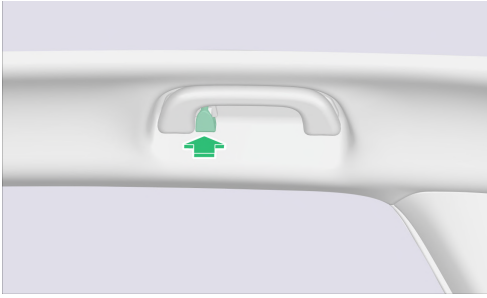

The coat hook is located next to the rear seat safety handle and flips down for use. It can be used to hang lightweight coats and hats.

### ⚠ ATTENTION

- Do not hang heavy objects.

## CARGO SHIELD

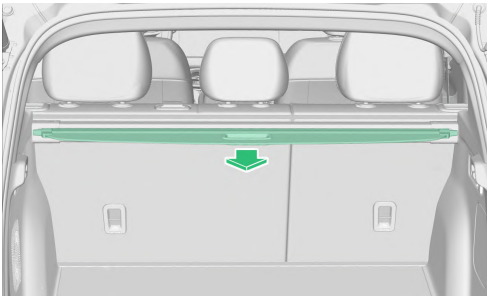

Cargo shields can be used to cover luggage for privacy and protection from direct sunlight. To use, hold the handle at the rear end of the cargo shield to pull out the curtain, and hang the limiting posts at both ends of the curtain into the sliding slots of the corresponding interior trim panels.

To retract, pull back on the cargo shield handle to disengage the cargo shield from the sliding slot, and slowly release forward to retract the cargo shield.

With the cargo shield retracted, hold the retaining ferrules at both ends of the cargo shield and compress them inward to remove the cargo shield.

To install the cargo shield, install one end of the cargo shield into the fixing slot, and in the direction of the arrow on the fixing ferrule,

compress the cargo shield fixing ferrule and hold it while installing the other end of the cargo shield.

### ⚠ WARNING

- Do not place heavy, hard, or rolling objects on the rear trunk cargo shield.
- Do not allow children to climb on the cargo shield, as this may damage the cargo shield or cause serious injury to children, or even endanger their lives.

### ⚠ ATTENTION

- When installing the cargo shield, it needs to be mounted securely to prevent the vehicle from injuring passengers in the event of an emergency.
- Place the removed canopy properly to prevent the vehicle from injuring passengers in the event of an emergency.
- Do not place any objects on the cargo shield to avoid damage to the cargo shield and injury to passengers of the vehicle in the event of an emergency.
- When the cargo shield is retracted, it needs to be fully retracted in place to avoid damage to the cargo shield and abnormal noise when the vehicle is in motion.

## DRIVING INSTRUCTIONS

### PRE-DRIVING INSPECTION

For the safety and driving comfort of you and your passengers, the following checks are recommended before each drive:

- Confirm that there are no obstacles around the vehicle.
- Check tires for damage, whether tire pressure is normal, and whether foreign objects are embedded in the tread, and take corrective action if necessary.
- Check whether the wheel nuts are loose.
- Check the vehicle chassis area for abnormalities such as water or other fluid leaks. (Water dripping after using A/C is a normal phenomenon)
- Check the chassis for foreign objects.
- Confirm that the vehicle lamps are working properly.
- Verify that all windows are clear and that the windows and rearview mirror have good visibility.
- Confirm the vehicle range information, and confirm that there is no warning message on the instrument cluster.
- Verify that the brake and accelerator pedal areas are free of debris and that operation is without interference.

#### WARNING

- Do not drive the vehicle wearing high heels or slippers.

### DRIVING SAFETY PRECAUTIONS

To ensure driving safety, please note the following:

- It is strictly prohibited to step on the accelerator pedal violently, so as not to shorten the service life of the motor and control unit.
- It is strictly prohibited to drive at high speed when going downhill, and you should slow down and proceed cautiously during turns.
- Try to avoid parking the vehicle for long periods of time on sloping surfaces.
- At the beginning of vehicle use, the power battery, chassis, and other parts have not yet reached the best status. At this time, the vehicle's driving mileage may deviate from the actual, which is a normal phenomenon.

- Please drive the vehicle safely and in strict accordance with traffic laws.
- Keep the vehicle in a safe driving status: tire bursts or mechanical faults are extremely dangerous. To reduce the likelihood of such faults, the vehicle's status should be checked frequently, and all required inspection items should be completed regularly.
- When the vehicle is on fire, leave the vehicle as soon as possible. If a high-voltage component or high-voltage wiring harness smokes and catches fire, it is prohibited to use a high pressure water gun to extinguish the fire.
- If exposed wires extend inside or outside the vehicle, do not touch the wires, or an electric shock incident may occur.
- Do not come into contact with liquid leaked from the vehicle. If skin or eyes come into contact with strong alkaline electrolyte leaking from a power battery, immediately flush with plenty of water or treat with boric acid solution, and seek medical attention as soon as possible to avoid serious injury.
- Floor mats must be correctly placed and the correct size floor mats used. The floor mats must not interfere with the normal use of each pedal, to avoid affecting the action of the pedals due to slippage of the floor mats, which may lead to traffic incidents.
- Do not leave children unattended in the vehicle, as if a child accidentally triggers one or more vehicle control devices, it may cause injury or even be life-threatening. Children may also mistakenly operate the vehicle causing it to move and result in a collision, thereby causing injuries or even endangering lives. Also, depending on the changes in ambient temperature, the interior of the car may reach extreme temperatures, thereby causing injury or even endangering life.
- Speed control: Excessive speed is one of the primary causes of traffic incidents, and the faster the speed, the greater the risk. Therefore, please choose the appropriate speed according to the actual road conditions and drive safely.
- Always wear the seat belt properly: in a collision incident, the seat belt is the best protection device. Airbags are only intended to supplement seat belts, not replace seat belts, so make sure that you and your occupants always wear seat belts properly, even if your vehicle is fitted with airbags.
- Please do not overload or force climbing, otherwise it will damage the drive motor and

electronic control unit (ECU) and shorten the service life of the whole vehicle.

## NEW VEHICLE BREAK-IN PERIOD

The break-in of a new vehicle is mainly to improve the surface quality and friction status of the moving parts. Proper break-in of a new vehicle can extend the vehicle's service life and improve the reliability and stability of the vehicle's operation.

The break-in mileage for a new vehicle is 1,000 to 2,500 km (621 to 1,553 miles).

The vehicle's power can only reach its maximum value after break-in; otherwise, due to insufficient power and premature heavy load usage, excessive initial wear of the drive motor parts will occur. During initial use, the following precautions should be observed:

- Check the connection and fastening of each part.
- Check the coolant fluid reservoir level, and check for leakage in all parts of the cooling system.
- Check the drive motor control unit and its all parts for oil leakage. If any abnormality is found, deal with it promptly.
- Check all parts of the steering mechanism for looseness and sticking.
- Check whether the brake system is working properly and whether there is leakage in the pipeline fittings.
- Check if electrical devices, lamps, and instrument cluster are working properly.
- Check whether the tire pressure meets the standard.
- Drive on flat and good roads as much as possible.
- Avoid sudden acceleration and sudden deceleration.

## CORRECT SITTING POSTURE

### DRIVER'S CORRECT SITTING POSTURE

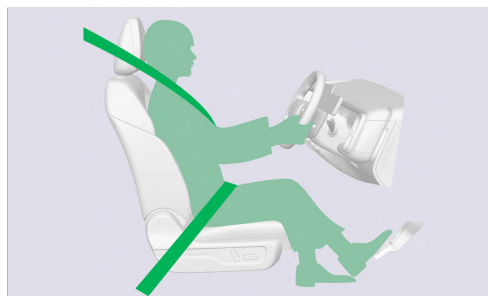

Proper driver posture facilitates driving operations and helps reduce the driver's fatigue. For the safety of the driver and occupants, it is recommended that the driver make the following adjustments:

- Adjust the driver's seat position to easily and effectively operate the pedals and each control switch.
- Adjust the driver's seat backrest so that the driver's back is fully against the seat backrest.
- Adjust the headrest so that the center of the headrest is level with the driver's eyes.
- Adjust the steering wheel position so that it is at least 25 cm from your chest, and you can hold the steering wheel when your arms are naturally bent.
- Correctly wear the seatbelt.

#### **⚠ WARNING**

- While driving, drivers should not adjust the seat, headrest, or steering wheel, as this may cause the vehicle to lose control and result in an incident.

### CORRECT SITTING POSTURE OF FRONT PASSENGER OCCUPANT

To ensure the safety of the front passenger occupant and reduce the risk of injury or death from incidents, it is recommended that the front passenger occupant make the following adjustments:

- Adjust the front passenger occupant seat position so that the front passenger occupant is the proper distance from the instrument panel.

- Adjust the front passenger occupant seat backrest so that the back of the front passenger occupant fits completely against the seat backrest.
- Adjust the headrest so that the center of the headrest is level with the front passenger occupant's eyes.
- Correctly wear the seatbelt.

### ▲ WARNING

- During driving, the front passenger occupant's feet should be placed in the foot area below the instrument panel. Do not place your feet on the instrument panel, stretch your hands out of the window, or sit cross-legged on the seat; otherwise, serious injuries may occur during emergency braking or in the event of an incident.

## CORRECT SEATING POSTURE FOR REAR PASSENGERS

To ensure the safety of occupants and reduce the risk of injury or death from incidents, it is recommended that rear seat occupants make the following adjustments:

- Adjust the headrest so that the center of the headrest is level with the rear seat occupant's eyes.
- Maintain an upright posture, with your back fully against the seat backrest.
- Correctly wear the seatbelt.

### ▲ WARNING

- When a child is on board in the rear seat, the appropriate child safety seat must be used.

## START DRIVING

### GEAR



R: Reverse gear

N: Neutral gear

D: Drive gear

P: Parking gear

The column shift is located in the lower right side of the steering wheel. When shifting gears, toggle the column shift up and down to shift between "R", "N", and "D". Press the side button to switch to Park (P), and at the same time, the current gear position is displayed on the instrument cluster.

"R" gear (reverse gear): switch to this gear when reversing. Always make sure that the vehicle has come to a complete stop before shifting to the R gear. When shifting from Neutral (N) to R gear, the brake pedal must be depressed.

"N" gear (neutral gear): When parking temporarily, you can switch to this gear.

"D" gear (drive gear): Put into this gear when driving normally.

"P" gear (park gear): Switch to this parking gear when parking.

### ▲ WARNING

- When shifting gears while driving forward, do not press the accelerator pedal to avoid accidents.
- Do not shift the vehicle to R gear while the vehicle is moving to avoid incidents.
- It is not recommended to drive the vehicle down a slope in N gear. It is not allowed even when the vehicle is not started.

- To prevent the vehicle from moving accidentally, ensure that the electronic parking brake is activated after the vehicle is parked and shifted into P gear.
- If you are unable to shift gears normally, contact the authorized dealer for check and repair in time.
- Before leaving the vehicle or when the vehicle is on a slope, make sure that the electronic parking brake is activated to prevent the vehicle from moving accidentally.

### ⚠ ATTENTION

- Make sure the vehicle is stopped before shifting to the R gear.
- It is prohibited to drive in gear when the car door is open.
- Make sure the gear is in Park (P) before the vehicle is powered down.
- Do not coast in neutral gear while the vehicle is in motion, as this is highly likely to damage the vehicle and create a hazard.
- When shifting to "R", "D", or "N" gear, press the brake pedal.
- It is prohibited to press the Park (P) button during non-emergency status driving.

## PEDAL



1. Brake pedal
2. Accelerator pedal

### ⚠ WARNING

- Do not store anything in the driver's foot space to prevent items from slipping into the pedal area, which will hinder the driver's operation of the pedals and cause traffic accidents.

- Before driving, it is necessary to check whether the pedal can be depressed and returned to its original position normally.
- The driver must wear shoes that fit properly and can sensitively perceive pedal movement.

## ELECTRONIC PARKING BRAKE (EPB)

### ENABLE THE ELECTRONIC PARKING BRAKE (EPB)

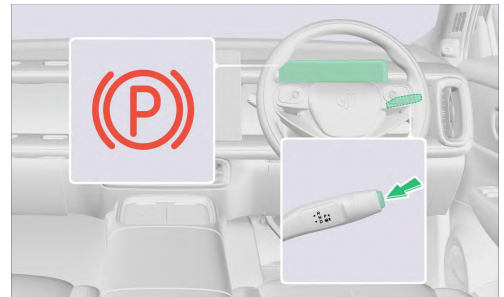

When the vehicle is stationary and shifted to P gear, the vehicle automatically applies the electronic parking brake, and the electronic parking brake indicator (P) in the instrument cluster lights up to indicate that the electronic parking brake is working.

### ⚠ ATTENTION

- The brake pedal should not be released early during parking, especially if the vehicle is parked on a slope, otherwise there is a risk of vehicle rolling.

### 🔑 NOTE

- When you need to park on a ramp, it is recommended to place wheel chocks or other hard objects that can prevent the vehicle from rolling at the tires when leaving the vehicle to avoid rolling due to prolonged parking on the ramp.



## RELEASE ELECTRONIC PARKING BRAKE

When the vehicle is powered on, step on the brake pedal and shift the gear out of P, the vehicle will automatically release electronic parking brake, and the electronic parking brake indicator  in the instrument cluster will go out, indicating that the electronic parking brake has been released.

- When applying or releasing electronic parking brake, it is normal for the motor to make a noise.
- Electronic parking brake cannot be applied/ released when the vehicle battery is discharged.
- When a vehicle is towed or enters the automatic car wash, it needs to be switched to the N gear and maintained, with the driver inside the vehicle and the vehicle power supply in the "READY" state.

 **NOTE**

## ELECTRONIC PARKING BRAKE INDICATOR

Icon	Status	Explanation
	Always On	Always On when the electronic parking brake (EPB) is applied, and illuminates without applying the EPB, indicating a system abnormality.
	Flash	Electronic parking brake (EPB) applying/releasing in progress; automatic emergency braking or degraded braking active; brake revolving drum mode active; or electronic parking brake (EPB) status unknown.
	Always On	Electronic parking brake (EPB) fault indication; electronic parking brake (EPB) in repair mode; or electronic parking brake (EPB) assembly status detection not completed

## AUTOMATIC EMERGENCY BRAKING

If the vehicle's service brake fails, automatic emergency braking can be achieved by continuously pressing and holding the P gear button.

Shift the vehicle to D gear or R gear, depress the accelerator pedal, and electronic parking brake (EPB) will exit the automatic emergency braking.

 **WARNING**

- Do not use automatic emergency braking unless it is necessary, as this may cause traffic incidents and shorten the service life of the parking brake system.
- When the vehicle is moving, the electronic parking brake must not be used to reduce speed unless necessary, because the brake only applies braking force to the rear wheels, which can easily cause traffic incidents.

## START THE VEHICLE



Start the vehicle in the following steps:

1. Unlock the vehicle and open the door to enter the vehicle.
2. Confirm that the gear is in P gear (parking gear).
3. Step on the brake pedal and place the NFC key in the wireless charging area of the mobile phone for more than 1s. The vehicle starts and enters the "READY" status. At the same time, the "READY" indicator on the instrument cluster lights up.

### ⚠ ATTENTION

- If the battery is discharged and the vehicle cannot be started, try emergency starting by jumper cables.
- Before starting the vehicle, please check and confirm that the seat, steering wheel, and interior/exterior rearview mirrors are adjusted to safe and comfortable positions.
- Before starting the vehicle, please check whether the brake pedal can be fully pressed down.
- Please check whether the surrounding environment meets the conditions for vehicle startup. If the conditions are not met, do not start the vehicle.

## START THE VEHICLE USING THE PASSWORD

Enable the password start function in the "Settings - System - Security" interface of the infotainment screen. After setting the operation password, you can start the vehicle as follows:

1. Unlock the vehicle and open the door to enter the vehicle.
2. Confirm that the gear is in P gear (parking gear).

3. Depress the brake pedal and enter the operating code in the infotainment screen pop-up window to start the vehicle.

### 🔑 NOTE

- If the infotainment screen is damaged and you cannot enter the code to start, we recommend contacting the authorized dealer as soon as possible.

## ACCELERATION MODE

In the "Settings - Driving" screen of the infotainment screen, you can select the acceleration mode as Comfort, Standard, or Sport.

- Comfort Mode: accelerator pedal response is smooth, and power output is soft.
- Standard Mode: Balances acceleration performance and ride comfort.
- Sports Mode: accelerator pedal response is sensitive, and power output is strong.

### ⚠ WARNING

- To ensure driving safety, please switch the acceleration mode in the Park status.

## GETTING STARTED

1. After the vehicle starts (READY status), depress the brake pedal and shift to the D gear.
2. Release the brake pedal, and lightly press the accelerator pedal to move the vehicle forward.

### 🔑 NOTE

- After turning on crawl control in the "Settings - Driving" screen of the infotainment screen, release the brake pedal and the vehicle will move forward slowly.

## PARKING

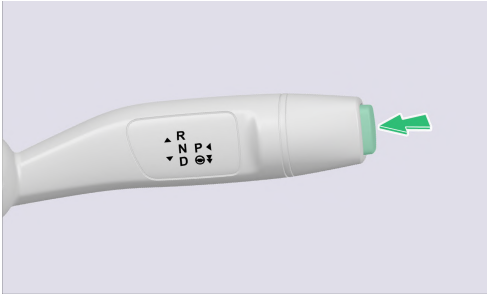

1. You should press down on the brake pedal while the vehicle is in motion until it comes to a smooth stop.
2. Switch the vehicle to P gear, and the electronic parking brake (EPB) indicator light  in the instrument cluster will light up. At this time, release the brake pedal, and the vehicle stops.

### ⚠ WARNING

- Do not park the vehicle near flammable and explosive materials.

### ⚠ ATTENTION

- When leaving the vehicle, you must turn off the vehicle power, take valuables and the vehicle key with you, and make sure that the windows, doors, and liftgate are locked.
- Try to park on a straight road and avoid parking on a steep slope.
- When parking on a slope, turn the front wheel towards the curb regardless of whether the vehicle faces the top or bottom of the slope.

## ENERGY RECOVERY

### REGENERATIVE BRAKING ENERGY RECOVERY

When the driver presses the brake pedal, the brake energy recovery system intelligently controls the ratio of the motor to the hydraulic brake in order to maximize the recovery of braking energy, thereby extending the vehicle's range.

In some cases pressing the brake pedal does not recover energy:

- The gear is not in D gear (it is recommended that you do not coast in neutral gear while driving).
- During torque intervention (gear shifting, tire slippage).
- Power battery fully charged.
- The power battery temperature is extremely high or extremely low.

### 🔑 NOTE

- The brake energy recovery system intelligently allocates the ratio of motor and hydraulic brake and has no effect on the vehicle's braking distance or effectiveness.

## COASTING ENERGY RECOVERY

When the vehicle is in a sliding status while driving, the energy recovery function is activated, and the motor converts a portion of the vehicle's kinetic energy into electrical energy, which is then stored in the high-voltage battery to extend the vehicle's range.

In some cases, the coasting energy cannot be recovered, for example:

- Shift to a gear other than the D gear (it is recommended that you do not coast in the neutral gear while driving).
- During torque intervention (gear shifting, tire slippage).
- Power battery fully charged.
- The power battery temperature is extremely high or extremely low.

The sliding energy recovery mode level can be set to strong, medium, or weak in the infotainment screen.

- Strong: The energy recovery during coasting is relatively strong, and the vehicle shows a distinct dragging sensation.
- Medium: The energy recovery during coasting is relatively medium, and the vehicle shows a medium dragging sensation.
- Weak: The energy recovery during coasting is relatively low, and the vehicle shows a weak dragging sensation.

### 🔑 NOTE

- Vehicles with coasting energy recovery have a shorter coasting distance at the same speed than vehicles without coasting energy recovery (e.g. conventional vehicles).

## ALCOLOCK INTERFACE

An alcolock is a device used to prevent drivers from starting their vehicle when their alcohol concentration exceeds a safe level. Vehicles equipped with alcohol interlock handheld devices require the driver to pass an alcohol breath test before starting the vehicle.

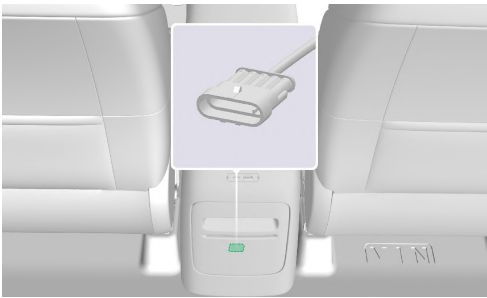

The vehicle has an alcohol lock port, located in the console, which supports future installation of an alcohol interlock handheld device.

### NOTE

- For installing an alcohol interlock handheld device, it is recommended to contact the authorized dealer.

## DRIVING AND ENVIRONMENT

### ECONOMICAL DRIVING

Vehicle driving mileage and power battery capacity are affected by driving habits, storage conditions, charging methods, and power battery temperature. Good driving habits and methods not only save battery level and increase the driving mileage of your vehicle, but also help to extend the service life of your vehicle.

- Smooth start and acceleration. Rapid start and rapid acceleration increase battery level consumption and shorten the service life drive motor. When driving the vehicle, try to avoid sudden pressing of the accelerator pedal when starting and accelerating. Smooth start and acceleration are beneficial for saving battery level and reducing motor loss.
- Use the energy recovery system properly. Under the premise of ensuring safety, the appropriate braking strength is selected under different road conditions to match the vehicle's driving status. To fully utilize the energy recovery system, apply the brake as gently as possible to slow down and avoid rapid deceleration.
- Maintain a stable driving speed. Maintain a steady speed according to road conditions and allowed speeds.
- Keep the vehicle aerodynamic drag low. Opening the windows at high speeds will significantly increase vehicle aerodynamic drag, leading to higher energy consumption. Close the windows when the vehicle speed is above 80km/h (50mile/h).
- Maintain normal tire pressure. Check tire pressure; tire pressure that is too low will increase rolling resistance, thereby causing energy consumption to rise.
- Reduce vehicle load. Avoid loading the vehicle with unnecessary heavy objects; excessive heavy objects will increase the load on the powertrain and lead to higher energy consumption.
- Do not change the size of tires arbitrarily. Using larger or wider tires will result in higher energy consumption.
- Do a good job of vehicle cleaning. The vehicle chassis should be kept clean and free of mud and other substances, which not only reduces the weight of the body but also prevents corrosion.
- Use A/C wisely. A/C can significantly increase energy consumption, so use A/C when necessary. At low speeds, windows can be opened for ventilation. Using recirculation mode when operating the air conditioner will be more energy efficient.
- Turn off functions that are temporarily not needed. Interior heating devices consume a lot of electricity (e.g. seat heating\*), and should be turned off when these functions are not needed.
- Perform maintenance regularly. Perform maintenance at the prescribed time to keep the vehicle in good condition. Good drive motor condition not only contributes to increased driving safety, but also helps to reduce energy consumption.
- Plan the driving route. Optimize the route and try to avoid congested sections. This both saves time and helps reduce energy consumption.

### WARNING

- Overloading of vehicles is strictly prohibited. When loading, try to distribute the load evenly between the front and rear axles, and do not exceed the load limit.

## DRIVING WITH A LOAD

For driving safety, please follow the precautions below when driving with a load:

- Place heavier luggage items as far forward as possible in the trunk.
- All luggage items must be properly secured in the trunk. Unsecured items can move back and forth in the trunk, shifting the vehicle's center of gravity, which may affect the vehicle's driving performance and safety.
- When transporting heavier items, the vehicle's driving performance will change due to the shift in the center of gravity, and there is a risk of an incident. Therefore, you must adjust your driving style and speed according to the actual situation.
- Do not exceed the allowable axle load and allowable weight. Exceeding the permissible axle load or permissible weight may affect the driving performance of the vehicle, resulting in traffic incidents, injuries, and damage to the vehicle.

### WARNING

- The liftgate must be in the closed status when the vehicle is in motion, otherwise an incident may occur.
- The load should be distributed and secured as evenly as possible to avoid incidents caused by emergency braking or sudden acceleration of the vehicle.

## DRIVING ON SLOPES

When going uphill or downhill, driving speed should be adjusted promptly according to the gradient to avoid overloading or damaging the drive system. The following should be noted when driving on slopes:

- Vehicles should be driven at low speeds when going uphill.

- It is strictly prohibited for the vehicle to power down or coast in neutral gear when going downhill.
- The brake must be checked for proper operation before descending a steep hill.

## HIGH-SPEED DRIVING

The higher the vehicle speed, the greater the injuries caused by traffic incidents. For the protection of others and your own safety, be sure to follow the following precautions:

- The higher the vehicle speed, the longer the braking distance. Therefore, the brake pedal should be controlled according to the vehicle speed and the required braking distance when braking.
- Driving in the rain not only reduces visibility, but also decreases the adhesion between the wheels and the ground, which can easily lead to loss of control of steering and braking, so you should drive at a reduced speed.
- Driving at high speeds through mountain passes, overtaking large vehicles, or passing through tunnels can be affected by side winds; reduce the vehicle speed at these times.
- When driving at high speeds, always hold the steering wheel firmly. When changing lanes or overtaking, the steering angle should be kept small to prevent the vehicle from drifting due to excessive speed. When braking is required, apply the brakes multiple times and avoid pressing the brake pedal all the way down to prevent the vehicle from veering off.
- Maintain a safe distance between vehicles. In general, on dry road with good braking, the following distance should not be less than the numerical value of the speed. For example, at a speed of 80 km/h (50 mile/h), the following distance should not be less than 80 m; at a speed of 100 km/h (62 mile/h), the following distance should not be less than 100 m. Always pay attention to the roadside distance signs. The following distance should be more than doubled in rainy, foggy, snowy, icy conditions, or when the road is wet.
- Strictly distinguish the functions of lanes, drive in separate lanes, generally use the main driving lane, and only use the overtaking lane when overtaking to ensure smooth traffic flow.
- When driving off the highway, pay attention to the intersection advance signs, divert the vehicle from the main lane into the deceleration lane to

slow down, and enter the general road via the ramp.

## NIGHT DRIVING

When driving at night, pay attention to the following matters:

- When driving at night, you should use the lamps properly.
- Turn on the low beams before starting the vehicle at night; do not use the high beams when following the vehicle in front of you.
- When passing through an intersection without traffic signal control, slow down and alternate the use of high and low beam headlights to signal.
- Use high beam at night when driving at speeds of 30km/h (19mile/h) or more on roads with poor lighting.
- When driving at night, due to the small area illuminated by lights, visual fatigue is likely to occur. One should observe carefully and drive at a low speed. And try to avoid overtaking; if you do need to overtake, you should continuously switch between high beam and low beam to signal the vehicle ahead.

### ▲ ATTENTION

- Before driving at night, check and ensure that all lamps of the vehicle function properly.
- When driving at night with lamps on, do not keep the high beams on for a long time.
- When meeting oncoming vehicles at night, turn off the high beams.

## DRIVING IN FOG

When driving in foggy weather, you must turn on your fog lamp and keep your speed as low as possible. When vehicles meet on the road, be sure to sound your horn to warn pedestrians and oncoming vehicles. When you hear another vehicle's horn, you should also respond by sounding your horn immediately to signal your vehicle's position. For the safety of others and yourself, please pay attention to the following:

- When driving in foggy weather, try to drive in the middle of the road. Please do not drive along the roadside to avoid collision with

vehicles temporarily parked on the side of the road waiting for the fog to clear.

- Before driving the vehicle on a foggy day, you should thoroughly check the vehicle's lighting system. Turn on your fog lamp, tail lamp, position lamp, and low beam while driving, and use the lights to improve visibility, see vehicles, pedestrians, and road conditions in front of you, and also let others see you. Also, do not use high beam when driving in fog.
- When driving in fog, do not press or release the accelerator pedal abruptly, and never perform emergency braking or turn the steering wheel sharply. If you must reduce the speed of the vehicle, first gently release the accelerator pedal, then lightly press the brake pedal multiple times in succession to control the vehicle's speed and prevent vehicle collision incidents.
- When traveling on streets and country roads, pay special attention to traffic at intersections and keep your speed low to avoid incidents with pedestrians or vehicles that suddenly come out of the intersection.

### ▲ WARNING

- The vehicle's lighting system should be checked before traveling, such as the front combination lamp and fog lamp. To prevent personnel injuries or even life-threatening situations caused by accidents during vehicle operation.
- Avoid driving vehicles when foggy weather occurs. Driving on foggy days with low visibility on the road makes it easy for traffic incidents to occur, resulting in injuries and even life-threatening situations.

## DRIVING IN RAINY AND SNOWY WEATHER

When driving a vehicle in rain or snow, please follow these safety precautions to ensure the safety of others and yourself:

- Try to keep your speed as low as possible when it is raining or on wet roads.
- When driving in the rain, do not slam down or quickly release the accelerator pedal, and do not apply emergency braking or turn the steering wheel sharply. When driving in rainy weather, if you need to reduce the speed of the car, first slowly release the accelerator pedal, then lightly press the brake pedal several times in a row to

control the speed of the car and prevent rear-end incidents.

- Start and accelerate gently and slowly; sudden acceleration will cause the wheels to idle and slip, causing the vehicle to slide sideways.
- Avoid sudden steering wheel turns; when turning, the steering wheel should be smoothly maneuvered at a safe speed. If you need to install anti-skid chains, you should choose the specifications applicable to this vehicle's tires, and strictly follow the anti-skid chain manufacturer's regulations before installation.
- When it rains, you are advised to drive with caution as visibility is reduced, vehicle windows are prone to fogging affecting the driver's vision, and roads are slippery, reducing the controllability of the vehicle.
- When it rains, you should turn on the heating function of the exterior rearview mirrors in a timely manner to prevent the accumulated raindrops on the mirrors from causing blind spots in the driver's vision.
- On cloudy days, days with heavy rain and fog, and days with poor visibility, fog lamps and low beams should be turned on promptly.
- When the rain is too heavy or there is lightning that prevents you from continuing to drive, park your vehicle in a location that is free of standing water to prevent your vehicle from being submerged, and turn on your hazard warning lamp to alert vehicles behind you.
- After a rainy day, the vehicle should be washed promptly to prevent the acidic substances in the rainwater from corroding the body paint.

### WARNING

- Driving conditions in rain and snow are more hazardous than in other seasons. When driving, you should take extra care and reduce your speed to avoid incidents that could result in injuries or even threaten life.
- Drive at low speeds in rain and snow. Low visibility and slippery roads in rain and snow make it easy for traffic incidents to occur, resulting in injuries and even life-threatening situations.

### ATTENTION

- The depth of water must be ascertained before entering a waterlogged roadway, and

the height of water must not exceed the lower edge of the vehicle body.

- After exiting from a waterlogged roadway, lightly press the brake pedal to check whether the brake is functioning properly. When the brake pads are wet, the braking performance will be significantly reduced and incidents will easily occur.
- If the electrical parts are short-circuited or if the power battery or drive motor is damaged due to water immersion, it is recommended to contact an authorized dealer.
- Do not restart the vehicle after water ingress has caused the power to go down. Disconnect the power supply immediately and contact an authorized dealer as soon as possible.
- If you need to drive through water, please pass through the waterlogged section at a steady and slow speed.

## WINTER DRIVING PRECAUTIONS

Winter driving conditions are more dangerous than other seasons. When driving, you need to be extra careful and should follow the cold season driving precautions to ensure the safety of others and yourself.

- Before driving in winter and other cold seasons, you must carefully check the safety equipment on your car: steering, brakes, lights, instrument cluster, horn, wiper, etc.
- In winter, roads are slippery after snowfall. Keep a steady speed when driving, and please do not perform hard acceleration, emergency braking, sudden steering, or other unstable operations.
- Be gentle and gradual when starting and accelerating to prevent tire slippage and side slipping.
- Park the vehicle promptly in an indoor parking space after use.
- Do not park the vehicle in snow or water to avoid water freezing and tearing the tires apart.
- Place wooden boards at the tire locations to prevent snow accumulation.
- Do not place the vehicle under a tree to prevent ice from falling and damaging the vehicle.
- The wiper arm can be raised when parked to prevent freezing onto the windshield, avoiding use that could cause the wiper blade to tear or the wiper motor to be damaged.
- Remove ice and snow from the surface of the vehicle in a timely manner. Ice and snow may

cause some of the vehicle's functions to malfunction and pose a safety hazard.

- Avoid accumulation of snow and ice under the mudguards: snow and ice accumulation under the mudguards can cause steering difficulties. When driving during the harsh winter months, you should stop from time to time and check for snow and ice buildup under the mudguards.
- Wipe the snow water off the combination lamp to prevent the snow water from freezing and cracking the combination lamp.
- Avoid door handles freezing due to snow and ice: Spray some deicing agent or glycerin on the surface of the door handle to prevent freezing.
- Try to choose flat ground for parking.
- When parking, open the door to cool down, and lock the door after a few minutes. Reduce the temperature difference between the inside and outside of the car to prevent the glass from freezing.
- In cold climates, the energy of any battery decreases, so the condition of the battery should be checked frequently to keep the battery level sufficient for starting use.
- In winter, you need to use a glass washing fluid that contains antifreeze.
- Regularly check the coolant level.
- It is recommended that you prepare some equipment and tools for use in case of an emergency. It is recommended to keep the following equipment in reserve: anti-skid chain, window scraper, signal flashing device, jumper cables, etc.

## TIRE ANTI-SKID CHAIN

Driving in harsh conditions such as snow or icy roads in winter can increase tire wear or cause other faults. To minimize winter faults, the following must be followed:

- Different countries and regions have different regulations for anti-skid chains, so you should refer to the regulations of each country and region before assembling anti-skid chains. Do not install anti-skid chains without understanding that regulations in each country and region may restrict the use of anti-skid chains.
- Anti-skid chains need to be mounted in pairs on the rear wheels.
- When driving on snowy roads, if you need to install anti-skid chains, please choose equivalent products that match the size and type of the vehicle's tires. Unsuitable anti-skid chains can

damage the vehicle's tires, wheels, suspension, braking system and body. Speeding, sudden acceleration, sudden braking, sudden turning, and other maneuvers are very dangerous.

- Emergency braking on snowy or icy surfaces can cause the vehicle to fishtail and skid. You should keep a proper safety distance from the vehicle in front of you and lightly press the brake pedal. Anti-skid chains installed on the tires can provide some friction, but they cannot prevent side-slipping from occurring.
- When installing anti-skid chains on tires, keep in mind that the vehicle may have insufficient power after the chains are installed. Drive carefully, even if the road conditions are good. Do not exceed the specified speed limit for anti-skid chains while driving, nor exceed 50km/h (31mile/h), whichever is lower.
- Do not use anti-skid chains on dry ground. Remove anti-skid chains after driving to snow-free roads.
- Do not install anti-skid chains when tire pressure is insufficient.

### NOTE

- Anti-skid chains are not included in the vehicle equipment scope. The above information is for your reference only.

## HOT WEATHER DRIVING

When driving a vehicle in hot weather such as summer, please follow the hot season driving precautions to ensure the safety of others and yourself.

- Do not expose your vehicle to the sun for long periods of time during the hot season, and do not place flammable items (e.g., lighters, confetti, cloth toys, etc.) on or near the instrument panel of your vehicle.
- Summer ambient temperature is high, and the vehicle is prone to overheating. Therefore, in summer, the vehicle cooling system inspection and maintenance should be strengthened, and the scale in the coolant expansion tank, waterways, and debris embedded between the radiator fins should be removed in a timely manner.
- Do not drive the vehicle wearing slippers or high heels.
- In summer's hot weather, you should frequently check whether the vehicle wiring is short-

circuit or aging, whether the plugs are loose, and whether the battery is in normal working status, etc., to prevent the vehicle from spontaneous combustion.

- The tire pressure inside summer tires rises with the temperature, making them prone to blowouts. When the tire pressure warning indicator lights up while driving, stop immediately and wait for the tire temperature to drop before driving again.

## PRECAUTIONS FOR DRIVING OVER WATERLOGGED ROADS

When driving through waterlogged roads, pay attention to the following:

- The depth of water must be ascertained before entering a waterlogged roadway, and the height of water must not exceed the lower edge of the vehicle body.
- Under no circumstances should you stop, reverse, turn off or start the vehicle in the water.
- When driving through waterlogged roads, maintain a steady and slow speed.
- Vehicle braking on waterlogged road surfaces will be slightly less effective than under normal status. At this time, you should keep driving at a low speed and press the brake pedal lightly several times in a row to restore normal braking performance.
- The vehicle needs to be driven at low speeds, otherwise waves may form in front of the vehicle, which could cause water to enter the front engine compartment or other parts of the vehicle.

The effect of water ingress inside HV parts:

- HV parts belong to electronic devices. After the vehicle is soaked, sun-drying, air-drying, and other methods cannot ensure that the moisture in the HV parts fully evaporates.
- Water ingress inside HV parts has a great impact on their own insulation. At the same time, moisture contains more conductive substances, which may cause internal short circuits in HV parts or put the high-voltage system at risk of short circuits. In this case, the overall safety performance and operational performance of the vehicle are seriously affected.
- Internal water ingress in HV parts has a significant impact on the product's protection level, pressure resistance, and other

performance aspects, posing a considerable safety risk.

### ATTENTION

- Certain parts of the vehicle such as the powertrain, chassis, or electrical system can be severely damaged while driving through water.
- The waves generated by oncoming vehicles may exceed the maximum wading height allowed for this vehicle.
- The water may hide depressions, mud pits, or rocks that can make wading more difficult.
- Do not drive in salt water. Salt can cause vehicle rust. All vehicle parts that have been in contact with salt water must be rinsed immediately with fresh water.
- After wading in the water, it is recommended to go to an authorized dealer to conduct a comprehensive inspection of the vehicle to check for hidden dangers and ensure driving safety.
- When the vehicle is cleaned or driven through deep water, the brake pads and brake discs become soaked with water. Applying the brake will greatly reduce the braking effect; the braking distance will be longer than under normal status, and the vehicle may pull to one side. The parking brake will also be unable to firmly hold the vehicle. At this time, you should first drive at a low speed and continuously lightly press the brake pedal to remove the residual water from the brake. After the braking effect returns to normal, you can then drive normally.

## PRECAUTIONS FOR DIFFERENT ROAD CONDITIONS

The following should be noted when responding to different road conditions:

- When traveling on roads with frequent crosswinds and gusts, you should slow down in advance and control your speed and steering.
- Avoid driving on objects with sharp edges or other road obstacles, as this may cause serious damage such as tire blowouts.
- When driving on bumpy roads or uneven roads, reduce the speed and drive at low speeds, otherwise you may scratch the chassis and cause damage to the vehicle.

- When traveling downhill, slow down in advance to avoid emergency braking, which can cause the brake system to overheat or wear out too quickly.
- When driving on smooth surfaces, be careful when accelerating or braking. Rapid acceleration or emergency braking may cause the tires to skid. When driving on icy or snowy roads, you should drive at low and steady speeds, avoiding rapid acceleration or emergency braking. Tires can be fitted with anti-skid chain as required.

## LOW-TEMPERATURE DRIVING

At low temperatures, tire performance decreases, grip is reduced, and sensitivity to impact damage increases. High performance tires (for summer use) have reduced traction at ambient temperatures below 5°C and are not recommended for use in ice/snow conditions. When the weather is cold, the tires may temporarily harden, and a rolling noise will be heard for the first few kilometers before the tires warm up.

## SAFETY WARNING SYSTEM

### ANTI-THEFT ALARM SYSTEM

The anti-theft alarm has the following statuses:

- **Vehicle arming:** When the vehicle is stationary and all doors are closed, operate the NFC or Bluetooth key to lock the vehicle. The direction indicator lamps will flash once, indicating that the vehicle has entered pre-arming mode. The vehicle will enter the armed status after a period of time. If any door is opened during the pre-warning armed period, the vehicle will exit the pre-warning armed status and enter the disarm status.
- **Vehicle disarm:** After successfully arming the vehicle, operate the NFC or Bluetooth key to unlock it. All direction indicator lamps will flash twice. Unlock the vehicle when the vehicle is in armed status. If no door is opened for a period of time, the entire vehicle will re-enter the armed status.
- **Anti-theft alarm:** After the system is armed successfully, if any door or liftgate is opened illegally, the turn signal will flash.
- **Theft disarm:** During the alarm, operate the NFC or Bluetooth key to unlock the vehicle and exit alarm mode. The direction indicator lamps will turn off. At this time, the vehicle is only disarmed

from the alarm status and not in a disarmed status. Operate the NFC or Bluetooth key again to unlock the vehicle. The vehicle will enter the disarmed status, and the direction indicator lamps will flash 4 times.

### ⚠ ATTENTION

- Modification, addition, or replacement of the vehicle's anti-theft alarm system and its parts may result in the vehicle being unable to start or the doors being unable to unlock or lock.

### 🔑 NOTE

- Do not leave the key inside the vehicle when leaving.
- Do not modify or dismantle the anti-theft system without authorization to avoid system malfunctions.
- Before locking the vehicle, ensure that no one is inside and that the windows are closed.
- The anti-theft system helps prevent vehicle theft but cannot completely avoid it. To ensure greater safety of the vehicle, please park the vehicle in a secure parking area and remove valuables and other personal belongings from the vehicle before leaving.

## ACOUSTIC VEHICLE ALERTING SYSTEMS (AVAS)

When the vehicle is traveling at a low speed, the acoustic vehicle alerting systems (AVAS) will emit a warning tone to pedestrians near the vehicle, alerting pedestrians and vehicles and improving driving safety.

### ACOUSTIC VEHICLE ALERTING SYSTEM (AVAS) ALARM

Beeps when the vehicle is moving forward and the speed is not greater than 30 km/h (19 mile/h).

A beep also sounds when the vehicle is reversing.

### ⚠ WARNING

- The acoustic vehicle alerting systems (AVAS) only alert pedestrians near the vehicle, and

the driver still needs to be aware of the current driving environment at all times.

### TIRE PRESSURE MONITORING SYSTEM (TPMS)

The tire pressure monitoring system, referred to as TPMS, can monitor and alarm the tire pressure and temperature.

#### TIRE PRESSURE MONITORING SYSTEM ALARM

The tire pressure monitoring system will give an alarm in the following conditions:

- The tire pressure is too low.
- The tire pressure is too high.
- The tire temperature is too high.
- The tire temperature is too low (occurs in some areas).
- No signal from sensor.

#### TIRE PRESSURE WARNING INFORMATION

If the tire pressure is abnormal or the TPMS fails, the tire pressure fault warning light  on the instrument cluster will light up, and the corresponding text warning message will be displayed.

#### WARNING

- Do not completely rely on the tire pressure monitoring system. Please check the tire conditions regularly, ensuring the tire pressure is normal and that there is no damage to the tires, such as punctures, cuts, or cracks.
- If the TPMS indicator lights up, you must immediately reduce your speed, avoid sharp turns and emergency braking, stop the car safely nearby, and check the tire pressure as soon as possible. When the tire temperature is too high, it is recommended to stop and rest until the tire temperature drops before continuing to drive.
- The TPMS can identify tires with low tire pressure. When the vehicle issues an under-pressure alarm for a particular tire, the driver should check the inflation pressure of the indicated tire as well as the tires that did not trigger an alarm.

- Different tire pressures or low tire pressure may increase tire wear, reduce driving stability, and lengthen the braking distance.
- Different tire pressures or low tire pressure can lead to sudden tire failure, tire blowout, and loss of vehicle control.
- Driving with low tire pressure will increase tire distortion, and the tire will heat up dramatically, which may lead to tire casing separation and tire blowout.
- Using tires with non-compliant air pressure can lead to incidents and tire damage, and it is the driver's responsibility to ensure that all tires are inflated to the correct pressure. Therefore, be sure to inflate all tires to the standard air pressure before driving. The TPMS will only work if the tire pressure is correct on all cold wheels.

### LANE DEPARTURE WARNING (LDW)

#### SYSTEM INTRODUCTION

The lane departure warning system, referred to as "LDW," monitors and identifies roadway lane lines in real time, collects data on the roadway ahead, and combines it with the vehicle's own driving data. When the driver has not turned on the turn signal and the vehicle deviates from the lane, the system will send out an alarm signal in advance to remind the driver to take corrective measures in a timely manner, ensuring the safety of drivers and occupants.

#### ENABLE LANE DEPARTURE WARNING SYSTEM

In the "Settings - Smart Driving - Active Safety" interface of the infotainment screen, turn on the Lane Departure Warning and Assist function, and then select "Warning" to turn on the Lane Departure Warning function.

#### TRIGGER LANE DEPARTURE WARNING SYSTEM

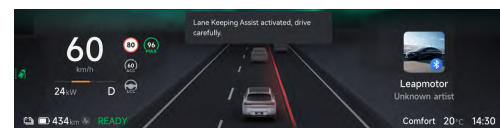

When the lane departure warning function is on, and the vehicle is traveling at a speed of not less than 60 km/h (37 mile/h), if the driver has not turned on the turn signal, and the system detects that the vehicle involuntarily deviates from the lane and crosses the line, the lane departure warning function is triggered. The instrument cluster displays the vehicle crossing line status and prompts the driver to maintain the original lane through a warning sound.

## FUNCTIONAL LIMITATIONS

Do not use the lane departure warning system in the following situations:

- At road intersections, merging points, etc.
- When using tire anti-skid chains.
- When tires have excessive wear and tire pressure is too low.
- When mixing tires of different construction, manufacturer, brand, or tread pattern.
- Vehicles are driving on the road under construction (e.g., construction signs, cones, and other barricades).
- On roads with sharp turns, steep slopes, icy or slippery surfaces, or in rain, snow, fog, and other weather conditions.

The following conditions may cause the lane departure warning system to not function as intended or to quit, including but not limited to:

- Through curves with excessive curvature, such as high-speed ramps.
- Lane lines that are unclear, worn, missing, crossed, or obscured by other vehicles or shadows cast by buildings or landscapes, etc.
- Passing through sections without lane lines, such as non-standard roads, intersections, and construction areas.
- Passing through sections with special lane lines, such as speed reduction markings, guide lines, etc.
- Passing through areas where lane markings are unclear, such as where lane lines merge or split, highway ramp entrances, urban intersections, left-turn waiting areas, etc.
- There are edges or other high-contrast lines on the pavement, rather than lane lines, such as pavement joints, curbs, etc.
- Lane lines cannot be recognized or are recognized incorrectly due to changes in elevation, such as on uphill and downhill slopes.
- Lane lines cannot be recognized or are recognized incorrectly due to lighting conditions, such as reflections of lane lines

caused by strong light, poor visibility due to bad weather, nighttime, or insufficient lighting.

- The distance between the lane lines on both sides is either too wide or too narrow.

The use of the lane departure warning system is not recommended under special or complex road conditions, which may cause the lane departure warning system to malfunction or exit, including but not limited to:

- Waterlogged, muddy, pothole-ridden, icy or snowy road surfaces, roads with speed bumps, and roads with obstacles.
- Traffic conditions with many pedestrians, bicycles, or animals.
- Complex and variable traffic conditions, such as busy intersections, highway ramps, congested roads, and so on.
- Winding roads and roads with sharp turns.
- Uphill and downhill roads.
- Rough roads.
- Narrow road.
- Tunnel entrance and exit.
- Roads without a central divider.

The above warnings and restrictions do not cover all possible conditions that may interfere with lane departure warning (LDW). There are a number of factors that can cause lane departure warning (LDW) to fail. To avoid a collision, you need to stay alert when driving your vehicle and always pay attention to road conditions so that you can anticipate whether corrective action needs to be taken early.

### WARNING

- The lane departure warning function is only an auxiliary system and cannot actively control the vehicle to change lanes or maintain the lane. The driver should always pay attention to road conditions, actively control the vehicle, and bear full responsibility for the safety of the vehicle.
- The lane departure warning system does not always recognize the lane lines. Due to factors such as bad weather, it may result in missed or false triggering of functions. Therefore, drivers must concentrate on observing the road and traffic conditions and drive carefully.
- Do not place objects that reflect light on the instrument panel, as they not only tend to dazzle the driver, but may also reflect light

into the system's front camera and interfere with the system's proper operation.

- Sound from the audio system inside the vehicle or noise from outside the vehicle may prevent you from hearing the warning beeps, so try to avoid disturbances and concentrate on the road conditions.
- Drivers should not rely too heavily on lane departure assist, nor intentionally test or wait for the function to trigger. False triggers and missed triggers cannot be completely avoided due to the inherent limitations of system performance.
- If the driver turns on the turn signal and makes a lane change in the direction of the turn signal, the lane departure warning function will be suppressed.
- The lane departure warning function may be suppressed when driving on steep slopes or curved roads, when the distance to the vehicle in front is too close, or when the vehicle in front obscures the lane line.
- The lane departure warning function may be suppressed when the vehicle experiences large bumps due to road conditions, during rapid acceleration or deceleration, or when quickly turning the steering wheel.
- Cracked front windshield, tinting, addition of non-compliant coatings, placement of light-reflecting items on the instrument panel, and any extraneous items that interfere with the camera's view may affect the proper functioning of the system.
- For your driving safety, do not test the lane departure warning function yourself. The camera field of view cannot be obstructed by objects or interfered with by strong light. If the field of view is temporarily blocked or interfered with by strong light, the function will temporarily exit and automatically resume once the field of view is restored. If the function cannot recover, contact the authorized dealer for help.
- The lane departure assist system will issue a warning when it detects an unconscious departure from the lane; do not panic or steer sharply without necessity.
- When the camera recognizes obstacles, it may cause the lane departure warning system to not function as intended or to exit. For camera limitations, see the "Advanced Driver Assistance Systems (ADAS) - Radar and Cameras" section.

## LANE KEEPING ASSIST (LKA)

### SYSTEM INTRODUCTION

The lane keeping assist system, abbreviated as "LKA", monitors and identifies the lane lines on the road surface in real time, collects data from the road ahead, and combines the vehicle's own driving data. When the system detects that the vehicle has a non-active tendency to deviate to the adjacent lane or is about to cross the lane line without the driver turning on the turn signal, the lane keeping assist system will apply a slight steering assistance to the steering wheel to reduce the possibility of the vehicle deviating from the lane.

### ACTIVATE LANE KEEPING ASSIST SYSTEM

After turning on the Lane Departure Warning and Assist function in the "Settings - Smart Driving - Active Safety" interface of the infotainment screen, select "Hold" or "Alert+Hold" to enable the lane keeping assist function.

### TRIGGER LANE KEEPING ASSIST SYSTEM



When the lane keeping assist is activated and the vehicle is traveling at a speed of not less than 60km/h (37mile/h), if the driver does not turn on the turn signal and the system detects that the vehicle has a non-active tendency to deviate to the adjacent lane or is about to cross the lane line, the lane keeping assist will be triggered. The system will apply slight deviation correction steering assistance to the steering wheel, and the instrument cluster will display the vehicle's lane-pressing status. If the vehicle deviates too much from the lane, the lane keeping assist will provide appropriate visual and audible alerts.

### FUNCTIONAL LIMITATIONS

Lane keeping assist (LKA) may experience functional failure or unintended functional effects in the following scenarios:

- Conditions such as large shadows in the lane, visible standing water, snow, construction, and other situations that may cause lane lines to be difficult to recognize may result in unstable or failed recognition of the lane lines, which may lead to the vehicle drifting out of the lane, failure of the lane keeping assist (LKA) function, and abnormal exit of the lane keeping assist (LKA) system.
- Visible standing water, snow, thin ice, spilled materials, obstacles, slippery road surfaces, sunken road surfaces, and other conditions that may cause wheel slip or severe bumps within the lane may cause the vehicle's traveling angle to deviate from the intended planned path when the lane keeping assist (LKA) intervenes, and in extreme cases, wheel slip may occur, affecting driving safety.
- Poor road lighting conditions and backlighting in the driving direction may lead to unstable or unidentifiable lane line recognition, which in turn may cause the vehicle to drift out of the lane, lane keeping assist (LKA) function to fail, and lane keeping assist (LKA) system to exit abnormally.
- In rain, snow, fog, and other weather conditions that may cause lane lines to be unrecognized, there are issues such as unstable or unrecognized lane line recognition, which may in turn cause the vehicle to deviate from the lane, the lane keeping assist (LKA) function to fail, and the lane keeping assist (LKA) system to exit abnormally.
- In strong windy weather, there are problems such as the vehicle traveling angle deviating from the expected planned path when the lane keeping assist (LKA) function intervenes, the vehicle deviating from the lane, and the lane keeping assist (LKA) function failing.

The above warnings and restrictions do not cover all possible conditions that may interfere with lane keeping assist (LKA). There are multiple factors that can cause lane keeping assist (LKA) to malfunction. To avoid a collision, you need to stay alert while driving your vehicle and pay attention to road conditions so that you can anticipate whether corrective action needs to be taken early.

#### WARNING

- Lane keeping assist is only an auxiliary system and does not replace the driver in monitoring traffic status; the driver should always focus on the road conditions, be in active control of the vehicle, and take full responsibility for the safety of the vehicle.
- Drivers should always keep their hands on the steering wheel and actively control the vehicle.
- The lane keeping assist system does not always recognize lane lines. Due to factors such as bad weather, the function may experience missed activation or false activation, so the driver must concentrate on observing the road and traffic conditions and drive cautiously.
- Lane keeping assist has limited steering force and provides only slight deviation correction steering assistance, and cannot guarantee that the vehicle will be completely prevented from drifting out of its lane, so do not rely on lane keeping assist for directional control, and the driver should always be prepared to increase steering effort, especially in curves.
- Lane keeping assist does not continuously control the direction of the vehicle, i.e. it does not keep the vehicle in the center of the lane at all times.
- Do not place objects that reflect light on the instrument panel, as they not only tend to dazzle the driver, but may also reflect light into the system's front camera and interfere with the system's proper operation.
- Drivers should not rely too heavily on the lane keeping assist system and should not intentionally test or wait for the function to trigger. False triggers and missed triggers cannot be completely avoided due to the inherent limitations of system performance.
- When the lane keeping assist system unexpectedly exits, such as in conditions of excessive curves, sloping road surfaces, unclear lane lines, or lanes that are too wide or too narrow, the system will only prompt the user of the function exit through a change in the lane line status in the instrument cluster. The driver must take full responsibility for driving safety.
- The lane centering control does not always recognize marking lines and may sometimes mistake poor road surfaces, certain road structures, or objects for lane lines. When this occurs, it is important to turn off the lane centering control immediately.
- Excessive tire wear or low tire pressure can degrade the performance of the lane centering control.
- The system may not provide a separate prompt when the function exits due to lane

departure while driving on a curve, so drive with caution.

- When the lane line has a non-smooth transition, the steering wheel may require large adjustments. Please drive with caution.
- When the road marking line and the road edge are close to each other, if the road marking line is not clear, such as the border lane inside a tunnel, the camera's recognition may switch between the lane line and the road edge, causing the steering wheel to swing back and forth. Please drive with caution.

## FORWARD COLLISION WARNING (FCW)

### SYSTEM INTRODUCTION

The forward collision warning system, abbreviated as "FCW," detects the relative distance, bearing, and speed between the front vehicle in the same lane and the vehicle, integrates the driver's other operational behaviors (e.g., stepping on the brake pedal, stepping on the accelerator pedal, etc.), evaluates the degree of pre-collision risk, and warns the driver when necessary, so that the driver is alerted to take measures to avoid or mitigate collision in time when there is a danger of collision.

### ENABLE OR DISABLE FORWARD COLLISION WARNING SYSTEM (FCW)

In the "Settings - Smart Driving - Active Safety" interface of the infotainment screen, tap the forward collision warning (FCW) button to turn on or off the forward collision warning system (FCW). When the system is turned on, the sensitivity of the forward collision warning distance can be adjusted:

- Low: Low safety distance sensitivity when the function is triggered.
- Medium: Medium safety distance sensitivity when the function is triggered.
- High: High safety distance sensitivity when the function is triggered.

## TRIGGER FORWARD COLLISION WARNING SYSTEM (FCW)



When the vehicle is moving, if the system detects a collision danger between your vehicle and the target vehicle in front, it will remind the driver to keep a safe distance through the instrument cluster. If the brake pedal is pressed during the alarm, the alarm stops.

The effective speed range of vehicles for automobiles is 8-150km/h (5-93mile/h), and the effective speed range for pedestrians, bicycles, and motorcycles is 8-90km/h (5-56mile/h).

### FUNCTIONAL LIMITATIONS

Only vehicles, cyclists, and pedestrians traveling in the same direction that meet the conditions will trigger the forward collision warning system. The following targets will not be responded to, including but not limited to:

- Oncoming vehicles.
- Side crossing vehicles.
- Animals.
- Traffic lights.
- Walls.
- Roadblocks (traffic cones, etc.).
- Other non-vehicle entities.

To optimize this function, the system needs to recognize the pedestrian's body contour and main features as clearly and completely as possible, that is, the pedestrian's head, shoulders, arms, legs, upper body, and lower body can be identified by combining standard human movement patterns. The following conditions may result in pedestrians not being recognized, preventing the forward collision warning system from functioning as intended. Including but not limited to:

- Pedestrians taller than 200cm or shorter than 100cm.
- Pedestrians wearing larger clothing (such as raincoats, hanfu, etc.) cause major features (arms, legs, etc.) to be obscured, making the contours unclear.
- Pedestrians first appear at a closer distance in the sensor's field of view.
- Pedestrians carrying large luggage or large backpacks.

- The color of clothes worn by the pedestrians has low contrast with the background color of the scene.
- Pedestrians holding umbrellas cause obstruction of the head, arms, and other main features.
- Pedestrians bending over or crouching.
- Pedestrian sitting in a wheelchair.
- The distance between pedestrians is relatively close.
- Pedestrians wear clothing with reflective materials.
- Pedestrians on roads at night, inside tunnels, and other dark places.
- There is a large variation in pedestrian speed when crossing.

To optimize this function, the system needs to recognize as clear and complete a body outline of the rider, key features, and the outline of the bicycle as possible. This function is intended for adult riders and for bicycles designed for adults. The following conditions may result in a cyclist not being recognized, preventing the forward collision warning system from functioning as intended.

Including but not limited to:

- When the features of a person or bicycle are obscured by clothing or other items, resulting in an indistinct outline.
- When the bicycle carries larger baggage or cargo.
- When the bicycle is moving fast.
- When the color and background contrast of cyclists and bicycles is low.
- When the cyclist's speed changes significantly.
- Cyclists first appear at a closer distance in the sensor's field of view.
- When riding on roads at night, inside tunnels, and other dark places.
- Use of hoverboards, kick scooters, scooters, special forms of electric bicycles, etc.

The following situations may cause the forward collision warning system to not operate as expected because the target is not ahead.

Including but not limited to:

- It will not respond to targets located in the sensor blind spot, such as targets in the vehicle corner blind spot and targets in the vehicle's side and rear blind spots.
- Targets may be mis-selected or missed when approaching or turning at roads.
- When on a slope, targets may be lost or the distance to the target may be misjudged.
- It may not be able to timely recognize when only part of the body of a vehicle in the adjacent lane

cuts into the front of your vehicle (especially large vehicles such as buses or trucks).

- It may not be able to timely recognize when your vehicle suddenly cuts in behind the vehicle ahead, or when another vehicle suddenly cuts in or out in front of your vehicle.

The following conditions may affect the forward collision warning system from functioning as intended due to unusual or complex road conditions. Including but not limited to:

- Waterlogged, muddy, pothole-ridden, icy or snowy road surfaces, roads with speed bumps, and roads with obstacles.
- Traffic conditions with many pedestrians, bicycles, electric bikes, or animals.
- Complex and variable traffic conditions, such as busy intersections, highway ramps, congested roads, and so on.
- Winding roads and roads with sharp turns.
- Uphill and downhill roads.
- Rough roads.
- Tunnel entrance and exit.

The following operations may cause the forward collision warning system not to issue an alarm.

Including but not limited to:

- The forward collision warning system may not issue an alarm when the driver is already braking.
- The forward collision warning system may not issue an alarm when the driver presses the accelerator pedal deeply or sharply.
- The forward collision warning system may not issue an alarm when the driver steers hard.

#### WARNING

- The forward collision warning system is an auxiliary function that cannot work in all driving situations, traffic, weather, and road conditions, and is not a substitute for focused driving and accurate judgment. The driver bears all responsibilities for driving safety.
- Always observe road conditions when driving and do not rely on the forward collision warning system to warn of or avoid a possible collision. Many factors can degrade or affect its performance, resulting in unnecessary, ineffective, or inaccurate warnings, brake interventions, or omissions. Relying on the forward collision warning system to warn of potential collisions and avoid them could result in serious personal injury or death.

- The forward collision warning system cannot guarantee the identification of special vehicles in all situations, especially at night when extra caution is required. For example: tricycles, vehicles with damaged tail lamps or unclear tail contours, vehicles with obstructed tails, vehicles with irregular shapes, vehicles with vertical rear surfaces below a certain height, unloaded vehicle-carrying vehicles, etc.
- The forward collision warning system may miss detecting vehicles that are stationary or moving slowly, especially at night when extra caution is required.
- The forward collision warning system can be triggered inadvertently when the vehicle needs to be driven into special scenarios such as onto a car carrier or a wrecker.
- Before driving the vehicle, be sure to confirm that there are no low obstacles around the vehicle that affect safety, to avoid incidents caused by obstructed vision.
- When the forward collision warning system is triggered, the driver must immediately apply the brakes to reduce speed or avoid obstacles according to the traffic situation.
- Forward collision warning only applies to warning of frontal collisions and will not work when the vehicle is in reverse gear.
- The monitoring range of the camera and radar sensors associated with the forward collision warning system is limited. Road and weather conditions may adversely affect the area that can be monitored by the forward collision warning system, so be sure to drive with caution.
- The forward collision warning system may issue an early warning when there is no risk of a collision. Stay focused and always keep an eye on the area in front of the vehicle in order to anticipate if any action needs to be taken.
- If traffic conditions or external influences cause the camera and radar to fail to correctly detect pedestrians, cyclists, vehicles, or other objects, warnings may be delayed or not given at all.
- When the camera and radar sensors recognize obstacles, it may cause the forward collision warning system to not function as intended. For camera limitations, see the "Advanced Driver Assistance Systems (ADAS) - Radar and Cameras" section.

## REAR COLLISION WARNING (RCW)

### SYSTEM INTRODUCTION

The rear collision warning system, abbreviated as "RCW," can monitor the environment behind the vehicle in real time while the vehicle is traveling and issue a warning message when a possible rear collision risk occurs.

### ENABLE OR DISABLE REAR COLLISION WARNING SYSTEM

In the "Settings - Smart Driving - Active Safety" interface of the infotainment screen, tap the rear collision warning button to turn on or off the rear collision warning function.

### TRIGGER REAR COLLISION WARNING SYSTEM



When the vehicle is traveling within the speed range of 15~150km/h (9~93mile/h), the instrument cluster sends out an alarm message to remind the vehicle behind to slow down or keep a safe distance from your vehicle by lighting up the hazard warning lamp when it monitors a vehicle approaching the vehicle quickly and there is a risk of being rear-ended.

### FUNCTIONAL LIMITATIONS

When there are no vehicles in the detection area, the system may still issue an alarm; false alarms may occur in the following cases:

- In a parking lot.
- On uneven road surfaces.
- In building area.
- Shrubs and trees.

In some cases, the rear collision warning system may struggle to provide assistance, which could include:

- The car behind changes lanes at the last moment.
- Detection of oncoming vehicles from behind is too late in scenarios such as sharp curves and ramps.

**▲ WARNING**

- The rear collision warning system is an auxiliary function that detects objects behind the vehicle through radar but cannot accurately detect all approaching targets. The driver should always remain attentive and observe the environment behind the vehicle while driving to avoid rear-end collisions and is fully responsible for the safety of the vehicle.
- The rear collision warning system cannot detect objects behind it through other vehicles or obstacles.
- When the vehicle behind is moving too fast, the function may not be able to issue an alarm in time.

**BLIND SPOT WARNING (BSW)****SYSTEM INTRODUCTION**

Blind spot warning system, abbreviated as "BSD", continuously detects the blind spot at the rear of the vehicle when it is moving forward. When other vehicles are detected entering the blind spot range, the system will provide an alert through warning indicators on the vehicle's rearview mirrors on both sides.

**ENABLE OR DISABLE BLIND SPOT WARNING SYSTEM**

In the "Settings - Smart Driving - Active Safety" interface of the infotainment screen, tap the blind spot warning button to turn on or off the blind spot warning system.

**TRIGGER BLIND SPOT WARNING SYSTEM**

When the vehicle is moving forward at a speed of not less than 10km/h (6mile/h), the system alerts the driver by lighting up or flashing the blind spot detection indicator on the rearview mirror when it detects that another vehicle has entered within the blind spot, avoiding incidents during driving.

**FUNCTIONAL LIMITATIONS**

The system may also sound an alarm when there is no vehicle in the blind spot, and the system may issue a false alarm in the following cases:

- Road guardrails.
- Highway concrete wall.
- In building area.
- Sharp turns around buildings.
- Shrubs and trees.
- Turning or vehicle U-turn.

In some cases, the system will have difficulty providing assistance to the driver, and the detection system may be affected or delayed.

Possible scenarios include, but are not limited to:

- The car behind changes lanes at the last moment.
- Detection of oncoming vehicles from behind is too late in scenarios such as sharp curves and ramps.
- The target car is obscured.
- The radar cross-section of the target vehicle is too small (may be a bicycle, an electric vehicle, etc.).
- The curve radius is too small or when entering and exiting the curve.
- Inclement weather, such as rain, snow.

**▲ WARNING**

- The blind spot warning system can only assist the driver in detecting vehicles traveling in the left and right blind spots, and the driver needs to pay attention to the vehicle's movement at all times; otherwise, there may be a safety hazard.
- If the blind spot warning system has a fault, stop the vehicle safely and contact the authorized dealer.
- The blind spot warning (BSW) system may have a delay, and the driver needs to be aware of the vehicle's movement at all times.
- The blind spot warning system assists the driver in monitoring the left and right rearview mirror blind spots, but does not replace the driver's subjective observation

and judgment. The driver must always maintain control of the vehicle and drive it properly, and bear full responsibility for the vehicle.

- The blind spot warning system may not provide adequate warning when a target vehicle is approaching the vehicle from the rear at a very fast speed.
- The blind spot warning system will issue a warning if unrelated targets at the side or rear, such as a large roadside barrier during road construction, a large billboard on the side of the road, a reflective panel in a tunnel, or other objects with a large reflective cross-sectional area, is incorrectly selected as the detected vehicle.
- Detection may be affected or delayed in certain environments. If the radar cross-section of the target vehicle is too small (it may be a bicycle, electric vehicle, pedestrian, etc.), the system risks failing to recognize the target, which can lead to false alarms. In addition, system detection may be affected by noise or electromagnetic wave interference, resulting in delays or disturbances.

## REAR CROSS TRAFFIC ALERT (RCTA)

### SYSTEM INTRODUCTION

The rear cross traffic alert system, abbreviated as "RCTA", detects other vehicles driving in the blind spot behind your vehicle when reversing. If the system determines that a vehicle gradually approaching from the rear may collide with your vehicle, it will issue audible and visual alarms to remind the driver to pay attention to reversing safety.

### ENABLE OR DISABLE REAR CROSS TRAFFIC ALERT SYSTEM

In the "Settings - Smart Driving - Active Safety" interface of the infotainment screen, tap the rear cross traffic alert button to turn on or off the rear cross traffic alert system.

## TRIGGER REAR CROSS TRAFFIC ALERT SYSTEM



When the vehicle is reversing and the system detects oncoming vehicles on both sides at the rear, the system will alert the driver by illuminating or flashing the blind spot detection indicator on the rearview mirror.

### FUNCTIONAL LIMITATIONS

The rear cross traffic alert system is unable to detect vehicles behind it through obstacles or parked vehicles. The oncoming vehicle warning system cannot detect vehicles crossing laterally from the rear in the following situations, including but not limited to:

- Stop at the innermost position.
- Parking spaces are at a certain angle.

The system may also sound an alarm when there is no vehicle in the detection area. The system may sound a false alarm in the following situations:

- Road guardrails.
- Highway concrete wall.
- In building area.
- Sharp turns around buildings.
- Shrubs and trees.
- Too close to the vehicles behind when parking.
- Indoor parking area.

### **⚠ WARNING**

- The rear cross traffic alert system is an auxiliary function that detects objects behind the vehicle through radar but cannot accurately detect all approaching targets. The driver should always remain attentive and observe the environment behind the vehicle when reversing to avoid collisions with other vehicles or pedestrians, and is fully responsible for safety during reversing.

## REAR CROSS TRAFFIC BRAKING (RCTB)

### SYSTEM INTRODUCTION

The rear cross traffic braking system, abbreviated as "RCTB", assists in braking when a vehicle is reversing at a low speed and is about to collide with a vehicle traveling laterally from behind, thereby minimizing the extent of the collision as much as possible.

The rear cross traffic braking system requires a target speed of no greater than 80km/h (50mile/h).

### ENABLE OR DISABLE REAR CROSS TRAFFIC BRAKING SYSTEM

On the "Settings - Smart Driving - Active Safety" interface of the infotainment screen, after the rear cross traffic alert function is enabled, tap the "Warning + Brake" button to turn on the rear cross traffic braking function.

### FUNCTIONAL LIMITATIONS

The rear cross traffic braking function is a driver assistance function that cannot handle all traffic, weather and road conditions.

When encountering (but not limited to) the following scenarios, the rear cross traffic braking function will not be able to assist in applying the brakes, or will stop continuing to apply the brakes while the brakes are being applied:

- The driver's seat belt is unfastened.
- Any door or the frunk/trunk of the vehicle is not closed or has a fault.
- The driver sharply turns the steering wheel, or the vehicle is at risk of lateral instability (e.g. excessive steering wheel angle or speed).
- The driver presses the accelerator pedal hard.
- The driver presses the brake pedal hard and releases it.
- Poor visibility (such as rain, snow, foggy weather, etc.).
- Poor road conditions (such as wet and slippery surfaces).
- Sharp curves.
- Vehicle brake system is faulty.

When encountering (but not limited to) the following scenarios, the system may miss, misdetect, or fail to detect an obstacle timely due to various factors such as rear/side rear

obstruction, target type, location, timing of appearance, etc., causing the system not to warn and brake or not to warn and brake in time:

- Poor weather conditions, such as rain, snow, fog, etc.
- There is a large vehicle behind/to the side of the vehicle that obscures the vehicle's radar or camera detection area.
- Obstacle recognition is unclear, inaccurate, or incomplete due to obstruction at the rear/side rear of the vehicle, or due to an obstacle that does not have a strong contrast in lighting with the visual environment in front.
- Pedestrians/two-wheelers carrying bulky objects are present at the rear/side rear of your vehicle.
- There are pedestrians or two-wheelers moving slowly into your lane at the rear or side rear of your vehicle, or moving towards your vehicle in the opposite direction.
- Your vehicle or the rear/side rear target is in a curve.
- There are targets at the rear/side rear of your vehicle that can only be detected after your vehicle changes lanes.
- Other situations that exceed the detection conditions and range of your vehicle's radar or camera.

When encountering (but not limited to) the following scenarios, the system may not be able to brake timely due to slippery roads, the target vehicle speed being too fast or too slow, or sudden braking by the target vehicle:

- Poor road conditions, such as slippery roads after sprinkler operation or rain.
- There are vehicles that quickly merge into your lane or cut into the rear of your vehicle at close range.
- The difference in relative speed between your vehicle and a vehicle traveling laterally from behind is relatively large.
- The vehicle traveling sideways from behind suddenly brakes.
- The vehicle is overloaded.
- The vehicle is on an uphill, downhill, or sharp curve.
- Other situations that affect or degrade the vehicle performance.

In scenarios with poor lighting such as strong light, reflections, etc., the system may misdetect or even misbrake. For example, the system may misdetect railroad tracks, gantries, height limiting poles, traffic signs, reflective ground studs, etc. as obstacles, thereby triggering anti-collision braking.

The anti-collision braking function will not be activated frequently; within several seconds after the previous anti-collision braking activation, the system will not trigger the anti-collision braking again.

### **▲ WARNING**

- The rear cross traffic braking function is a driver assistance function that is triggered when all conditions such as vehicle speed, driving environment, and obstacle conditions are met. It cannot detect vehicles, cyclists, or pedestrians in all situations and may be ineffective, inappropriate, or untimely due to a number of factors such as the your vehicle speed, type of obstacle, distance to the obstacle, the driving environment, and the system's response delay. Drivers should always pay attention to the traffic conditions and road environment, and never rely on the rear cross traffic braking function to reduce speed, avoid collision, or minimize the impact of a collision, and never substitute this for the driver's normal braking operation.
  - Due to the performance limitations of the system, rear cross traffic braking may be triggered inadvertently, resulting in sudden braking of the vehicle while in motion. The driver should always be alert to the surrounding environment and keep their hands on the steering wheel at all times while in use, so that they can take control of the vehicle timely in the event of a potential hazard and take full responsibility for the vehicle safety.
  - When rear cross traffic braking occurs, the brake pedal moves down quickly on its own. Therefore, ensure that the brake pedal can be moved freely. For example: ensure that the driver's floor mat is properly secured and avoid placing objects under or over the driver's floor mat (including stacked floor mats) to prevent affecting the brake pedal's ability to move freely.
  - Upon rear cross traffic braking, the driver should take immediate actions to avoid other incidents or injuries caused by emergency braking. For example, in scenarios where there is a real risk of collision, the driver should promptly press the brake pedal to ensure braking; for unnecessary braking, the driver can interrupt the braking by quickly hitting the accelerator pedal or turning the steering wheel.
- Drivers should always remain vigilant, closely watch for various dangerous situations around them, and keep their hands on the steering wheel at all times so that they can promptly control the vehicle in the event of potential danger, ensuring safe driving. Violation of the above operations will affect your safe driving and may cause an incident or even lead to property damage, personal injury, or death.

## DOOR OPENING WARNING (DOW)

### SYSTEM INTRODUCTION

When the vehicle is stopped or traveling at low speeds, the door opening warning system detects vehicles approaching from behind in adjacent lanes and alerts the driver when there is a risk of opening the door.

### ENABLE OR DISABLE DOOR OPEN WARNING

In the "Settings - Smart Driving - Active Safety" interface of the infotainment screen, tap the door opening warning (DOW) button to turn on/off the door opening warning function.

### TRIGGER DOOR OPEN WARNING



When the vehicle is stationary, the system detects that another vehicle has entered the blind spot detection range. If the driver intends to open the door at this time, the system will remind the driver by lighting up or flashing the blind spot detection indicator on the rearview mirror.

## FUNCTIONAL LIMITATIONS

When there are no vehicles in the detection area, the system may still issue an alarm; false alarms may occur in the following cases:

- Road guardrails.
- Highway concrete wall.
- In building area.
- Shrubs and trees.
- Too close to the vehicles behind when parking.
- There is a larger vehicle behind your vehicle.
- Your vehicle or the rear target is in a bend.
- Rear vehicles quickly change lanes to move behind your vehicle.
- There are targets behind your vehicle that can only be detected when your vehicle changes lanes.

### WARNING

- Door opening warning is an auxiliary function that detects obstacles in the vehicle's blind spot through radar but cannot accurately detect all obstacles. Therefore, drivers should always remain attentive and observe the vehicle's surrounding environment when opening the door to ensure that the door will not collide with vehicles, pedestrians, etc., and bear full responsibility for door opening safety.

## IN-VEHICLE LIFE MONITORING SYSTEM\*

### SYSTEM INTRODUCTION

After the driver leaves the vehicle and locks it, the in-vehicle life monitoring system monitors whether any living beings are left inside the vehicle, and provides reminders and initiates active intervention measures when necessary to ensure the safety of the left-behind living beings.

### ACTIVATE OR DEACTIVATE IN-VEHICLE LIFE MONITORING SYSTEM

On the "Settings-System-Safety" interface of the infotainment screen, tap the Life Detection button to turn on or off the in-vehicle life monitoring system.

## FUNCTIONAL LIMITATIONS

The in-vehicle life monitoring system is designed to alert the user through sound, light, messages, etc., when the vehicle is locked and parked normally and the system detects that there is a living being left inside the vehicle. Hardware faults or network abnormalities will cause the system to fail.

### WARNING

- The in-vehicle life monitoring system is only an auxiliary system and cannot ensure effective identification and issue an alarm under all circumstances. It does not replace the driver's judgment and is not responsible for injuries or deaths suffered by passengers left in the vehicle. Please confirm the condition inside the vehicle before leaving.

## ADVANCED DRIVER ASSISTANCE SYSTEMS (ADAS)

### RADAR AND CAMERA CAMERA DISTRIBUTION

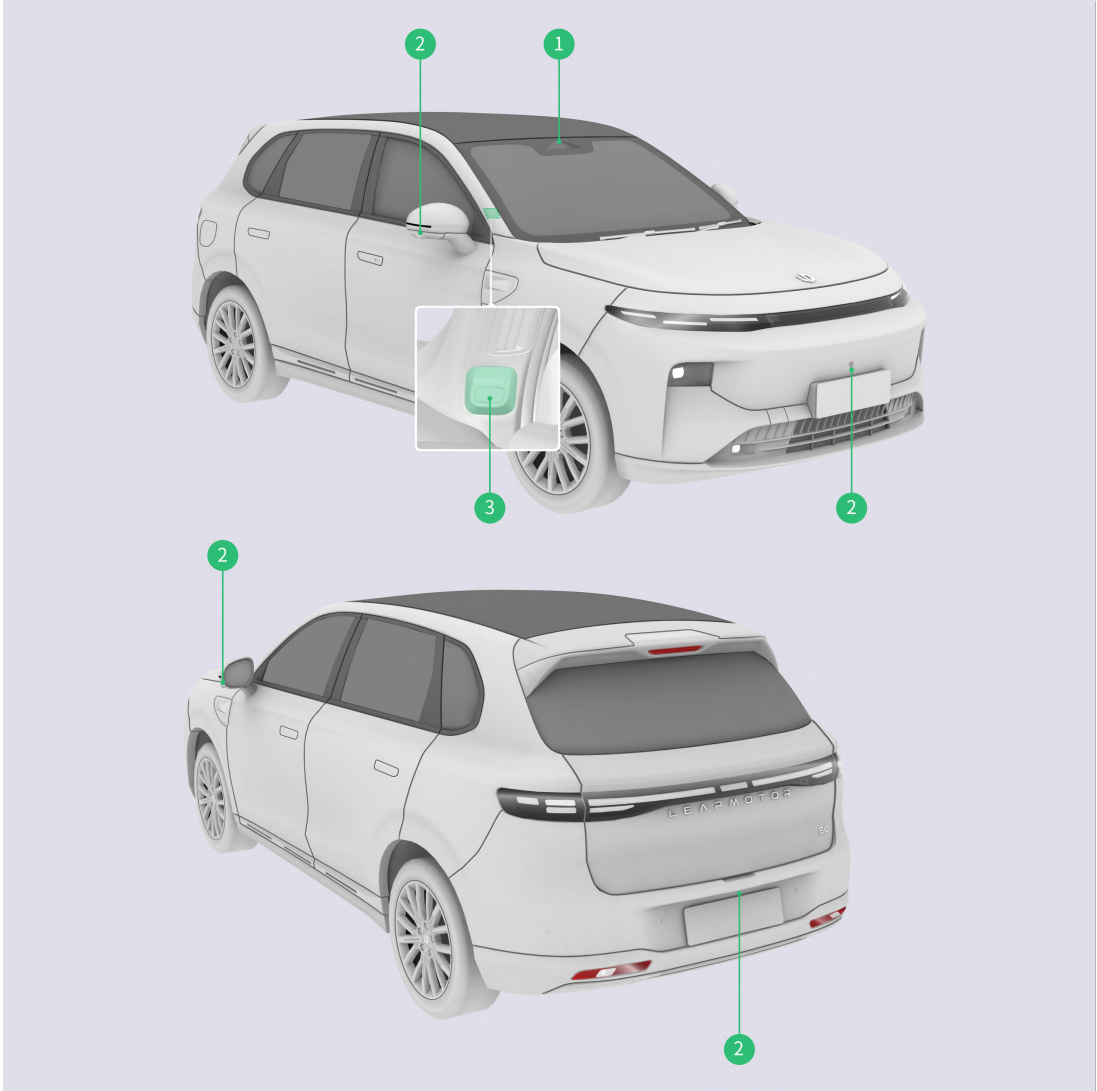

1. Front-view camera

2. AVM camera (fisheye)

3. Driver Drowsiness and Attention Warning (DDAW) camera

## RADAR DISTRIBUTION

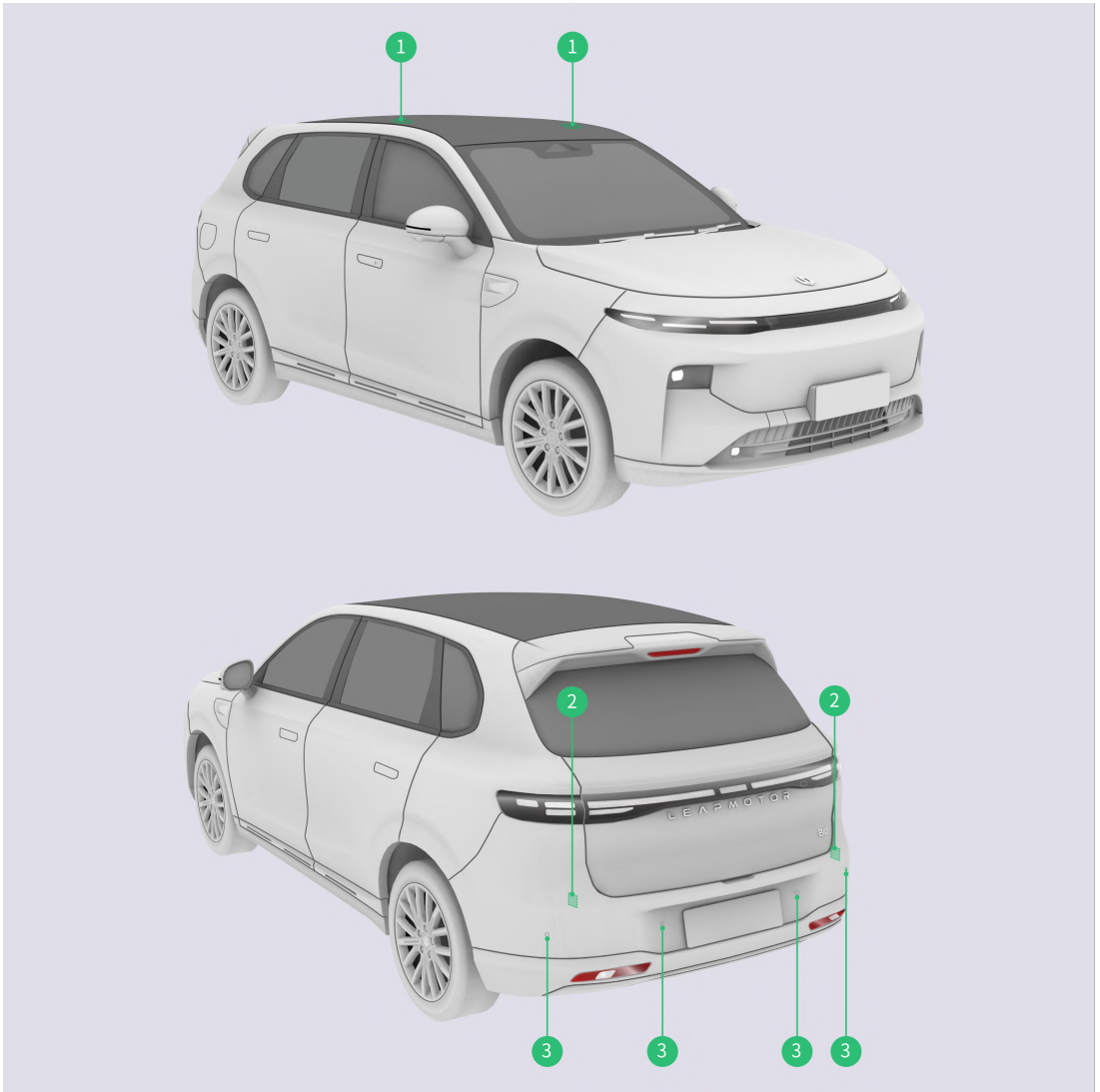

1. In-vehicle vital signs detection radar\*

2. Angular millimeter wave radar

3. Rear ultrasonic radar

### LIMITATIONS OF RADAR AND CAMERA

The following target radar/camera cannot recognize:

- Special vehicles, such as vehicles with covered rear ends, damaged vehicles, and vehicles with irregular shapes, etc.
- Encountering animals, traffic lights, walls, and other unknown obstacles in the road.
- Some metal guardrails, green belts, concrete walls, etc.
- Road test facilities, traffic cones, crash barrels, tripods, small construction signs, etc.
- Static obstacles, such as encountering road construction facilities on the road (traffic cones, crash barrels, traffic bollards, warning triangles, or other roadblocks).
- Static objects, such as low-speed or stationary sweepers, overturned vehicles, large rocks, tripods, isolation belts, and pedestrians crossing the road.
- Low obstacles, such as buckets, low boxes, etc.
- Overhanging obstacles, such as wall-suspended water pipes, and undercarriage overhang.
- Obstacles in the blind spot cannot be recognized.

The following situations can cause the radar/camera to fail to detect the target, experience recognition delays, or produce recognition errors:

- The radar or camera is blocked or dirty, such as being covered with foreign objects like ice, snow, frost, rain, fog, accumulated water, dust, etc.
- Radar, camera, or associated parts have a fault.
- Adverse weather, such as rain, snow, fog, etc.
- The vehicle shakes or jolts due to uneven roads or other reasons.
- There are sound wave sources of the same frequency interfering around the vehicle.
- There are objects near the vehicle that can cause false reflection of sound waves.
- The target detected by the radar is attached with materials that absorb sound waves, such as snowflakes, foam, cotton objects, etc.
- The detected object volume is too small.
- In very rare special cases, false alarms may be triggered by some metal guardrails, green belts, concrete walls, etc.
- When the brightness of the surrounding environment suddenly changes, such as at the entrance or exit of a tunnel.
- Large shadows cast by buildings, scenery, or large vehicles.

- The vehicle is involved in a collision, and the radar or camera mounting position is altered.
- Bright light, such as oncoming headlights or direct sunlight.
- Dim surroundings, such as night, dawn, dusk, tunnels, etc.

#### ATTENTION

- When rinsing the body with high-pressure water, try to avoid directly rinsing the radar and camera, so as not to affect the performance of the radar and camera. If there is water or dust on the radar and camera, use a soft damp cloth to wipe them clean in time.

### FULL-SPEED ADAPTIVE CRUISE CONTROL (ACC)

#### SYSTEM INTRODUCTION

Full-speed adaptive cruise control system, abbreviated as "ACC," allows the driver to set the cruise speed and following distance through the steering wheel buttons during normal driving. When the distance to the vehicle in front is too close, ACC controls the vehicle deceleration to maintain a safe distance from the vehicle ahead. Full-speed adaptive cruise control (ACC) only controls longitudinal acceleration and deceleration, not steering wheel control.

Full-speed adaptive cruise control is a comfortable assisted driving function. If the road ahead is clear, it will maintain the maximum set cruising speed and continue moving forward. If there is a vehicle in front, the speed will be reduced as necessary to maintain the set following distance from the vehicle ahead.

## ENABLE FULL-SPEED ADAPTIVE CRUISE CONTROL



When the vehicle is driving normally and the instrument cluster full-speed adaptive cruise control (ACC) available icon appears, push the column shift downward to activate full-speed adaptive cruise control (ACC). The instrument cluster will indicate that the function has been turned on; if full-speed adaptive cruise control (ACC) is unavailable, the instrument cluster will indicate that the function is not available.

Depress the accelerator pedal while pushing the column shift downward. If the current vehicle speed is greater than 30 km/h (19 mile/h), the cruise speed is set to the current vehicle speed; if the current vehicle speed is less than or equal to 30 km/h (19 mile/h), the cruise speed is set to 30 km/h (19 mile/h).

## STEERING WHEEL BUTTONS CONTROL FULL-SPEED ACC



Speed control:

- Scroll the wheel upward, and the speed will increase by 1 km/h for each notch.
- Scroll the wheel downward, and the speed will decrease by 1 km/h for each notch.

Following distance setting (3 levels in total):

- Each time the wheel is toggled to the left, the following distance is set one level closer.

- Each time the wheel is toggled to the right, the following distance is set one level farther.

## DISABLE FULL-SPEED ADAPTIVE CRUISE CONTROL

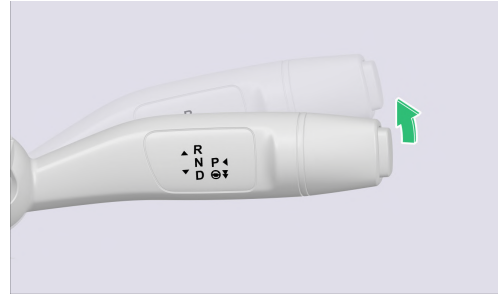

With full-speed ACC enabled, it can be turned off by pushing the column shift upward or pressing the brake pedal.

## FUNCTIONAL LIMITATIONS

Situations where the full-speed ACC function is not available:

- Full-speed adaptive cruise control (ACC) system fault.
- The vehicle is not in D gear.
- Vehicle speed is 0.
- The turning radius of road curve is too small.
- The vehicle doors are not closed.
- Press down on the brake pedal.
- Brake fluid alarm.
- Electronic parking brake (EPB) not released.
- Accelerator pedal opening greater than 65%.
- Vehicle rolling backward.
- In overly dark environments such as at night, basements, tunnels, and bridge underpasses, as well as in severe weather conditions such as heavy rain, heavy snow, and heavy fog.

### **▲ WARNING**

- Full-speed adaptive cruise control (ACC) system is not a safety system, an obstacle detector, or a collision warning system, but rather a comfort system. The driver must always maintain control of the vehicle, observe the road conditions ahead, and take corrective actions at any time. Do not rely on the system and be fully responsible for the driving safety of the vehicle.

- Full-speed adaptive cruise control (ACC) is an assisted driving function that does not cover all road scenarios, weather, and complex road conditions. The driver must use ACC with caution based on the weather conditions, road traffic conditions, and visibility, and be fully responsible for the driving safety of the vehicle.
- Do not use the full-speed adaptive cruise control (ACC) function on winding roads with sharp curves, on icy or slippery surfaces, or in adverse weather conditions (such as heavy rain, heavy snow, dense fog, etc.) when driving at a constant speed is not advisable.
- When using the full-speed adaptive cruise control (ACC) function, the driver must always observe the road ahead and be prepared to take immediate corrective measures. If the distance to the vehicle in front is too close and the speed is significantly higher than that of the vehicle ahead, the braking effect of full-speed adaptive cruise control (ACC) cannot ensure safety. The driver should take timely measures to reduce the vehicle speed to avoid a collision.
- During driving, when a vehicle in an adjacent lane quickly moves laterally to the front of your vehicle or is just in front of your vehicle on an adjacent curve, it may cause full-speed adaptive cruise control (ACC) to misjudge the target. ACC may cause the vehicle to brake when braking is not needed or when the driver has not applied the brakes. The driver should always be alert to the surrounding environment and keep their hands on the steering wheel at all times, so that the vehicle can be controlled timely when there is a potential danger, ensuring driving safety.
- Full-speed ACC only enables limited braking, not emergency braking.
- At intersections, speed bumps, crossing crosswalks, changing lanes, highway entrances and exits, ramps, or construction sections, the driver should take control of the vehicle to exit full-speed adaptive cruise control (ACC) to ensure driving safety.
- While the vehicle is traveling, if another vehicle suddenly cuts in quickly or changes lanes to the front of your vehicle at close range, the full-speed adaptive cruise control (ACC) may not be able to brake or decelerate in time.
- The full-speed adaptive cruise control (ACC) system is suitable for driving on highways and roads with good conditions. Do not use full-speed adaptive cruise control (ACC) on city roads or in changing road conditions.
- Full-speed adaptive cruise control (ACC) may react to vehicles or objects that do not exist or are not in the driving lane, causing the vehicle to slow down unnecessarily or inappropriately. The driver should always keep their hands on the steering wheel and be ready to take control of the vehicle at all times. Do not rely on the full-speed adaptive cruise control (ACC) system.
- ACC can only control the vehicle speed, not its direction of travel.
- For stationary vehicles or objects, especially when the vehicle in front suddenly leaves the driving lane in which your vehicle is located and there is a stationary vehicle or object ahead in your lane, full-speed ACC cannot detect all objects and may not be able to brake/decelerate. Drivers must pay close attention to the road ahead when using ACC and be prepared to take corrective action quickly. Over-reliance on full-speed ACC may cause serious personal injury or even be life-threatening.
- When using full-speed ACC, the driver should always pay attention to the vehicle's surroundings and maintain a reasonable distance from the vehicle in front. When the vehicle in front cuts in quickly at close range or the relative speed is too small, the system does not have enough time to reduce the relative speed. In this situation, the driver must take timely measures to ensure driving safety.
- The full-speed adaptive cruise control (ACC) function may exit at any time for unknown reasons. When using this function, the driver must always observe the road ahead and be prepared to take appropriate measures. The driver is responsible for maintaining control of the vehicle at all times to ensure driving safety.
- The full-speed adaptive cruise control (ACC) system can control the vehicle to move out after a brief stop and driver confirmation (by lightly pressing the accelerator pedal). During this time, the driver must ensure that there are no obstacles or other traffic participants, such as pedestrians, directly in front of the vehicle.
- The calibration of the radar sensors and cameras may be affected by collision or vibration that degrades performance, in which case recalibration may be required.

- When entering and exiting corners, the selection of targets may be delayed or interfered with. In these situations, full-speed ACC vehicles may not brake as expected or brake too late.
- On sharp bends, such as serpentine roads, the vehicle ahead may disappear from view within a few seconds due to the limitations of the radar sensor and camera field of view. This could cause full-speed ACC vehicles to accelerate.
- When vehicles are traveling in road scenarios such as sharp curves, due to the limited recognition range of the system, it may result in the inability to recognize the vehicle in front or a significant lag in recognition.
- In some cases (such as when the relative speed of the vehicle ahead is too slow, lane changes are made too quickly, or the safety distance is too small), the system does not have enough time to reduce the relative speed. In this situation, the driver must react appropriately. The system cannot issue a sound or image warning in every situation.
- If the full-speed ACC vehicle is too close to the adjacent lane (or the vehicle in the adjacent lane is too close to the lane of the full-speed ACC vehicle), it is possible for the full-speed ACC to react to that vehicle and brake.
- If a vehicle changes lanes into the path of a vehicle using full-speed ACC and is within the radar detection range, it will be recognized as a target vehicle and reacted to as a target vehicle, which could potentially result in strong braking or late braking.
- Detection may be affected or delayed in certain environments. For example, when a target has a small radar cross-section (may be a bicycle, a four-wheeled carriage, or a pedestrian), the system risks being unable to confirm the distance to the vehicle in front, which may result in delayed or no response to such vehicles. In such cases, the driver needs to control the speed of vehicle. In addition, the detection may be affected by noise or electromagnetic interference, resulting in delays or interference.
- If the vehicle is driven for a long period of time in special road conditions such as circular parking lots, tunnels, etc., the radar may experience a short-term fault due to the limitations of the detection characteristics. At this time, the function can be restored to normal by restarting the vehicle or driving along a normal road for a certain distance.
- Structurally modified vehicles, such as those with a lowered chassis or altered front end license plate mounting plate, may affect the full-speed adaptive cruise control (ACC) system.
- Metal objects such as rails or metal plates used for road construction may interfere with the radar sensor, preventing it from functioning properly.
- Full-speed ACC may not provide adequate speed control due to limited braking ability and being on a hill. It may also misjudge the distance to the vehicle in front. Going downhill increases the vehicle's travel speed, which causes the vehicle to exceed the set speed (and possibly the road speed limit). Always observe the road conditions while driving and be prepared to take the correct measures as needed.
- For stationary or slow-moving objects, such as vehicles, the tail end of traffic, toll booths, bicycles, or pedestrians, full-speed adaptive cruise control (ACC) only responds under special conditions, which have a high degree of specificity.
- If the vehicle in front suddenly brakes (emergency stop), full-speed adaptive cruise control (ACC) will not be able to react or will react too slowly to the vehicle in front, resulting in late braking. In this situation, the driver will not receive a takeover request.
- You are responsible for determining and always maintaining a safe following distance; do not rely on full-speed adaptive cruise control (ACC) to maintain an accurate or suitable following distance or rely on full-speed adaptive cruise control (ACC) to sufficiently reduce the vehicle speed to avoid a collision. Always observe the road conditions ahead and be prepared to take immediate corrective actions.
- Do not use the full-speed adaptive cruise control (ACC) function in narrow scenes, pedestrian-vehicle traffic scenes, underground garages, interior parks, and other scenes.
- If you encounter unusual vehicles, toll booths, bicycles, or pedestrian crossing, pay close attention while driving, keep your hands on the steering wheel, and be ready to control the vehicle at all times.

**NOTE**

- The maximum set speed of full-speed ACC is 150 km/h (93 mile/h).
- The minimum set speed for full-speed ACC is 30km/h (19mile/h), but it can follow to a stop at 0km/h (0mile/h).

## LANE CENTERING CONTROL (LCC)

### SYSTEM INTRODUCTION

The lane centering control system, abbreviated as "LCC", assists the driver in controlling the steering wheel by recognizing the lane line and continuously centering the vehicle in the current lane. If it detects that the driver's hands are not on the steering wheel during driving, the system will issue an alarm based on factors such as weather, vehicle speed, and road environment, prompting the driver through sound and light signals to take timely control of the vehicle and drive safely.

### ENABLE OR DISABLE LANE CENTERING CONTROL FUNCTION

In the "Settings - Smart Driving - Assisted Driving" interface of the infotainment screen, tap the lane centering control button to turn on or off the lane centering function.

### TRIGGER LANE CENTERING FUNCTION



With the lane centering control (LCC) function available, the driver activates the lane centering control (LCC) function by pushing the column shift down twice consecutively. When the function is activated, the corresponding indicator on the instrument cluster lights up.

## STEERING WHEEL GRIP MONITORING

If the driver's hands leave the steering wheel while the lane centering control (LCC) function is active, the steering wheel grip monitoring alarm will be triggered.

- Steering wheel grip monitoring L1 warning: "Please turn the steering wheel gently" (always displayed), the steering wheel icon is gray.
- Steering wheel grip monitoring L2 warning: Display the alarm diagram, accompanied by an alarm sound.
- Steering wheel grip monitoring L3 warning: Display the alarm diagram, accompanied by an alarm sound.

## EXIT LANE CENTERING FUNCTION

The lane centering control (LCC) system will exit under the following conditions:

- The driver actively intervenes in the steering wheel.
- The driver pushes the column shift upwards.
- The driver hits the brake pedal.
- No lane lines for a long time.
- The angle between the vehicle and the lane line is too large.
- Lane width is either too wide or too narrow.
- Sharp curves.

## FUNCTIONAL LIMITATIONS

The lane centering control (LCC) system may have limited functionality and should not be used in the following situations:

- Roads with sharp turns, patchwork roads, or roads in poor condition, such as bumpy, slippery, waterlogged, or icy roads.
- On sloping roads, or on uphill and downhill sections.
- The lane is either too wide or too narrow.
- Roads where pedestrians or cyclists may appear.
- Darkness (poor lighting conditions) or poor visibility (caused by heavy rain, heavy snow, dense fog, etc.).
- When strong light (such as oncoming headlights or direct sunlight) obstructs the camera field of view.
- The vehicle ahead blocks the camera field of view or obscures the lane lines.
- Windshield blocks the camera field of view (water spray, dust, or sticker, etc.).

- Excessive wear or obstruction, covering, or disappearance of lane lines; temporary adjustments or rapid changes due to road construction (e.g., lane forks, crosses, or merges).
- Objects or landscape features cast shadows onto the lane.
- The road surface has text or traffic signs.
- Sections with diversion lines.
- Warning cones, warning signs, or other objects are placed on the road surface.
- Large vehicles such as trucks, buses, etc. are present to the side or in front of your vehicle.
- On the construction section.
- Radar or camera limited.
- Lane centering control (LCC) performance can be affected when there is a large lateral airflow or strong wind on one side of the vehicle, and this weather is not suitable for using the lane centering control (LCC) system.

#### WARNING

- The lane centering control (LCC) function cannot replace the driver's monitoring of traffic status. The driver should always be alert to the surrounding environment and keep their hands on the steering wheel while using it, so that they can take timely control of the vehicle in the event of potential hazards and bear full responsibility for the safety of the vehicle.
- Drivers should always keep their hands on the steering wheel and actively control the vehicle.
- The lane centering control (LCC) function cannot cover all traffic, weather, and road conditions, and should never be used in severe weather (such as rain, snow, or fog).
- The lane centering control (LCC) function has limited steering force and provides only slight deviation correction steering assistance, and cannot completely stop the vehicle from drifting out of its lane, so do not rely on the system to control your direction, and drivers should always keep their hands on the steering wheel to ensure safe driving.
- Do not place objects that reflect light on the instrument panel, as they not only tend to dazzle the driver, but may also reflect light into the system's front camera and interfere with the system's proper operation.
- Please be cautious when using lane centering control (LCC) on congested roads. The behavior of other vehicles (e.g., other vehicles cutting in front of your vehicle or crossing in front of your vehicle, vehicles leaving your lane, etc.) may interfere with LCC and cause incorrect steering, leading to scraping or even collisions between your vehicle and other vehicles. It is the driver's responsibility to intervene promptly and avoid collisions with other vehicles.
- Do not use lane centering control (LCC) on city roads or in changing road conditions.
- Do not use lane centering control (LCC) on twisty roads with sharp curves, bumpy, icy, or slippery surfaces; the lane centering control (LCC) system cannot stably assist steering wheel control under these poor road conditions.
- When the direction of the lane line ahead changes dramatically, such as lane merge, or a sudden increase or decrease in lane width, lane centering control (LCC) may fail. In these road scenarios, drivers should always be alert to their surroundings and keep their hands on the steering wheel at all times, so that they can timely control the vehicle in the event of a potential hazard to ensure driving safety.
- When using lane centering control (LCC) on curves, the driver must keep their hands on the steering wheel to control the vehicle, and take control of the vehicle promptly when lane centering control (LCC) exits.
- Do not use lane centering control (LCC) at road diversions.
- If a vehicle changes lanes rapidly at close range to the front of your vehicle, it may cause abnormal operation of lane centering control (LCC). The driver should always be alert to the surrounding environment and keep their hands on the steering wheel at all times, so that they can timely control the vehicle in the event of potential danger to ensure driving safety.
- Do not use lane centering control (LCC) when the vehicle is in poor condition, such as abnormal four-wheel alignment, abnormal tire pressure, etc.
- Lane centering control (LCC) may unexpectedly exit at any time for unknown reasons. The driver must observe the road ahead and be prepared to take appropriate measures, and the driver is responsible for always controlling the vehicle and bears full responsibility for the safety of the vehicle.

- Lane centering control (LCC) occasionally assists the vehicle in steering when steering assistance is not needed or when you do not intend to steer. This may be caused by unclear or irregular lane lines, or by other lines or objects on the lane surface that resemble lane lines. In this case, you should promptly take control of the vehicle.
- Lane centering control (LCC) may not function properly at traffic intersections and may perform unintended steering control causing unanticipated hazards, such as scratches or even collisions with other vehicles at the intersection. Therefore, do not use lane centering control (LCC) at traffic intersections.
- Guardrails, isolation belts, or curbs on one side of the road may interfere with the sensors and cause abnormal operation of the lane centering control (LCC). Drivers should always be alert to their surroundings and keep their hands on the steering wheel at all times, so that they can timely control the vehicle in the event of potential danger to ensure driving safety.
- In road sections where the lane lines are blurred, disappear, or are covered, if the vehicle ahead turns or a vehicle crosses in front of this vehicle, it may cause abnormal steering with lane centering control (LCC).
- When the lane line disappears or disconnects, the driver should take timely control of the vehicle to avoid unanticipated hazards caused by the failure or abnormality of lane centering control (LCC).

### NOTE

- The lane centering control (LCC) function can be activated within a speed range of 30 to 150 km/h (19 to 93 mile/h).

## EMERGENCY LANE KEEPING ASSIST (ELK)

### SYSTEM INTRODUCTION

The emergency lane keeping assist system is abbreviated as "ELK". When there is a risk of collision with an oncoming vehicle in an adjacent lane, the rear, or the road edge while the vehicle is in motion, the system will actively intervene with

steering wheel control to make corrections to avoid a collision. This process still requires the driver to focus on driving and always pay attention to the surrounding environment.

## ACTIVATE OR DEACTIVATE EMERGENCY LANE KEEPING ASSIST

In the "Settings – Smart Driving – Active Safety" interface of the infotainment screen, tap the "Emergency Lane Keeping Assist" button to turn on or off the emergency lane keeping assist function.

### NOTE

- Precautions associated with the emergency lane keeping assist (ELK) system are consistent with the lane centering control (LCC) system.

## INTELLIGENT SPEED ASSISTANCE (ISA)\*

### SYSTEM INTRODUCTION

Intelligent speed assistance, abbreviated as "ISA", displays the speed limit value on the instrument cluster when the system recognizes the road speed limit sign during driving. When the vehicle exceeds the current road speed limit, the system will send out an alarm message to remind the driver to slow down.

## ENABLE OR DISABLE INTELLIGENT SPEED ASSISTANCE FUNCTION

In the "Settings – Smart Driving – Assisted Driving" interface of the infotainment screen, tap the intelligent speed assistance button to turn on or off the intelligent speed assistance function. When the function is turned on, you can choose to enable or disable the speed limit change beep, overspeed alarm, overspeed alarm sound, and speed limit control.

## TRIGGER INTELLIGENT SPEED ASSISTANCE FUNCTION



The system can recognize road speed limit signs and display speed limit information to the driver while the vehicle is in motion.

- The system will provide a prompt when the speed limit changes.
- When the vehicle speed exceeds the speed limit value, the system will trigger overspeed flashing and audible alarm (the alarm sound can be turned off on the infotainment screen).
- When the adaptive cruise control function is active, the system recognizes the speed limit and performs speed control after driver confirmation.

### WARNING

- Intelligent speed assistance is only an auxiliary system and cannot completely replace the driver's judgment of road speed limit information. In any case, drivers should pay attention to road information signs, drive cautiously, and take full responsibility for vehicle safety.
- The intelligent speed assistance system can only recognize speed limit signs and provide reminders; it does not participate in the active control of the vehicle. The control of vehicle is always kept in the hands of the driver. Please drive reasonably.
- Do not rely on the intelligent speed assistance system to determine the appropriate speed limit or travel speed; always drive within a safe speed range based on traffic and road conditions.
- Cameras are not always accurate in recognizing speed limit signs. The system may misjudge road conditions and provide speed limits that happen to be different for adjacent roads, or the camera may misidentify and display speed limit signs incorrectly.
- For speed limit signs that are not standardized and do not meet the national size requirements, they may be misrecognized as speed limit signs, causing misrecognition.

- Speed limit signs that are unclear or distorted, tilted, reflective, partially obscured, or covered will result in reduced or no recognition by the camera.
- The performance of intelligent speed assistance is affected by weather, illumination, and the visual quality of road signs. Conditions such as night, backlight, sunset, rain, fog, haze, ice and snow cover, sand and dust, and sudden changes in brightness may all result in a reduced ability to recognize speed limit signs.

## DRIVER DROWSINESS AND ATTENTION WARNING SYSTEM (DDAW)

### SYSTEM INTRODUCTION

The driver drowsiness and attention warning system, abbreviated as "DDAW", mainly monitors the driver's fatigue state in real time through the detection of DDAW cameras and the auxiliary comprehensive judgment of some in-vehicle signals during normal vehicle operation, thereby achieving the fatigue early warning function. And through visual and audible reminders, it achieves the effect of warning drivers and correcting incorrect driving behavior.

### FUNCTION OPERATION

The driver drowsiness and attention warning system is turned on by default when the vehicle is started. When the vehicle is in D gear and the vehicle speed is not less than 10km/h (6mile/h), if the system detects that the driver is driving while fatigued, the vehicle will prompt the driver through a pop-up window on the infotainment screen and an instrument cluster icon , and warn the driver to drive safely through an alarm sound.

### FUNCTIONAL LIMITATIONS

In the following situations, the driver drowsiness and attention warning system may be affected:

- The camera is blocked.
- The camera is exposed to strong direct light.
- Driver's face is partially illuminated by light or facial features are incomplete.
- The driver wears a mask and infrared blocking glasses. Or other objects block the driver's mouth.

- The driver's sitting posture is abnormal and exceeds the range of conventional driving postures.
- Adjustment of the interior rearview mirror or steering wheel.
- Obstruction of the interior rearview mirror, including but not limited to dashcams, window tint, and stickers.

In some cases, behaviors that may affect or lead to the inability to detect driver drowsiness and distracted driving, resulting in the system not issuing corresponding warnings or being partially unavailable:

- Situations where direct light such as sunlight and oncoming vehicle headlights interferes.
- Abnormal sitting posture or beyond the range of conventional driving postures.
- Situations where the eyes are obstructed, including but not limited to various sunglasses with low light transmission, polarized lenses, sunglasses, and eyeglass frames causing obstruction.
- Hats, scarves, headscarves, and other accessories that may change the shape of the head.
- The driver wears a mask.



### ▲ WARNING

- The driver drowsiness and attention warning system is only an auxiliary system that cannot ensure effective recognition and issue an alert in all circumstances, and cannot replace the driver's subjective judgment. Do not rely on the system's alerts, the driver must always maintain control of the vehicle and drive normally, comply with road regulations, and take full responsibility for the vehicle.
- It is very important to focus on driving and to take breaks as needed. When the system issues a fatigue warning, drivers should promptly adjust their driving behavior or stop for a break as soon as possible in a safe manner.
- The driver drowsiness and attention warning system cannot actively intervene in driving operations; the driver always has the responsibility to drive the vehicle safely and cautiously.
- The driver drowsiness and attention warning system is an advanced driver assistance systems and cannot work properly under all conditions. You always have the responsibility

to drive the vehicle safely and carefully, and to comply with current laws and traffic regulations.

- Do not engage in drowsy driving. It is the driver's responsibility to maintain a healthy and alert driving status at all times.
- When the driver realizes drowsy driving, stop and rest as soon as possible.

### ▲ ATTENTION

- If there is a recoverable short-term fault of the system (e.g. camera obscured, etc.), the instrument indicator  illuminates. A text reminder on the infotainment screen informs the user that the system is currently faulty and the related fatigue detection function is disabled. After the fault is repaired, the driver drowsiness and attention warning system (DDAW) will recover in real time.
- If the system has an irrecoverable long-term fault or an irrecoverable fault (e.g. camera open circuit), the instrument indicator  on the dashboard illuminates. A text reminder on the infotainment screen informs the user that the system is currently faulty and the fatigue detection function has failed. The driver drowsiness and attention warning system (DDAW) recovers in real time after a long-term fault (or unrecoverable fault) is repaired by human means.
- It is recommended to use a gentle and clean cotton cloth to wipe the camera lens of the driver drowsiness and attention warning system, and be careful to avoid scratching the lens.

### ◆ NOTE

- The camera will not record or share images, audio, or video.

## ADVANCED DRIVER DISTRACTION WARNING (ADDW) SYSTEM

### SYSTEM INTRODUCTION

The advanced driver distraction warning system, abbreviated as "ADDW", mainly monitors the driver's attention state in real time during normal vehicle operation through the detection of DDAW

cameras and the auxiliary detection of some vehicle signals, thereby achieving the driver distraction warning function. The driver distraction behaviors include eye gaze movement, head posture movement, and other behaviors, and the system also provides warning prompts, fault prompts, and other functions.

## ENABLE OR DISABLE ADVANCED DRIVER DISTRACTION WARNING (ADDW) SYSTEM

In the "Settings - Smart Driving - Active Safety" interface of the infotainment screen, tap the Distraction Warning System button to turn on or off the advanced distraction warning function.

## TRIGGER ADVANCED DRIVER DISTRACTION WARNING (ADDW) SYSTEM

With the advanced driver distraction warning system active, when the vehicle is in D gear and the vehicle speed is above 10km/h (6mile/h), and the system detects that the driver's attention is distracted, the vehicle will prompt the driver through a pop-up window on the infotainment screen and an instrument cluster icon  prompt, and warn the driver to drive safely through an alarm sound.



### WARNING

- The advanced driver distraction warning system is only an auxiliary system that cannot ensure effective recognition and issue an alert in all circumstances, and cannot replace the driver's subjective judgment. Do not rely on the system's alerts, the driver must always maintain control of the vehicle and drive normally, comply with road regulations, and take full responsibility for the vehicle.
- Focused driving is very important, and drivers should promptly adjust their driving behavior when a distraction warning appears.
- The advanced driver distraction warning system cannot actively intervene in driving operations; the driver always has the responsibility to drive the vehicle safely and cautiously.
- The advanced driver distraction warning (ADDW) system is an advanced driver assistance systems and cannot work properly under all conditions. You always have the

responsibility to drive the vehicle safely and carefully, and to comply with current laws and traffic regulations.

- Do not drive while distracted. It is the driver's responsibility to maintain a focused and alert driving status at all times.

### ATTENTION

- If there is a recoverable short-term fault of the system (e.g. camera obscured, etc.), the instrument indicator  illuminates. A text reminder on the infotainment screen informs the user that the system is currently faulty and the distraction detection function has failed. After the fault is repaired, the advanced driver distraction warning (ADDW) system will recover in real time.
- If the system has an irrecoverable long-term fault or an irrecoverable fault (e.g. camera open circuit), the instrument indicator  on the dashboard illuminates. A text reminder on the infotainment screen informs the user that the system is currently faulty and the fatigue detection function has failed. The advanced driver distraction warning system recovers in real time after long-term faults (or irrecoverable faults) are repaired by human means.

## VEHICLE ELECTRONIC BRAKE SYSTEM

### ELECTRONIC STABILITY CONTROL (ESC)

#### SYSTEM INTRODUCTION

The electronic stability control (ESC) determines the driver's driving intentions based on information such as steering wheel angle and vehicle speed, and continuously compares them to the actual driving conditions of the vehicle. If the vehicle deviates from normal driving path (e.g. if the vehicle skids), the electronic stability control (ESC) corrects this by applying braking force to the appropriate wheels.

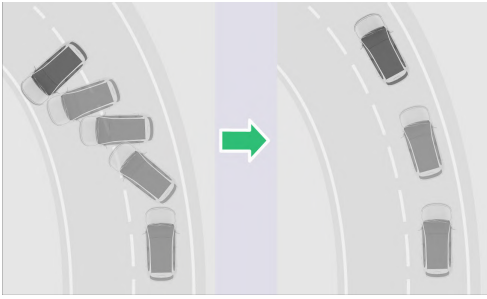

If the vehicle tends to oversteer (i.e., fishtail), the system mainly applies braking to the front wheel on the outside of the curve.

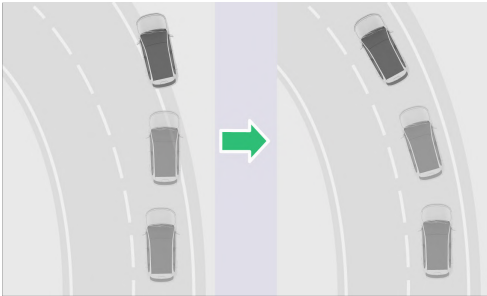

If the vehicle tends to understeer (i.e., the turning radius is too large), the system mainly applies braking to the inner rear wheel of the curve.

Vehicles without electronic stability control slide off the normal driving route while driving, and vehicles with electronic stability control correct the braking force according to the amount of side-slip while driving, preventing deviation from the route.

### ENABLE OR DISABLE ELECTRONIC STABILITY CONTROL

In the "Settings - Driving" screen of the infotainment screen, tap the electronic stability control button to turn the electronic stability control system on or off.

#### **▲ WARNING**

- The electronic stability control is only an auxiliary system; do not take risks by relying on additional safety features provided by the system. Drivers must adjust their speed according to the weather, road, and traffic conditions, and are fully responsible for the safety of their vehicle.
- The electronic stability control (ESC) cannot exceed the physical limits of road adhesion,

and particular care must be taken when driving on slippery surfaces or when towing.

#### **▲ ATTENTION**

- Improper operation or modification of the vehicle (such as modification of the braking system or the performance of the wheels and tires) can all affect the function of the electronic stability control (ESC).

### ANTI-LOCK BRAKE SYSTEM (ABS)

When the vehicle is braked, the wheel speed sensors deliver the wheel speed signals of each wheel to the anti-lock brake system (ABS) in time, and the ABS control unit processes the input signals of the four wheel speed sensors according to the set control logic and calculates the slip rate of the wheels. By controlling the operation of the solenoid valve, the slip rate of each wheel is kept within the ideal range (around 20%), preventing the wheels from locking up.

#### **▲ WARNING**

- The anti-lock brake system (ABS) is only an auxiliary system; do not take risks by relying on the additional safety features provided by the system. Drivers must adjust their speed according to the weather, road, and traffic conditions, and are fully responsible for the safety of their vehicle.
- When you press the brake pedal and hear a harsh friction noise while driving the vehicle, please find a safe area to park as soon as possible and contact an authorized dealer to avoid incidents or injuries caused by brake failure.
- Drivers should always maintain a safe distance from the vehicle in front of them and be aware of dangerous situations while driving. Even though the anti-lock brake system (ABS) can improve braking distance, it cannot surpass the laws of physics, nor can it prevent the dangers caused by tire skidding (such as when there is a layer of water between the road surface and the tire preventing the tire from making direct contact with the road surface).
- The anti-lock brake system (ABS) does not reduce the time and distance required to

brake the vehicle. This device only helps you control the steering when braking. Keep a safe distance from other vehicles.

- The anti-lock brake system (ABS) cannot prevent a loss of stability. Steer moderately when braking in an emergency. Making a wide or sharp turn while driving may cause the vehicle to steer into oncoming traffic or run off the road.
- The anti-lock brake system (ABS) cannot prevent skidding caused by sudden changes in direction, such as trying to make a quick turn or suddenly changing lanes. Regardless of road surface conditions and weather, you should always cautiously drive the vehicle at a safe speed.

#### ⚠ ATTENTION

- Improper work or modifications to the vehicle (e.g., modifications to the braking system or wheel and tire performance) can affect the function of the anti-lock brake system (ABS).
- Tires must be the size specified by the manufacturer; if the tire size is incorrect, or if the sizes of all tires are inconsistent, the anti-lock brake system (ABS) will not work effectively.
- When the vehicle is powered on, the system carries out a self-check. If the system is not operating normally, the anti-lock brake system (ABS) malfunction indicator lamp (MIL)  in the instrument cluster is always on. It is recommended to go to an authorized dealer as soon as possible to have it checked and repaired.

## ELECTRONIC BRAKEFORCE DISTRIBUTION SYSTEM (EBD)

The electronic brakeforce distribution system is part of the anti-lock brake system (ABS). The electronic brakeforce distribution system balances the braking force distribution between the front and rear wheels according to the load on the vehicle during regular braking, avoiding the rear axle locking up before the front axle, and preventing the unstable condition of the rear axle locking up.

After the vehicle is powered up and the electronic parking brake (EPB) is released, if the brake malfunction indicator lamp (MIL)  illuminates,

there is a malfunction in the brake system and the electronic brakeforce distribution system (EBD) may be inoperative. Please stop the vehicle immediately and safely, and contact an authorized dealer as soon as possible to have it checked and repaired.

#### ⚠ WARNING

- Do not continue to drive the vehicle with the brake malfunction indicator lamp (MIL)  illuminated.
- The electronic brakeforce distribution system (EBD) is only a supplemental system; do not take risks by relying on the additional safety features provided by the system. Drivers must adjust their speed according to the weather, road, and traffic conditions, and are fully responsible for the safety of their vehicle.

## TRACTION CONTROL SYSTEM (TCS)

The traction control system (TCS) is an anti-skid control system that determines whether slip occurs in the drive wheels based on the number of revolutions of the drive wheels and the number of revolutions of the driven wheels, and then suppresses the rotational speed of the drive wheels when the former is greater than the latter.

When the vehicle brakes on smooth surfaces, the wheels will slip and even lose directional control. The drive wheels may also slip when the vehicle starts or accelerates sharply, and there is also a danger of losing directional control on smooth surfaces such as ice and snow. The role of the traction control system (TCS) is to control the driving force when the vehicle is accelerating so that the tire slip remains within a reasonable range, thereby maintaining the stability of the vehicle.

#### ⚠ WARNING

- The traction control system (TCS) is only an auxiliary system; do not take risks by relying on the additional safety features provided by the system. Drivers must adjust their speed according to the weather, road, and traffic conditions, and are fully responsible for the safety of their vehicle.

## HYDRAULIC BRAKE ASSIST (HBA)

When the vehicle is braking, hydraulic brake assist (HBA) determines if it is emergency braking based on the speed and force of the driver's foot on the brake pedal. If the system determines it is emergency braking, it will assist the driver in generating greater braking force for a short period of time, thereby shortening the braking distance.

### ▲ WARNING

- Hydraulic brake assist (HBA) can improve driving safety but cannot eliminate the dangers caused by following a vehicle too closely, skidding, speeding, turning too fast, etc., so please drive with caution.

## HILL HOLD CONTROL (HHC)

Hill hold control (HHC) helps the driver assist the vehicle in starting uphill and prevents rolling back when starting.

Also meeting the following conditions will activate the hill start assist system:

- The vehicle came to a complete stop and remained stable on a road surface with a slope exceeding 4% but less than 30%.
- Electronic Stability Control (ESC) no fault.
- The electronic parking brake (EPB) has no fault and is in the released status.
- In drive gear (uphill) or reverse gear (downhill).
- Apply sufficient force to the brake pedal.

If the driver releases the brake pedal on an uphill road, hill hold control (HHC) keeps the vehicle stationary for about 1 to 2 seconds. If no start is made within 1 to 2 seconds, the hill hold control (HHC) function exits. If the vehicle rolls back, the driver should immediately depress the brake pedal.

### ▲ WARNING

- Hill hold control (HHC) cannot keep the vehicle stopped uphill under all circumstances (e.g. slippery ground, snow and ice buildup, or plateaus), and it cannot replace the driver's attention to driving.
- Hill hold control (HHC) is only an auxiliary system; do not take risks by relying on the additional safety features provided by the system. Drivers must adjust their speed

according to the weather, road, and traffic conditions, and are fully responsible for the safety of their vehicle.

- It is strictly forbidden for the driver to leave the vehicle while the hill hold control (HHC) system is operating, otherwise a serious safety incident may occur.
- Do not misuse the hill hold control (HHC) system as a parking brake; this system is only intended to be used as a starting aid in driving.
- When stopping and going on uphill sections in traffic congestion, to prevent the vehicle from rolling backward when starting, please press the brake pedal firmly for a few seconds before starting.
- Hill hold control (HHC) can only prevent the vehicle from slipping for a short period of time, and drivers should exercise caution to avoid the vehicle slipping due to excessive time.

## HILL DESCENT CONTROL (HDC)

### SYSTEM INTRODUCTION

Hill descent control is a speed control function. When the vehicle is descending a steep hill, based on system inputs (hill descent control (HDC) switch, vehicle speed setting, accelerator/brake pedal status, motor torque/revolution, gear, etc.), hill descent control (HDC) actively applies braking to the wheels to ensure that the driver can comfortably and safely traverse steep slopes at low speeds without having to apply the brakes by hitting the brake pedal.

### ENABLE OR DISABLE HILL DESCENT CONTROL

In the "Settings - Driving" interface of the infotainment screen, tap the hill descent control button to turn on or off the hill descent control function.

### FUNCTIONAL LIMITATIONS

The situations where the hill descent control (HDC) function actively exits are as follows:

- Anti-lock Brake System (ABS)/Electronic Stability Control (ESC) fault.
- Brake disc overheated

- The driver depresses the accelerator pedal, and the vehicle speed exceeds the hill descent control (HDC) set limit.

### WARNING

- Hill descent control (HDC) can actively keep the vehicle descending at a constant speed, but it cannot exceed the laws of kinematics. For safety considerations, the driver should, based on the actual situation of the vehicle, apply the brakes timely to avoid incidents caused by the vehicle going downhill too fast.

### NOTE

- When hill descent control (HDC) is in operation, the driver can adjust the vehicle's downhill driving speed by depressing the brake pedal or accelerator pedal, and set the vehicle speed within the range of 8~35 km/h (5~22 mile/h); if the speed exceeds this range, hill descent control (HDC) will automatically exit.

## ANTI-ROLLING SYSTEM (ARP)

The anti-rolling system senses the driver's steering maneuvers and, in conjunction with the vehicle status during driving, intervenes with the wheel braking force and powertrain drive torque at the right time, thus reducing the risk of the vehicle rolling over during lane changes and steering maneuvers.

### WARNING

- The anti-rolling system is only an auxiliary system; do not take risks by relying on the additional safety features provided by the system. Drivers must adjust their speed according to the weather, road, and traffic conditions, and are fully responsible for the safety of their vehicle.

## POST-COLLISION MITIGATION BRAKE SYSTEM

After the vehicle has been involved in a collision, the active brake system automatically controls the reduction of vehicle speed, thereby reducing the risk of a possible secondary collision incident.

### WARNING

- The collision-initiated brake system reduces the risk of a secondary collision by lowering the vehicle's speed after a collision occurs, but it cannot completely avoid a secondary collision. To avoid the danger of a subsequent collision, you can operate the accelerator pedal to drive away from the collision site.

## EMERGENCY STOP SIGNAL (ESS)

When the vehicle performs emergency braking, the electronic stability control (ESC) sends an emergency stop signal and illuminates the hazard warning lamp to alert the vehicle behind.

The emergency stop signal (ESS) function is triggered when the vehicle speed is above 50km/h, the deceleration is greater than 0.6g, or at least one wheel on the front or rear axle triggers ABS modulation.

## AUTOHOLD

### SYSTEM INTRODUCTION

When the vehicle needs to stop frequently or briefly (e.g., waiting at traffic lights, stopping on a slope, or stopping and going with traffic), it can assist the driver in stabilizing the vehicle and preventing it from moving without the driver having to keep the brake pedal pressed. When the driver depresses the accelerator pedal and starts driving, the autohold function immediately releases the brake, and the vehicle then begins to move according to the road inclination.

### ENABLE OR DISABLE AUTOHOLD FUNCTION

Tap the Autohold button in the "Settings - Driving" screen of the infotainment screen or in the "Quick

Actions" screen of the pull-down menu to turn on or off the autohold function.

### AUTOHOLD ACTIVATION CONDITIONS

The autohold function can be activated when the following conditions are met:

- The autohold function has been turned on in the infotainment screen.
- The vehicle power is in READY status.
- All doors are closed.
- The driver fastens their seatbelt.
- Press down on the brake pedal.

### USE AUTOHOLD FUNCTION

After turning on the autohold function, step on the brake pedal to stop the vehicle, then press the brake pedal firmly. When the indicator  lights up, it indicates that the autohold function is active. At this time, release the brake pedal, and the vehicle will remain stationary. Press the accelerator pedal to resume driving.

#### WARNING

- Autohold cannot completely replace driver parking and requires the driver to keep an eye on the vehicle parking status at all times.
- It is strictly prohibited to activate autohold while the vehicle is being towed or driven into the automatic car wash.
- If autohold malfunctions (autohold fault indicator  in the instrument cluster illuminates), stop the car safely and contact the authorized dealer for check and repair.

## AUTOMATIC EMERGENCY BRAKING (AEB)

### SYSTEM INTRODUCTION

The automatic emergency braking system, abbreviated as "AEB", monitors the distance and relative speed of the target ahead. When the driver brakes too late, the braking force is too small, or there is no braking measure, the system will take measures to assist the driver in avoiding or reducing collisions.

## ENABLE OR DISABLE AEB SYSTEM

In the "Settings – Smart Driving – Active Safety" interface of the infotainment screen, tap the automatic emergency braking button to turn on or off the AEB system.

### TRIGGER AUTOMATIC EMERGENCY BRAKING

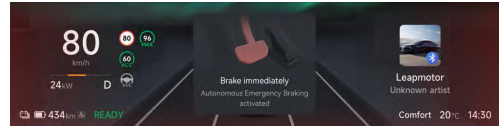

During driving, when the automatic emergency braking function is active, braking measures will be taken and the driver will be alerted through the instrument cluster.

The effective speed range of AEB is 8~150km/h (5~93mile/h) for automobiles, and 8~90km/h (5~56mile/h) for pedestrians, bicycles, and motorcycles.

### FUNCTIONAL LIMITATIONS

Automatic emergency braking (AEB) is designed for frontal collision mitigation only and will not operate when the vehicle is in reverse gear. Use the function with special caution under the following conditions:

- When the vehicle is on a slope, it affects the normal triggering of the function.
- Driving in bad weather such as rainy days or blizzards.
- Stationary obstacles ahead (such as a broken-down vehicle).
- No response to animals, crossing vehicles, and targets with unclear contours. For example: child dummies, traffic cones, kittens, puppies, and irregular obstacles (such as cranes, etc.).
- It may not be able to trigger in time or may not trigger at all for small-profile targets such as motorcycles and bicycles.
- A vehicle is approaching in the opposite direction in the same lane.
- Situations such as large bends or intersections where vehicles cross paths.
- Dark environment (poor lighting conditions) or poor visibility (caused by heavy rain, heavy snow, dense snow, etc.).

- When strong light (such as oncoming headlights or direct sunlight) obstructs the camera field of view.
- The windshield obstructs the camera field of view (e.g., due to fog, dust, or stickers).
- During driving, the system may not be able to brake timely if a vehicle in an adjacent lane suddenly and quickly cuts in front of your vehicle or if the vehicle suddenly cuts into an adjacent lane.
- When your vehicle is traveling above a certain speed, automatic emergency braking (AEB) cannot completely avoid a collision when a pedestrian is detected.
- Automatic emergency braking (AEB) does not work on vehicles traveling against traffic.
- The system cannot operate normally if the front-view camera is dirty or obscured, or if the radar system has collision damage. For radar or camera limitations, see the "Advanced Driver Assistance Systems (ADAS) - Radar and Cameras" section.
- The system cannot issue alarms or initiate braking for stationary obstacles on the road (such as traffic cones, guardrails, water barriers, and guide signs).
- The function may be mistakenly triggered when the vehicle goes by objects such as gantries, tracks, or height limiting poles.
- The function may not be triggered in time if the relative speed difference between the vehicle in front and your vehicle is too large, or if the vehicle in front stops suddenly.
- Targets in curves may not trigger the function due to perception performance limitations.
- If the vehicle is within the lane, and the front vehicle is partially within the lane or the front vehicle is within the lane while your vehicle is partially within the lane, it may not be triggered in time or may not be triggered at all.
- When the vehicle issues a visual or audible warning, the driver is responsible for taking immediate actions to prevent danger to the vehicle.
- When the AEB is turned off, the vehicle will not apply the brakes even if it detects a possible collision. It is recommended that you do not disable this function.
- Braking distance will be extended on slippery surfaces. If the anti-lock braking system, traction control system, or vehicle stability control system is triggered, it may result in a reduction in the ability of automatic emergency braking to mitigate a collision.
- AEB cannot replace maintaining a safe travel distance from vehicles, cyclists, and pedestrians in front of you. Please avoid behaviors such as driving too close to the vehicle in front, cyclists, or pedestrians, or driving aggressively.
- AEB is only used to mitigate the impact of frontal collisions. AEB is inoperative when the vehicle is in reverse gear.
- AEB may warn or apply the brakes when there is no risk of a collision. Stay focused and always keep an eye on the area in front of the vehicle to anticipate if any action needs to be taken.



#### NOTE

- To deactivate the AEB function, you need to tap the pop-up window a second time to confirm the deactivation.
- The AEB function needs to be activated and deactivated when the vehicle is in the Parking gear.

## ELECTRONIC POWER STEERING (EPS)

Electronic Power Steering (EPS) assists the driver in completing the steering operation of the vehicle through the steering motor. It can provide different steering assistance to the driver at different vehicle speeds or under different acceleration modes.

#### WARNING

- If the electric power steering fault indicator  /  illuminates after the vehicle is powered up or while it is being driven, there is a

#### WARNING

- The AEB system is an advanced driver assistance system (ADAS) and cannot prevent collisions. When the system detects an emergency, it can only apply limited braking to reduce collision damage. The driver should always observe the road environment, maintain an appropriate distance from the vehicle in front, and be ready to brake or steer at any time. Overreliance on the AEB system may result in serious bodily injury or even endanger the driver's life.

malfunction in the steering system. Please stop the vehicle safely immediately and contact the authorized dealer.

## PARKING ASSIST SYSTEM

### AROUND VIEW MONITOR

#### SYSTEM INTRODUCTION

The around view monitor can provide the driver with video images of the blind spots around the vehicle, allowing the driver to intuitively see the vehicle's position and the obstacles around the vehicle. Convenient for drivers to maneuver their vehicles into parking spaces or through complex road surfaces, effectively reducing scratches, getting stuck, collisions, and other incidents.

#### ENTER AROUND VIEW MONITOR INTERFACE

The method of entering the around view monitor screen is as follows:

- After starting the vehicle, when the vehicle speed is less than 30km/h (19mile/h), tap the "360 Around View" button icon on the infotainment screen, and the infotainment screen will display the around view monitor interface.
- To open the around view monitor interface via voice
- Press the steering wheel customization button (can be set to trigger 360 Around View on the infotainment screen).
- When the vehicle is shifted to the R gear, the around view monitor interface pops up.

#### EXIT AROUND VIEW MONITOR INTERFACE

To exit the around view monitor interface:

- Tap the other toggle buttons in the bottom bar in the infotainment screen to exit the around view monitor interface.
- To exit the around view monitor interface via voice
- Press the steering wheel customization button (can be set to trigger 360 Around View on the infotainment screen).
- When the vehicle speed on the instrument cluster exceeds the set speed for surround view

suppression, the around view monitor interface will exit.

- Shift the vehicle to P gear to exit the around view monitor interface.

### INTRODUCTION TO AROUND VIEW MONITOR INTERFACE

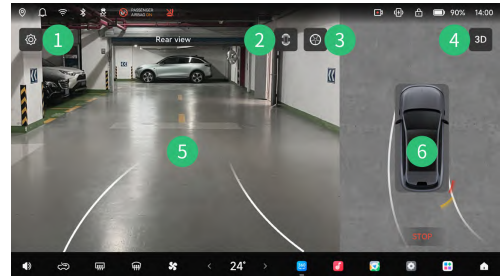

1. Settings button
  - Tap to enable or disable the transparent chassis, dynamic trajectory line, and radar alarm sound functions.
2. Wide-angle view switch button
  - Tap to switch to wide-angle view.
3. Wheel hub view switch button
  - Tap to switch to wheel hub view.
4. 2D/3D switch button
  - Tap to switch to 2D or 3D view.
5. Main view display area
  - Display the main screen from different perspectives.
6. Around view monitor stitching display/radar display area
  - This area displays a panoramic top view, vehicle trajectory line, radar auxiliary line, and obstacle distance alert information, and you can switch the main view screen display by tapping the corresponding area.

### START ASSIST IMAGE

In the "Settings - Smart Driving - Assist Image" interface of the infotainment screen, tap "Start Assist Image" to turn on or off the function.

After the function is enabled, the vehicle comes to a stop. When switching to the D gear, a 360-

degree image interface pops up on the infotainment screen to check for obstacles nearby.

## FUNCTIONAL LIMITATIONS

Camera perceptual performance limitations can affect the normal use of the around view monitor:

- Darkness (poor lighting conditions) or poor visibility (caused by heavy rain, heavy snow, dense fog).
- Weather conditions (heavy rain, snow, fog, scorching heat, or extremely cold temperatures) interfere with camera operation.
- The camera faces directly toward the light source or the light intensity is insufficient.
- The camera surface is covered with foreign objects such as ice, snow, frost, rain, fog, accumulated water, and dust.
- Rapid changes in light (entering and exiting the tunnel).
- The left and right rearview mirrors are deformed or damaged, and the front and rear bumpers are deformed or damaged, resulting in a change in camera position.
- The vehicle bounces or shakes due to uneven roads or other reasons.

### WARNING

- The track line of the around view monitor interface is not completely accurate. When the vehicle's steering mechanism is abnormal, the trajectory line will deviate from the actual driving trajectory. Drivers should pay attention to the surrounding environment at all times, and never rely on the around view monitor system.
- The around view monitor can assist the driver with driving, but it cannot replace the driver. Even if the around view monitor is active, the driver must drive carefully and obey traffic rules.

### NOTE

- The objects displayed on the around view monitor may be somewhat distorted from the actual objects.
- Do not use the around view monitor when the exterior rearview mirrors are not deployed in place, and make sure that all doors are closed in place when operating the vehicle with the around view monitor.

- The distance of an object shown in the around view monitor interface may differ from subjective perception, especially when the object gets closer to the vehicle, and the driver needs to judge the distance between the vehicle and the object based via multiple methods.

## DASHCAM

### SYSTEM INTRODUCTION

During driving, the system records video image data through the camera, displays it on the infotainment screen, and stores the record for future viewing and access.

### DASHCAM INTERFACE

Tap the "Dashcam" application in the application interface of the infotainment screen to enter the dashcam interface, and you can tap to view the following content:

- Live View: Tap the record button to start video recording.
- Loop Video: After inserting the USB drive, the system automatically turns on loop video recording when the vehicle is powered on. By default, videos are recorded every 3 minutes, and the earliest video is automatically deleted in a loop.
- Emergency Video: When the vehicle collides and the airbags are deployed, the dashcam will save the video of this period in the emergency video.
- Settings: You can turn the dashcam on or off, and check the capacity of the USB drive.

### NOTE

- During dashcam recording, if the recording is interrupted due to sudden power cutoff or system reboot (e.g., a serious collision), it may cause the current video to not be saved completely and in time, which may lead to missing video, video save failure, and so on.

### USB DRIVE PLACEMENT



The USB port is located in the lower storage space of the console, and after inserting a USB drive, the dashcam automatically starts recording driving videos.

### **▲ WARNING**

- The dashcam recording function may involve others' personal privacy or national confidentiality requirements related to important geographic location data. Please comply with the relevant provisions of national laws and regulations during operation.
- The quality of dashcam image may deteriorate when visibility is low in inclement weather (e.g., rain, snow, fog).
- If the dashcam system malfunctions, contact the authorized dealer for check and repair in time.

### **USB Drive Selection Advice**

1. Select the supported file format as FAT32, and it has already been formatted as FAT32.
2. Select well-known brands with a storage capacity of 64G/128G/256G.
3. Supports USB 2.0 and above, with a sustained write speed greater than 10MB/s.

### **▲ ATTENTION**

- Do not pull out the USB drive while the dashcam is active, otherwise it may cause data anomalies or damage to the USB drive.
- The USB drive operating temperature is 0~60°C. Ambient temperatures that are too high or too low will greatly affect the read or write speed, thereby causing data read and write failures. The USB drive is a consumable product. If the read/write speed is abnormally

slow or video recording fails, replace the USB drive.

### **🔑 NOTE**

- The vehicle does not come with a dashcam USB drive. You need to install a USB drive yourself to use the dashcam function properly.

## IN-CAB INSPECTION

### CHECK DRIVER'S SEAT

Check that the driver's seat position fore and aft adjustment, height adjustment, and backrest angle adjustment are smooth, and ensure that the seat is adjusted to the proper position.

### CHECK SEAT BELT

Check whether the seat belt retractor and seat belt buckle work properly and smoothly, and whether they are securely installed. Check whether the seat belt is cracked, scuffed, worn, or damaged.

### CHECK ALL TYPES OF MIRRORS

Check the instrument cluster screen and infotainment screen for proper functioning, cracking, scuffing, or damage.

### CHECK REMAINING BATTERY LEVEL

Check the state of charge (SOC) shown on the instrument cluster, and recharge the battery when the state of charge (SOC) is insufficient.

## VEHICLE OIL AND TIRE INSPECTION

### CHECK WINDSHIELD WASHING FLUID

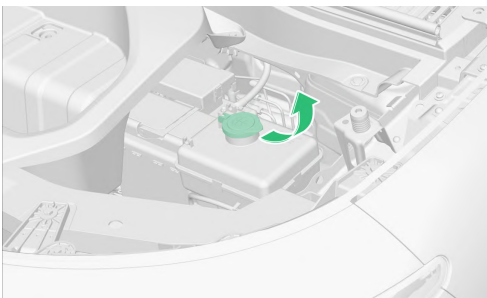

Check IF there is sufficient washing fluid in the windshield washer fluid reservoir, and replenish it if there is insufficient washing fluid. Add windshield washing fluid as follows:

1. Open the bonnet and washer fluid reservoir cover.
2. Add a suitable amount of washing fluid to the washer fluid reservoir (do not overfill).

#### ⚠ WARNING

- Do not add any additives to the windshield washing fluid. Otherwise, cleaning the windshield will leave oil stains or other debris on the windshield, seriously affecting the front view, and very likely to cause an incident.

#### ⚠ ATTENTION

- Do not use soapy water or other antifreeze instead of washing fluid, as it may cause streaks on the vehicle's paint surface.
- Do not mix windshield washing fluid with other cleaners, as it may cause the components of the cleaning agent to decompose and block the windshield washer nozzle..

### CHECK COOLANT

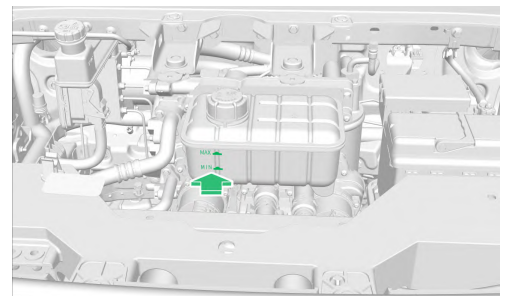

Open the bonnet, remove the front engine compartment storage box\*, and check the coolant level while the coolant is cold to ensure that the level is between the MIN (minimum) and MAX (maximum) marks.

#### ⚠ WARNING

- Do not open the coolant expansion tank cap while the coolant is very hot, as this may result in personal injury such as burns.
- Coolant must be stored in labeled containers inaccessible to children.

- Avoid getting the coolant on your skin. If it does get on your skin, rinse immediately with water.

### ⚠ ATTENTION

- If the coolant is found to be below the MIN (minimum) level, there may be a leak in the cooling system, and contact the authorized dealer.
- The coolant added must not be mixed with coolant not approved by our company; otherwise, the vehicle may be damaged due to incompatibility.

### ♻ ECO

- Waste coolant must be disposed of in compliance with environmental laws and regulations. Do not dump it directly onto garbage dumps, sewers, or the ground.

## CHECK BRAKE FLUID

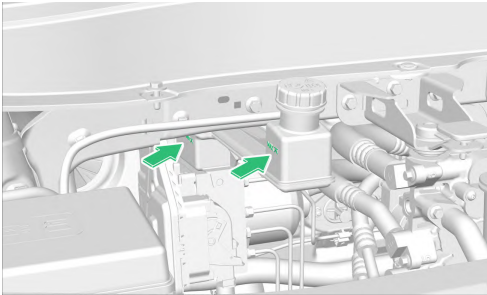

Open the bonnet, remove the front engine compartment storage box\*, and check the brake fluid level to ensure it is between the MIN (minimum) and MAX (maximum) marks.

### ⚠ WARNING

- Use only new brake fluid that has been stored in a sealed container. Do not use brake fluid that has been used or opened, as brake fluid absorbs moisture and reduces braking performance.
- Brake fluid is highly toxic, and should be stored in a sealed container to avoid contact with children. If accidentally ingested, seek immediate medical attention.

- Do not store brake fluid in empty food containers, bottles, or any non-original brake fluid containers, otherwise, brake fluid may be mistaken for food, resulting in poisoning accidents.
- It is normal for the brake fluid level to drop slightly due to automatic adjustment caused by brake pad wear during vehicle use. However, if the fluid level drops in a short period of time, or drops below the "MIN" mark, or requires frequent refilling, it indicates a fault in the brake system.

### ⚠ ATTENTION

- Brake fluid can only be changed at the authorized dealer.
- Brake fluid can damage the paint surface. Do not spray brake fluid on the paint surface. If brake fluid is sprayed on the paint surface, clean it immediately with water.
- Brake fluid is hygroscopic, and constantly absorbs moisture from the surrounding air during use. If the water content of the brake fluid is too high, it will corrode the brake system and also greatly reduce the boiling point of the brake fluid. During emergency braking, gas resistance may occur, deteriorating the braking effect. Therefore, the brake fluid must be replaced regularly.
- Brake fluid must be changed every 2 years or 40,000 kilometers (24,855 miles).

### ♻ ECO

- Waste brake fluid must be disposed of in compliance with environmental law and regulations. Do not dump it directly onto garbage dumps, sewers, or the ground.

## CHECK TIRE PRESSURE AND TREAD

For your driving safety, please have your tires inspected regularly.

- In the cold tire status (at least 3 hours of parking), check whether the tire pressure meets the tire requirements for this vehicle.
- Check the tire tread for cuts, bulges, cracks, excessive wear, or other damage.

**▲ WARNING**

- When the vehicle is moving, if abnormal vibration or deviation is detected, you should immediately stop safely and check whether the tires are damaged.
- Vehicle tire pressure needs to be checked before long-distance driving, as abnormal tire pressure may lead to tire blowouts and traffic incidents.

## A/C AIR FILTER ELEMENT CHECK

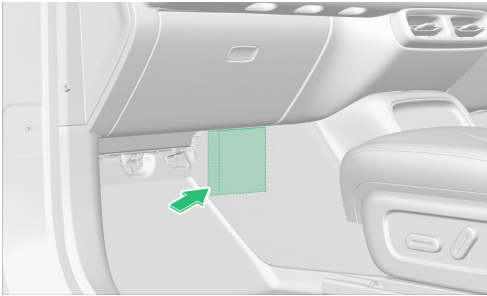

The A/C filter is located underneath the console, and regular cleaning of the A/C filter can keep the air in the compartment fresh.

**▲ ATTENTION**

- To clean the A/C filter, remove the console left extension plate assembly and the air filter cover plate. To avoid damage to the vehicle, it is recommended to contact the authorized dealer for A/C filter cleaning.

## CHECK AFTER STARTING THE VEHICLE

### CHECK THE OPERATION OF THE INSTRUMENT CLUSTER

Inspect whether the instrument cluster lights and display are normal.

### CHECK THE HORN

Check if the horn and buzzer are functioning normally.

## CHECK THE LIGHTS

Check that the front combination lamps, stop lamps, direction signal lamps, and other lighting equipment are operational and securely fastened, and check that the headlamp's illumination height is normal.

## CHECK THE WIPER AND WASHER

Check if the wiper is working properly and make sure that the wiper blade does not leave scratches after wiping; otherwise, replace the wiper blade promptly.

Check that the washer is working properly and spraying the washing fluid properly.

## CHECK THE STEERING WHEEL

Check whether the steering wheel multifunction buttons are functioning properly and whether the steering wheel surface has any damage.

## VEHICLE TRIAL OPERATION INSPECTION

### CHECK BRAKE SYSTEM

Check the free stroke of the brake pedal to ensure that when the brake pedal is fully depressed, there is proper clearance underneath, and make sure that the floor mat does not impede the operation of the brake pedal.

Check whether the brake system is working properly and whether there is any abnormal noise from the brake disc and brake pad when braking.

Check the parking brake for proper function.

### CHECK THE STEERING SYSTEM

Check whether the steering responds normally, whether the steering wheel free stroke is excessive, whether the steering is heavy, or if there are other abnormal noises.

## VEHICLE MAINTENANCE

### MAINTENANCE INSTRUCTIONS

To ensure good performance of the vehicle, it is necessary to maintain the vehicle during use:

- Maintenance is divided into regular maintenance and routine maintenance. Regular maintenance is performed by the authorized dealer, and routine maintenance is mainly performed by the driver.
- When performing any maintenance or inspection operation, always follow safe operating procedures. Incorrect operation may cause faults or damage to the vehicle functions, or even an incident.

Timely regular maintenance of the vehicle is an essential part of its use. Refer to the chapter on maintenance content and the maintenance interval table for mileage or time intervals and maintenance items for regular maintenance. You can also visit the authorized dealer for regular maintenance timely according to the maintenance mileage reminder on the infotainment screen, and re-initialize the maintenance mileage reminder.

Routine maintenance check should be performed before each drive. Routine maintenance is the responsibility of the driver and can be done by the driver himself. If necessary, contact the authorized dealer.

#### ATTENTION

- Failure to perform regular maintenance on the vehicle timely will reduce the vehicle performance, cause vehicle damage, and forfeit the right to make a warranty claim.

### PREVENTING CORROSION

#### VEHICLE PARKING

Park the vehicle in a well-ventilated environment whenever possible. Do not park the vehicle for long periods of time in damp, cold, hot, or airtight locations.

#### PAINT DAMAGE

Small paint damage such as scratches, scuffs, or bruises should be repaired immediately by

contacting an authorized dealer to avoid metal corrosion.

### WHEEL MUDGUARD

When driving on saline-alkali roads or gravel roads, the mudguards can effectively protect your vehicle and ensure the safety of the vehicle behind you. The larger the size of the mudguard and the closer it is to the road, the better the protection for the vehicle behind. If you need to install mudguards, we recommend contacting an authorized dealer.

### NOTES ON ROUTINE MAINTENANCE ITEMS

When drivers perform routine vehicle maintenance, please pay attention to safety and follow safe operating procedures to avoid injury to yourself or damage to the vehicle. If you have any questions about the maintenance or repair of your vehicle, we recommend contacting an authorized dealer.

#### WARNING

- When performing routine vehicle maintenance, park the vehicle in a safe area, on a level surface, and apply the electronic parking brake (EPB). Do not perform vehicle routine maintenance in areas with heavy vehicle traffic, heavy foot traffic, flammable, explosive, or other unsafe areas, or on ramps.
- When performing routine vehicle maintenance, you should take off loose clothing, tie up long hair, remove jewelry such as bracelets and watches, wear gloves, and take appropriate protective measures.
- During routine inspection or periodic maintenance, promptly remove foreign objects from the front engine compartment, and do not leave flammable items or tools such as gloves or rags in the front engine compartment.
- Do not disconnect or connect the battery cables and other electrical component plugs after the vehicle is powered on.
- It is strictly prohibited to bring items with sparks or flames close to the battery.
- Avoid direct skin contact with used waste oil.

## BODY CLEANING

Washing your vehicle frequently helps protect the vehicle's appearance. Please clean the vehicle according to the normal car wash method.

The following conditions will cause the paint layer to flake off or lead to corrosion of the body and parts, and the vehicle must be washed immediately:

- After traveling along the coast for a while.
- After driving for a period of time on roads sticky with coal tar, resin, bird droppings, and dead insects.
- After driving for a period of time in areas containing large amounts of soot, coal ash, dust, iron filings, or chemicals.
- The vehicle was obviously soiled with dust and mud.

## HAND CAR WASHING

In the shade, wait for the vehicle to cool down sufficiently before washing the vehicle.

1. Use a water pipe to wash off all loose dirt, all mud or road salt and alkali from the underside of the vehicle and the sunken parts of the wheels.
2. Soak a sponge with car wash detergent and gently wipe to remove dirt.
3. Clean the tires with the special sponge and brush used for cleaning tires.
4. Thoroughly rinse the vehicle.
5. In order to prevent water stains on the body, the body must be wiped dry with a special water-absorbent towel. Do not rub or press hard, as this may damage the paintwork.

### WARNING

- When cleaning the chassis, care must be taken to avoid cutting your fingers.
- Do not wash the vehicle while it is charging.
- Do not flush high-voltage devices on the underside of the vehicle to avoid electric shock incident or vehicle damage.

### ATTENTION

- Please use specialized cleaners and conditioners when washing and waxing your car, pay attention to the shelf life before use,

and be sure to store them out of reach of children after use.

- Do not wash the vehicle in direct sunlight, as there is a risk of damaging the paint.
- When washing your vehicle in winter, if you use a hose to rinse the vehicle, please make sure the spray is not directed at the exterior door handles, charging ports, and door seams, otherwise these areas may freeze.
- Do not use rough sponges or corrosive cleaners to clean the vehicle to avoid damage to the paintwork.
- The washing water temperature must not exceed 60°C.
- The charging port cover plate should remain closed during the car wash to avoid damage to the vehicle.
- Too high water pressure during a high-pressure car wash can damage the paint.
- Do not spill water in the front engine compartment to avoid short-circuiting of electrical parts.
- Do not use highly alkaline laundry detergents, soapy water, dewaxing detergents, organic substances (gasoline, kerosene, volatile oils, or strong solvents).
- Do not dry wipe the vehicle lamps or use abrasive cleaners to clean the vehicle lamps to avoid scratching them.
- Do not wax the surface of the vehicle lamps to avoid damage to the vehicle lamps. Cleaners containing alcohol or organic cleaners (e.g., adhesive removers, tar cleaners, coatings, foam detergents, paint iron powder cleaners, glass detergents, thinners, deicing agents, paint surface treatment agents, etc.) may damage the vehicle lamps and cause cracking. Protect the vehicle lamps when performing vehicle washing or car coating operations.
- Do not scrub the body with cleaners containing abrasives.
- Plated metal parts should be protected by waxing them periodically.

## AUTOMATIC CAR WASHING

When washing a vehicle at an automatic car wash station, be aware that certain types of brushes, unfiltered rinse water, or the machine's self-programmed rinse cycle may scratch the paint surface. Scuffing of the paint surface will reduce the durability and gloss of the paint finish, especially on dark-colored vehicles.

It is best to consult with the staff at the car wash station before washing your car to choose the wash procedure that is safest for your vehicle's paint surface.

### ECO

- Vehicles should be washed at a professional car wash, which can prevent wastewater containing oil from being discharged directly into the sewers and avoid polluting the environment.

## VEHICLE WAXING

To keep your vehicle polished and shiny as new, we recommend body polishing and waxing once a month or when the body surface does not resist water well.

- Before waxing, always wash and dry the car body, even if you are using a synthetic combination of cleaner and wax.
- Use high-quality polishes and car wax. If the body polish is heavily weathered, use a vehicle cleaning polish separate from the vehicle wax. Carefully follow the manufacturer's instructions and precautions. The chrome surface should be polished and waxed just like the painted surface.
- When the body surface extensively contacts water and water does not form droplets but remains attached to the body surface, the vehicle should be re-waxed.

### ATTENTION

- When waxing and conditioning, avoid the vehicle radar probes.

## PAINT MAINTENANCE

Here are a few things to keep in mind when taking care of your vehicle's paint surface:

- Rinse promptly after rain. The rain stains on the body will gradually shrink after the rain, causing the concentration of acidic substances in the rainwater to gradually increase. If the rain stains are not rinsed off with clean water promptly, they will damage the paint over time.
- When washing the car, use a special cleaner and neutral running water. Do not use highly alkaline laundry detergent, soapy water, or detergent

liquid, to prevent washing away the oil in the paint and accelerating the aging of the paint. If washing your car at a car wash, you should remind the car wash personnel not to use wax-removing cleaners to avoid damage to the paint surface. In particular, vehicles traveling in coastal or heavily polluted areas should be washed once a day.

- Scrub the vehicle with a clean, soft cloth or sponge to prevent mixing in metal shavings and sand particles. Do not use a dry cloth, dry towel, or dry sponge to wipe the vehicle, so as to avoid leaving scratches. When wiping, wipe gently from top to bottom in the direction of the water flow; do not wipe in circles or horizontally.
- For some special and highly corrosive traces (such as asphalt, bird droppings, insects, etc.), they should be removed promptly. In this regard, it must be cleaned with a special cleaner, and you must not randomly use a razor blade to scrape or remove it with gasoline, so as not to damage the paint surface.
- Please do not touch the body paint with dirty hands stained with oil or use oil-stained rags to randomly wipe the paint surface. Please do not place tools stained with oil or rags containing organic solvent on the body to avoid chemical reactions.
- If the paint surface has no obvious scratches, do not easily perform a second painting to prevent color mismatch or poor adhesion.
- Prevent strong impacts, knocks, and scratches on the body paint film. If you find any scars, dents, or peeling of the paint, it should be repaired in time, and it is recommended to go to an authorized dealer for repair.
- Plated metal parts should be regularly waxed for protection.
- For cleaning the body trim, use a good quality detergent. When applying wax, do not rub too hard to avoid penetrating the paint.
- Wax the paint surface irregularly for protection and recommend regular maintenance (once every quarter) at the authorized dealer to promptly restore the bright gloss of the body paint surface.

## CLEANING AND MAINTENANCE OF EXTERNAL PLASTIC PARTS

Usually cleaned with water and a soft cloth or soft brush. If it cannot be cleaned thoroughly, please use a special plastic parts cleaner.

## CLEAN GLASS

Clean the window glass, interior and exterior rearview mirrors, camera, and screen with an alcohol-based glass detergent, then dry the surfaces with a clean, soft cloth.

After caring for the body surface, wax remaining on the glass should be removed with a special cleaner and cleaning cloth to avoid scratching the front wiper blade.

If there is snow, use a plastic scraper to remove snow from the windows and rearview mirrors.

If there is ice on the window glass, you can use a de-icing spray to remove the ice build-up, or you can use a de-icing scraper, but you need to be especially careful so as not to damage the parts, and you must also scrape in the same direction when you use it.

### ⚠ ATTENTION

- When using a de-icing shovel, it is strictly forbidden to scrape back and forth in different directions.
- Do not use warm or hot water to remove ice or snow from the windshield and rearview mirrors, as this may cause the glass to burst.
- If there are residues of rubber, grease, and silicone substances on the glass, they must be removed with a special window cleaner or silicone cleaner.
- Do not use the wiper directly to clear snow.
- When cleaning the inside of the windshield, take care to avoid rubbing or damaging the heater wire and connectors.

## CLEANING THE INTERIOR

When cleaning the interior of the vehicle, please read the following tips first.

### ⚠ WARNING

- Do not allow the airbag components or wires in the vehicle to become wet, as this may cause the airbag to fail to deploy or the airbag to deploy accidentally, which could result in serious injury or even be life-threatening.
- Do not use polishing wax or polishing cleaners. Otherwise, the instrument panel

may reflect onto the windshield, obstructing the driver's view and causing serious injury or even endangering life.

### ⚠ ATTENTION

- Do not spill liquids such as detergents into the car, as this may cause faults in electrical parts due to moisture. If spilled inadvertently, all spilled liquids should be wiped up quickly.
- If you need to use a cleaner, please read the cleaner's instructions carefully and follow them strictly. Avoid using organic substances (solvents, kerosene, alcohol, gasoline, etc.) or acid and alkali solutions, as these chemicals will cause the surface to discolor, stain, or peel.
- Certain colored garments made of specific materials (such as dark jeans and sheepskin garments) may stain the interior fabric. If this occurs, be sure to clean and care for the fabric in these areas as soon as possible.
- Do not spray detergent directly onto the components with electrical buttons and control units. It should be wiped with a soft cloth dipped in detergent.
- Sharp objects may damage the fabric finish.
- Do not use solvent-based cleaners to clean the instrument panel, airbag trim cover, or leather products.
- Do not spill water inside the vehicle to avoid short-circuiting of electrical parts.

## CLEANING THE INSTRUMENT PANEL AND OTHER INTERIORS

The following precautions should be referred to when cleaning the instrument panel and other interior trim:

- To clean the instrument panel, a clean, soft cloth should be dampened in warm water and the dust gently wiped away.
- Do not use razor blades or other sharp objects to clean dirt on interior surfaces.
- Do not use a stiff-bristled brush; it may damage the vehicle's interior surfaces.
- Please do not use excessive force or press hard when wiping. Using too much force will not only fail to remove scale but also damage the interior.
- You should try to use a mild, neutral soap and avoid using strong detergents or degreasing soaps.

- Do not wet the interior when cleaning.

## ENVIRONMENTALLY FRIENDLY LEATHER CARE

### Daily maintenance

To maintain the best appearance and extend the service life, surface cleaning can be performed periodically. A light rub with a velvet brush will restore the shine, then vacuum clean and gently wipe clean with a dry or damp white cloth.

### Dust stains

Use a vacuum cleaner immediately to clean, or use a lint roller to remove dust stains.

### Light-colored liquid stain

Using a wrung-out damp white cloth, wipe the stain in a circular motion for about 2 minutes. Repeat the above steps with a new wiping cloth until the stain fades and is removed. After cleaning, use a soft white cloth to gently dry the water or let it air dry naturally. Avoid using a hair dryer to accelerate drying.

### Dark-colored liquid stain

In case of dark-colored oil stains, soup, cola, coffee, sludge, etc., first use a wrung-out wet white cloth to wipe the stains for 2 minutes; then moisten the wipe with cleaner or soap and water, and gently wipe the stains for 2 minutes; in case of more difficult to erase stains, moisten the wipe with an ethanol solution (50%~75% concentration), and quickly and gently wipe; and finally use a dry cloth to wipe for 1 minute.

Repeat the above steps 3 times, and if it is still not wiped clean, do not attempt vigorous or frequent wiping.

### Protection from the sun

Prolonged exposure to sunlight can discolor and fade the seat, try to park in a shaded area or use a sun visor to protect the seat.

### Preventing contamination

Avoid eating on the seat to prevent food residue and stains from contaminating the seat. If you

need to eat in the car, you can use a cover or plastic bag to protect the seat.

### Keep away from heat sources

Do not place non-insulated boiling water cups on leather surfaces.

Do not use a hairdryer to blow hot air close to the surface of the leather.

### Avoid contact with sharp objects

Try to avoid letting the seat come into contact with hard or sharp objects, such as keys, repair tools, or pointed items, to prevent scratches.

### Avoid using chemical cleaners

A weak alkaline cleaner should be used, and the use of chemical cleaners and solvents should be avoided to prevent damage to the leather. If sunscreen, skin care products, or oils drip, wipe them off promptly.

### Keep the interior of the car dry

If the humidity inside the car is too high on a rainy day, start the A/C to dehumidify or ventilate the car to cool it off. Do not place wet cloths or similar items on leather surfaces.

## CLEAN SWITCH

When cleaning the switch, use a small, soft-bristled brush to flick dust off the buttons and switches.

## CLEAN SEAT BELT

To clean the seat belt, use a sponge or soft cloth dampened with neutral soapy water or warm water. Check the seat belt regularly for excessive wear or scratches.

### ▲ ATTENTION

- You must wait until the seat belt is completely dry before rewinding the seat belt, otherwise damage to the seat belt retractor will occur.
- Do not use bleach powder, dyes, or cleaning solvents; such items can reduce the durability of the seat belt.

## CLEAN CARPET

Please clean the carpet as follows:

- A high-quality foam-type cleaner should be used to clean carpets.
- First, use a vacuum cleaner to remove as much dust as possible, then scrub the carpet in a circular motion with a foam-soaked sponge or brush.
- Do not use clean water, as it may soak in and cause corrosion of the body, please keep the carpet dry.

## SEALING STRIP MAINTENANCE

The vehicle's sealing strips play a sealing role because of their rubber properties. The sealing strips on the car need to be regularly maintained with a rubber maintenance agent, which can keep the sealing strips elastic for a long time.

## TIRE

To drive the vehicle safely, the tire type and size must match your vehicle model, and all tires must have good tread and standard tire pressure.

### TIRE PRESSURE

Maintaining proper tire pressure can improve vehicle maneuverability and driving comfort, and is beneficial for extending the tread life of tires.

#### ⚠ ATTENTION

- Using tires with insufficient tire pressure can lead to uneven tire wear and affect vehicle maneuverability and power consumption, and is more likely to cause air leak due to overheating, which in severe cases can result in loss of vehicle control.
- Using tires with too high tire pressure will reduce the vehicle comfort, and they are also more likely to be damaged by the unevenness of the road surface. In serious cases, there is a risk of a blowout, which seriously threatens the safety of the vehicle; it will also lead to uneven tire wear, affecting the tire life.

## TIRE WEAR

Each time you check the tire pressure, you should also check the tires for external damage, foreign object punctures, and their wear. Tire replacement is required under the following conditions:

- Damage and bulges on the tread or sidewall. If any such condition is found, the tire should be replaced.
- Scratches, cracks, or breaks on the sidewall of tire. If the tire fabric or cords are visible, the tire should be replaced.
- Excessive tread wear.

### Wear Mark



Tires are equipped with wear markings. The triangular pattern on the shoulder of the tire is used to indicate the position of the tire tread wear indicator mark. You can find the tire tread wear indicator mark through this mark.

The height of the raised "Tread Wear Indicator Mark" is 1.6mm. If the tread pattern is worn down to the surface of the mark, it means that this tire is no longer safe to use and must be replaced immediately.

## CHANGE TIRE

The original tires of this car are selected to maximize vehicle performance, providing you with the best combination of maneuverability, ride comfort, and service life.

It is recommended that you purchase original tires from the authorized dealer.

Replacing with radial tires of different sizes, load ranges, rated speeds, and maximum cold tire air pressures (marked on the side of tire), or mixing radial tires and bias tires, will reduce the vehicle's braking ability, driving force (ground adhesion), and steering accuracy.

Installing unsuitable tires can affect the operating flexibility and stability of the vehicle and may lead to incidents resulting in injury or death.

### ▲ ATTENTION

- When replacing tires, replace them in pairs; do not mix different sizes or different types of tires.
- Do not use tires of any size other than those recommended by Leapmotor.

### Tire Rotation

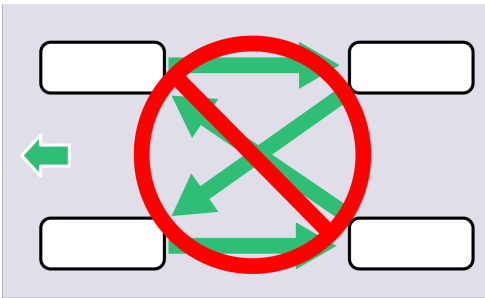

Never rotate the front and rear axle tires, as the size of tires or wheels on the front and rear axles of the vehicle is different. Rotation of the front and rear tires may seriously affect the driving characteristics and may also damage surrounding related components.

### BRAKE WEAR

This vehicle is fitted with a wear indicator for the brake pad. The wear indicator is a thin metal plate attached to the brake pads. When the brake pads are worn to the limit position, it will make a sharp sound. This sound indicates that the brake pads have reached their service life and need to be replaced. It is recommended that you contact the authorized dealer to replace the brake pads.

## BATTERY

### BATTERY ASSEMBLY PRECAUTIONS

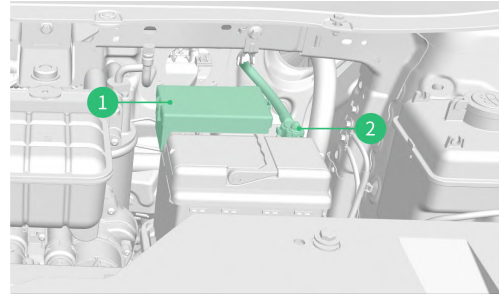

1. Positive Terminal
2. Negative Terminal

The battery is located in the vehicle front engine compartment. Open the bonnet and remove the front engine compartment storage box\* to see it. Before installing the battery, the battery pressing plate should be fixed firmly, and the battery post fixing clamps should be fixed firmly and in good contact to prevent sparking and causing battery explosion.

### BATTERY MAINTENANCE

To extend battery life and maintain proper operation of the vehicle electrical system, we recommend:

- Prevent the battery from overcharging or long-term deep discharge.
- The battery should be kept away from heat sources and open flames, and ventilation should be maintained during charging to prevent burns and injuries.
- Prevent the battery from long-time high-current discharge.
- Oxides and sulfuric acid salts from the battery fixing clamps must be scraped off, and petroleum jelly applied to prevent rusting.

### ▲ WARNING

- If the electrolyte comes into contact with the eyes or skin, immediately flush with plenty of water and seek medical attention.

### ▲ ATTENTION

- If the battery is severely discharged (such as when the vehicle is not used for a long time), it is recommended to contact the authorized dealer. Please do not replace the battery by yourself.
- When you leave the vehicle, please make sure to turn off the vehicle's electrical equipment, such as lights, multimedia, etc., and place the vehicle in a cool, dry place.
- When the vehicle is driven in cold areas, avoid fully discharging the battery to prevent the electrolyte from freezing.
- Frequently check the battery surface and the positive and negative terminals to ensure that the battery positive and negative terminals are not loose or corroded.
- Check the exterior condition of the battery for cracks, swelling, etc. If the above phenomena occur, it is recommended to contact the authorized dealer for check and repair as soon as possible.

When charging a battery, the hydrogen produced by the battery is a flammable and explosive gas. Therefore, the following should be noted before charging:

- When using the charger to charge the battery, the battery should be removed to prevent accidents.
- When connecting and disconnecting the charger cables to the battery, make sure the power switch on the charger is turned off.
- When replacing the battery, you must use a battery of the same model and specification. It is recommended to contact the authorized dealer for replacement.

 **ECO**

- The recycling of batteries must be carried out by qualified units to avoid environmental pollution and harm to the operator.

## POWER BATTERY

### POWER BATTERY CHARACTERISTICS

The power battery is the power source of the vehicle and can be repeatedly charged and discharged. The power battery is charged through an external power supply, and the vehicle can also

recharge the power battery by means of energy recovery when braking or coasting.

 **NOTE**

- The power battery is located under the body chassis. When the vehicle passes over bumpy surfaces or drives on uneven roads, be careful to prevent collisions.

Under the influence of the electrochemical characteristics of the battery itself and for the purpose of protecting the power battery, it is normal that there are some differences in the performance of the vehicle under the following conditions:

- At high battery levels, the power battery's vehicle energy feedback performance will be weakened; when the battery level decreases, it will be enhanced. During this period, the feedback performance has an enhanced transition phase.
- The power battery will switch to trickle charging mode when charging to a high battery level, the end charging time is lengthened, and the estimated remaining charging time displayed will be off.
- When the power battery level is  $\leq 20\%$ , the power performance of the whole vehicle may be weakened.
- It is normal that the power battery's charging and discharging ability will be weakened at high or low temperatures, and the charging time will become longer. When driving under extreme temperatures, power performance may be reduced.
- Power batteries have a reduced amount of usable battery level at low temperatures, and the usable battery level decreases as the temperature decreases. Vehicles charging at a high battery level while parked in a low temperature environment may experience a rapid increase to 100% battery level. Vehicles should be avoided from being parked for a long time in a low-temperature environment when they are in a low battery state.

Under normal conditions, the driving range of a vehicle is affected by the following factors:

- Driving habits: e.g., frequent acceleration and deceleration results in a shorter range than constant speed driving, and high-speed driving results in a shorter range than low-speed driving.

- Road conditions: If the road is bumpy or has a long slope, the range will be shorter than on a flat and dry road.
- Temperature: The range will be shorter in low temperature environments than in normal temperature environments.
- The use of electrical equipment, such as the A/C being on during vehicle use, will result in a shorter range than when the A/C is off.

During low-temperature DC charging, the temperature control system can significantly improve the battery's low-temperature charging capability and enhance the vehicle's charging performance.

During low temperature low power AC charging, limited by the charging power, the battery's self-generated heat is small. To enhance the battery level during charging, battery heating will be activated at this time. The heating energy consumption will increase compared with DC charging, and the charging time will also increase. This is a normal performance of charging in a low temperature environment.

To enhance the car experience, it is recommended that you charge the battery immediately after use, when the battery temperature is relatively high, which can improve charging performance. If the battery temperature is low, the battery may quickly reach the end of charge status to avoid damage to the battery.

When charging at low temperatures with the A/C on, the performance of the battery temperature control system will be affected, which will also affect the charging performance of your car.

### POWER BATTERY USAGE RECOMMENDATIONS

To extend the life of the power battery and enhance your car experience, we recommend:

- The ambient temperature will affect the performance of the power battery. It is recommended to use the vehicle at an ambient temperature of  $-10^{\circ}\text{C}\sim 40^{\circ}\text{C}$  to keep the performance of the power battery good and prolong the service life of the power battery.
- When the power battery low battery warning lamp in the instrument cluster illuminates for the first time or the battery level is  $\leq 10\%$ , in order to ensure sufficient driving mileage and good acceleration performance, please recharge the vehicle within 72 hours. If the power battery is

not charged for an extended period of time, the self-discharge of the power battery may lead to over-discharge of the battery, causing irreversible damage, and the resulting serious fault and damage to vehicle parts will not be covered by the warranty.

- Do not store the vehicle for a long period of time (more than 15 days) in a high temperature (above  $40^{\circ}\text{C}$ ) environment, otherwise it will reduce the service life of the power battery.
- When using the vehicle, it is recommended to avoid frequent rapid acceleration and deceleration, choose flat and dry roads to drive, and if necessary, turn off the A/C and other high-power electrical equipment or adjust the temperature of the A/C to reduce the power consumption of high-power electrical equipment and increase the driving mileage.
- Charging with an AC charger will extend the life of the power battery.
- When using the vehicle for the first time or using it again after a long period of parking, there may be a deviation between the battery level shown on the instrument cluster and the actual one, so it is recommended to fully charge the vehicle once first.
- In order to keep the power battery in optimal status, fully charge the power battery using a charging device on a regular basis (a full charge at least once a week is recommended). Every 3~6 months, perform a full charge (recommended to prioritize slow charging) operation when the battery level is low ( $\leq 5\%$ ). When the power battery level is  $\leq 10\%$ , it is recommended that the vehicle gear position is in Park (P), and A/C, multimedia, and other discharging methods are used to discharge the battery to below 5%.
- Under extreme working conditions (such as continuous rapid acceleration, rapid deceleration, etc.), if the temperature of the power battery is too high, the discharge capacity of the power battery will gradually decrease, which is a normal phenomenon. If the battery temperature continues to rise and the power battery temperature high indicator light lights up, at this time it is recommended to contact an authorized dealer.
- Battery heating is a slow-heating type of heating. When driving for a short period of time, the battery temperature control system is not effective, and it also increases power consumption and shortens the driving mileage. When driving for long periods of time, the battery's own heat causes the temperature to

continuously rise, and at this time your car's battery heating demand is low. The main function of the battery temperature control system is to ensure low-temperature charging performance to enhance your car experience.

- For long-term parking, store the vehicle in temperature-appropriate areas such as underground garages or ambient temperature storage to reduce battery lifespan loss and ensure vehicle performance.
- When the vehicle is not in use, it should be locked and powered off in a timely manner.
- When the battery level is below 10%, the parking time should not exceed 3 days.

### WARNING

- To avoid personal injury, do not directly touch the power battery.
- If the power battery is damaged and there is liquid leakage, do not touch the liquid; if it accidentally comes into contact with the skin or eyes, rinse immediately with plenty of water and seek medical attention immediately.
- If the power battery catches fire, please use a large amount of water to cool down and extinguish the fire, and do not use a dry powder fire extinguisher.
- If the power battery is subjected to severe mechanical damage, resulting in the exposure of the internal high-voltage components, there is a risk of violent combustion and electric shock, which may lead to serious injury or death and environmental pollution.
- It is prohibited to touch the positive and negative terminals of the power battery box at the same time at any time.
- Do not spray, step on, hit, or damage this component to prevent fire or explosion caused by corrosive chemicals.
- The power battery pack is a high voltage part, and it is strictly prohibited to open or repair the power battery pack privately.
- Do not disassemble, move, or alter the power battery parts and its harness, as this may cause severe burns or electric shock and may result in injury or death. The orange connection cable is the high-voltage harness. Users are not allowed to carry out their own maintenance on the vehicle's high-voltage system. If there is any maintenance need, we

recommend you go to an authorized dealer for maintenance.

### ATTENTION

- Vehicles should be placed in dry locations, and parking in damp or wet parking areas should be avoided.
- Vehicles should avoid being placed in a high-temperature environment for a long period of time, so as not to affect the safety and service life of the battery.
- To ensure the safety of the power battery, the vehicle should be parked away from flammable and explosive items, away from fire sources, and various hazardous chemicals.
- The available battery level of the power battery will decrease as the vehicle usage time increases.
- Park should be kept away from heat sources and avoid prolonged exposure to sunlight, otherwise it will reduce the service life of the power battery.
- Before the vehicle is parked for a long period of time, please ensure the battery level is within a relatively sufficient range (50%~80%). Maintenance must be performed once every 1 month. The specific operation is: fully charge the power battery and then discharge it to 80%. Failure to operate according to the specifications may cause over-discharge of the power battery, reduce the performance of the power battery, or even cause damage, which may lead to serious faults and damage to vehicle components, and will not be covered by the warranty.
- If the battery level is discharged to 0%, be sure to charge the vehicle immediately. At this point, charging speed may be slow until the power battery's battery level reaches 20% to restore battery performance. If the power battery is not charged in a timely manner within 24 hours, it may cause irreversible damage to the power battery, resulting in serious faults and damage to vehicle parts, which will not be covered under warranty. If you are unable to charge the vehicle, please contact the authorized dealer immediately.

## POWER BATTERY RECYCLING

When the power battery reaches the end of its life, recycle the power battery in accordance with local regulations.

### ⚠ WARNING

- Do not tap, move, or disassemble the power battery and its corresponding wiring privately to avoid personal injury.

### ♻ ECO

- Please do not casually handle or discard used power batteries to avoid causing serious pollution to the environment.

## FUSE

### FUSE INSTRUCTIONS

The vehicle's fuse is designed to prevent the harness from being damaged by short circuits or overloads. These fuses are installed in four fuse boxes, namely the front compartment fuse box, the battery positive fuse box, the instrument panel fuse box, and the rear compartment fuse box.

When it is necessary to check and replace fuses, make sure the vehicle is powered off.

### CHECK FUSE

If you suspect a fuse is faulty, refer to the fuse position distribution diagram and use fuse pliers to remove it from the fuse box for inspection.

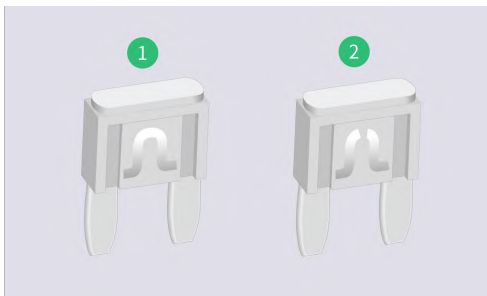

1. Normal fuse
2. Blown fuse

### 🔑 NOTE

- Check whether the metal wire inside the fuse is blown. If it is blown, it should be replaced.
- The fuse clips are placed in the front compartment fuse box.

## REPLACE THE FUSE

If you cannot determine whether the fuse is blown, you can replace the possibly faulty fuse with a normal spare fuse.

If a fuse blows, a new fuse should be installed in the fuse box, and only fuses with the same current rating as on the fuse box cover should be installed.

### ⚠ ATTENTION

- Do not use a fuse higher than the rated current or any other object in place of the fuse, otherwise it will cause serious damage to the electrical system and may result in a fire.
- The fuse box must be kept clean and protected from moisture.
- Do not attempt to repair a fuse that has already blown and continue to use it, otherwise a fire may occur due to cable overload.
- If the correct fuse is replaced and still blows after a short period of time or the electrical parts do not return to normal operation, it indicates that the vehicle may have a serious electrical system fault. At this point, you should contact an authorized dealer.

## FUSE BOX IN FRONT COMPARTMENT

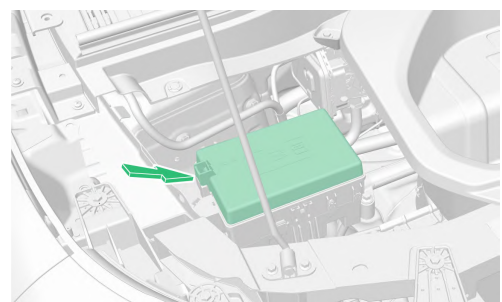

The front compartment fuse box is located on the right side of the front compartment. Open the bonnet, press the latch in the direction of the arrow, open the fuse box cover in the front compartment outward to check and replace the fuse.

### INSTRUMENT PANEL FUSE BOX

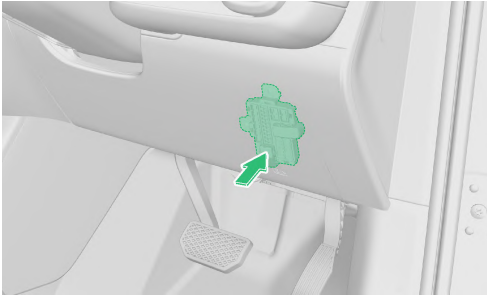

The instrument panel fuse box is located on the driver's side of the instrument panel. Remove the lower right instrument panel cover plate to check and replace the fuse.

### FUSE BOX IN THE REAR COMPARTMENT



The rear fuse box is located under the rear seat cushion. Remove the rear seat cushion to check and replace the fuse.

### BATTERY POSITIVE TERMINAL FUSE BOX

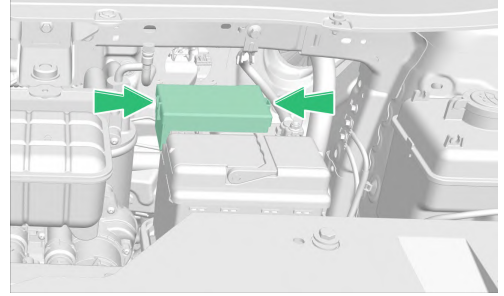

The battery positive terminal fuse box is located at the battery positive terminal in the front compartment. Open the bonnet, remove the front engine compartment storage box\*, press the latch in the direction of the arrow, and remove the cover of the battery positive fuse box to check and replace the fuse.

## FRONT COMPARTMENT FUSE POSITION DISTRIBUTION

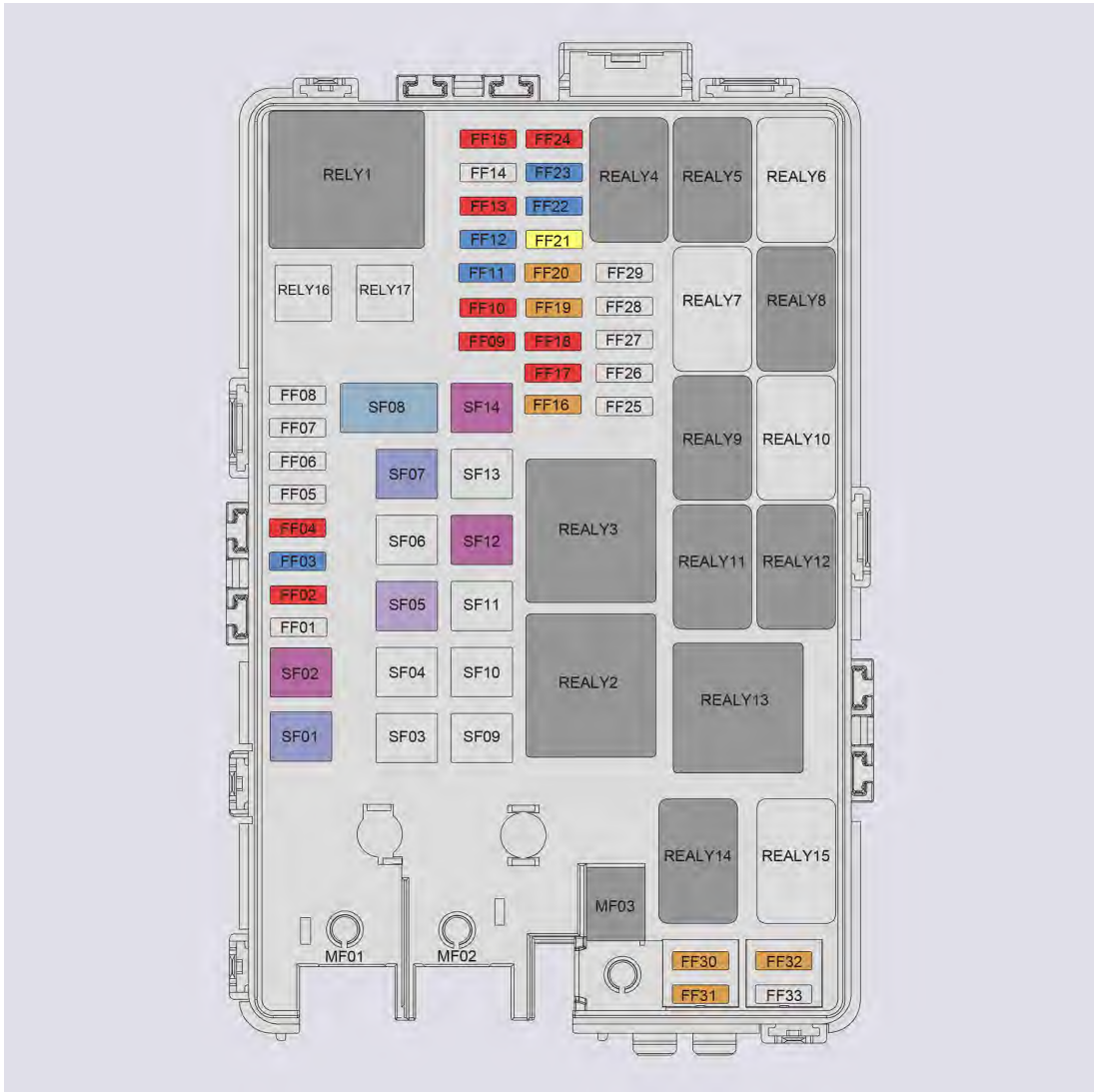

## FUSE DETAILS

Fuse Number	Fuse Specification	Fuse Name
MF03	80A	Integrated MCU power fuse
SF01	40A	Electric fan assembly (medium speed) power fuse
SF02	30A	Electric fan assembly (low speed) power fuse
SF03	—	—

Fuse Number	Fuse Specification	Fuse Name
SF04	—	—
SF05	25A	ON2C Relay Fuse
SF06	—	—
SF07	40A	A/C blower power fuse
SF08	60A	Electric fan assembly (high speed) power fuse
SF09	—	—
SF10	—	—
SF11	—	—
SF12	30A	ON2B Relay Fuse
SF13	—	—
SF14	30A	Rear Defrost Power Fuse
FF01	—	—
FF02	10A	Stop lamp switch assembly power fuse
FF03	15A	Left front combination lamp power fuse
FF04	10A	Front Fog Lamp Fuse
FF05	—	—
FF06	—	—
FF07	—	—
FF08	—	—
FF09	10A	Power Battery Management System (BMS) Power 1 Fuse
FF10	10A	Thermal management controller power fuse
FF11	15A	Horn Fuse
FF12	15A	Right front combination lamp power fuse
FF13	10A	ON3 Relay Fuse
FF14	—	—
FF15	10A	Power Battery Management System (BMS) Power 2 Fuse

Fuse Number	Fuse Specification	Fuse Name
FF16	5A	Blind Spot Detection Radar Fuse
FF17	10A	DSP Three-Way Valve / Compressor / Thermal Management - Integrated Module ON2B Power Fuse
FF18	10A	Thermal Management Controller ON2B Power Fuse
FF19	5A	Multi-Zone Integrated Control Unit/Brake Switch ON2B Power Fuse
FF20	5A	Thermal Management Relay Coil ON2B Power Fuse
FF21	20A	Oil Pump Motor ON2B Power Fuse
FF22	15A	Thermal Management Integrated Module - Motor Water Pump Fuse
FF23	15A	Thermal Management Integrated Module - Battery-Powered Water Pump Fuse
FF24	10A	Thermal Management Integrated Module - Five-Way Valve Fuse
FF25	—	—
FF26	—	—
FF27	—	—
FF28	—	—
FF29	—	—
FF30	5A	Integrated Motor Controller ON3 Power Fuse
FF31	5A	Smart Integrated Brake System Assembly ON3 Power Fuse
FF32	5A	Alcolock Control Unit Fuse
FF33	—	—

## RELAY DETAILS

Relay Number	Relay Name	Relay Number	Relay Name
RELY1	High-Speed Fan Relay	RELY10	ON2C relay

Relay Number	Relay Name	Relay Number	Relay Name
RELY2	Water pump relay	RELY11	Horn relay
RELY3	Blower relay	RELY12	Low-Speed Fan Relay
RELY4	Rear Defrost Relay	RELY13	Medium-speed fan relay
RELY5	Front fog lamp relay	RELY14	Blind Spot Detection Radar Relay
RELY6	—	RELY15	—
RELY7	—	RELY16	—
RELY8	ON2B Relay	RELY17	—
RELY9	ON3 Relay		

### INSTRUMENT PANEL FUSE POSITION DISTRIBUTION

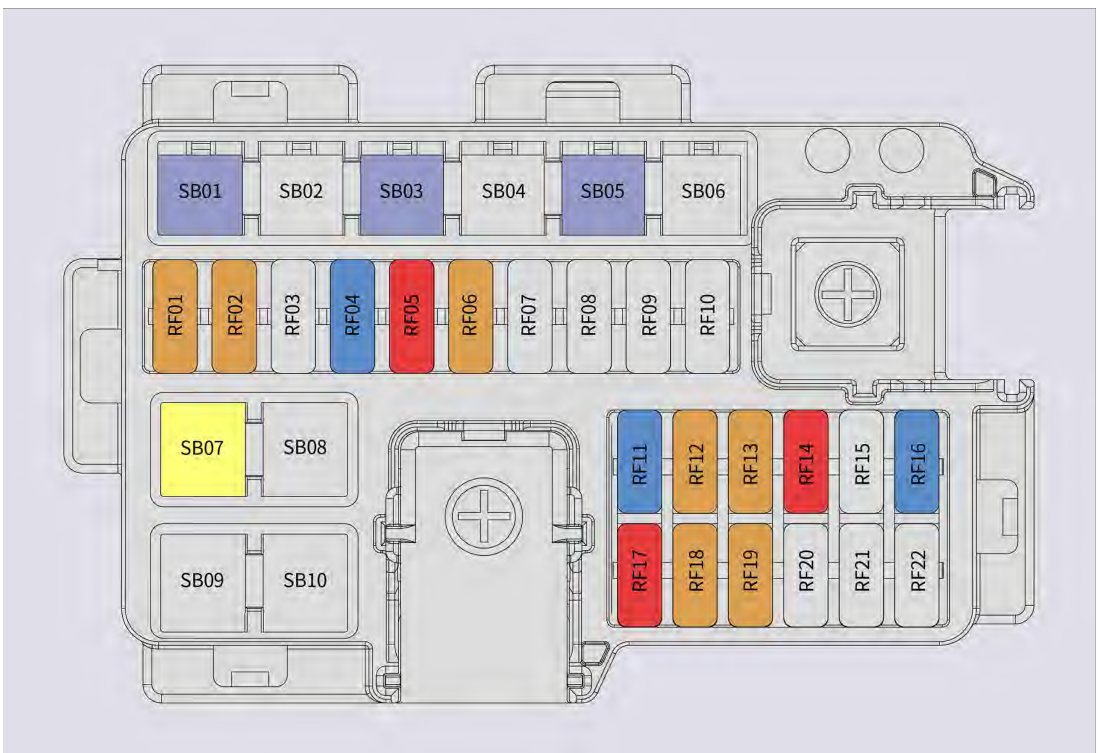

### FUSE DETAILS

Fuse Number	Fuse Specification	Fuse Name
SB01	40A	Main Zone Control Unit Power 1 Fuse

Fuse Number	Fuse Specification	Fuse Name
SB02	—	—
SB03	40A	Main Zone Control Unit Power 2 Fuse
SB04	—	—
SB05	40A	Main Zone Control Unit Power 3 Fuse
SB06	—	—
SB07	20A	Multi-Zone Integrated Control Unit Power Fuse
SB08	—	—
SB09	—	—
SB10	—	—
RF01	5A	Airbag Control Unit Assembly ON3 Power Fuse
RF02	5A	Multi-Zone Integrated Control Unit (ON3 Feedback) Fuse
RF03	—	—
RF04	15A	Backup Power – Front ON2C Power Fuse
RF05	10A	Wireless Charging/Rear Seat USB ON2C Power Fuse
RF06	5A	Front-View Monocular Camera Assembly/Multi-Zone Integrated Control Unit (ON2C Feedback) ON2C Power Fuse
RF07	—	—
RF08	—	—
RF09	—	—
RF10	—	—
RF11	15A	Smart Cockpit Host Power 1
RF12	5A	Rain/Light Sensor Power Fuse
RF13	5A	NFC Power Fuse
RF14	10A	TCU (telematics control unit) power fuse
RF15	—	—

Fuse Number	Fuse Specification	Fuse Name
RF16	15A	Diagnosis Interface Power Fuse
RF17	10A	Front USB Port Power Fuse
RF18	5A	Vital Signs Detection Radar / Front-View Monocular Camera Assembly Power Fuse
RF19	5A	DAB Host Assembly Power Fuse
RF20	—	—
RF21	—	—
RF22	—	—

### REAR COMPARTMENT FUSE POSITION DISTRIBUTION

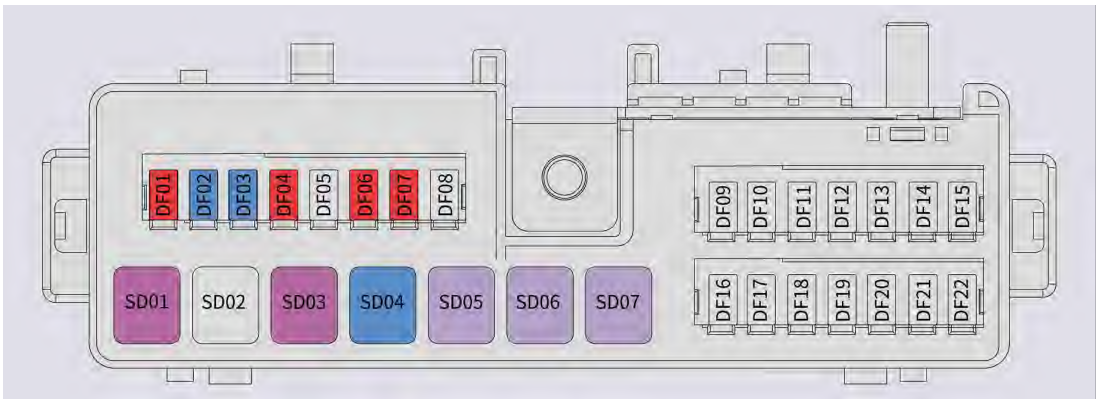

Fuse Number	Fuse Specification	Fuse Name
SD01	30A	Front Passenger Seat Adjustment Power Fuse*
SD02	—	—
SD03	30A	Driver Seat Adjustment Power Fuse*
SD04	20A	Power Sunshade Power Fuse
SD05	25A	Power Amplifier (Host Power 1 Input) Power Fuse*
SD06	25A	Electric Liftgate Drive Fuse*
SD07	25A	Power Amplifier (Host Power 2 Input) Power Fuse*
DF01	10A	Alcolock Control Unit Fuse

Fuse Number	Fuse Specification	Fuse Name
DF02	20A	Towing hook harness interface (power supply 1) fuse
DF03	20A	Towing hook harness interface (power supply 2) fuse
DF04	10A	2-in-1 power assembly/charging protocol converter power fuse
DF05	—	—
DF06	10A	Power Tailgate Controller Power Fuse*
DF07	10A	Rear e-powertrain power fuse
DF08	—	—
DF09	—	—
DF10	—	—
DF11	—	—
DF12	—	—
DF13	—	—
DF14	—	—
DF15	—	—
DF16	—	—
DF17	—	—
DF18	—	—
DF19	—	—
DF20	—	—
DF21	—	—
DF22	—	—

## BATTERY POSITIVE TERMINAL FUSE POSITION DISTRIBUTION

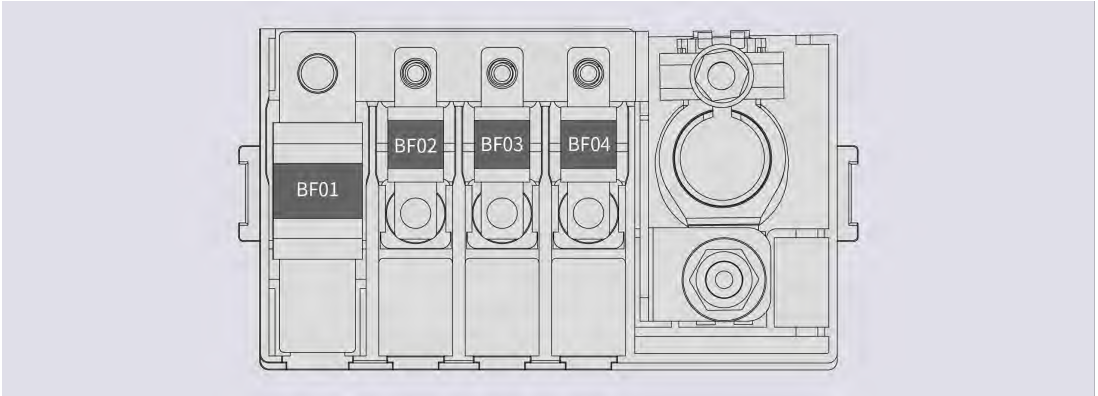

Fuse Number	Fuse Specification	Fuse Name
BF01	250A	Connected to the front compartment fuse box power supply
BF02	100A	Connected to the instrument panel fuse box power supply
BF03	60A	Smart Integrated Brake System Assembly Power 1 Fuse
BF04	60A	Smart Integrated Brake System Assembly Power 2 Fuse

## WIPER BLADE

### TURN ON THE WIPER MAINTENANCE FUNCTION

In the "Settings - System - Maintenance" screen of the infotainment screen, tap to turn on or off the front wiper maintenance function.

When the function is enabled, the front wipers move to the maintenance position. After checking and replacing the wiper blade, turn off the wiper maintenance function in the infotainment screen, and the wiper blade will return to its initial position.

### REPLACE WIPER BLADE

Replace the wiper blade as follows:

1. Turn on the front wiper maintenance function, and the front wiper blade runs to the center of the front windshield and stops.
2. Lift the wiper arm that needs to be replaced.

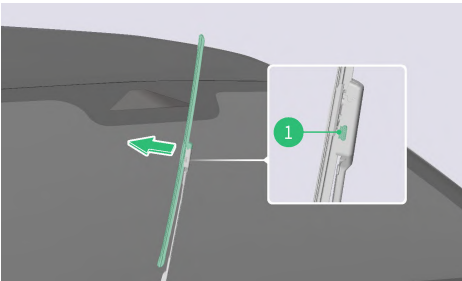

3. Press the locking buttons ① on both sides of the wiper blade, and pull out the wiper blade in the direction of the arrow.

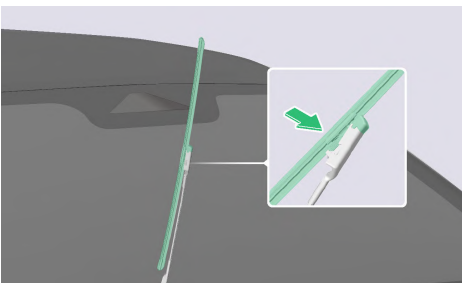

4. Push the new wiper blade in the direction shown in the illustration with force until it clicks.
5. Reset the wiper arm to the windshield.

6. Turn off the wiper maintenance function in the infotainment screen and reset the wipers to their initial positions.

#### ⚠ ATTENTION

- After replacing the wiper blade, slowly lower the wiper arm onto the windshield by hand to prevent it from falling too quickly and damaging the windshield.
- Do not allow the wiper to come into contact with gasoline, kerosene, paint thinner, or other solvents to avoid damage.
- Do not shake the wiper arm to avoid damage to the wiper arm and other parts.
- If you do not turn off the wiper maintenance function in the infotainment screen, the wipers will not work.

## BULB

### LIGHT BULB INSPECTION

The external vehicle lamps should be checked regularly. Damaged bulbs can reduce a vehicle's visibility and its ability to signal alerts to other road participants, seriously affecting driving safety.

### LIGHT BULB REPLACEMENT

The vehicle uses LED bulbs, which do not support individual replacement and require replacing the corresponding assembly parts. For replacement, it is recommended to contact the authorized dealer.

#### ⚠ WARNING

- There is pressure inside the bulb, which may explode during replacement and cause personal injury.
- Modifications or additions to external lighting and signaling devices are prohibited.

### VEHICLE LAMP FOGGING

Under certain humid conditions (such as high air humidity, car wash, etc.), the vehicle lamp cover may become fogged or even have a small amount of water droplets inside. This is caused by the temperature difference between the inside and

outside air of the vehicle lamp, similar to fogging on car windows on rainy days. It is a normal physical phenomenon and will not affect the function or service life of the vehicle lamp.

 **ATTENTION**

- If there is a large amount of water beading or pooling in the vehicle lamp housing, it is recommended that you contact an authorized dealer for check and repair.

## REGULAR MAINTENANCE

### IMPORTANCE OF MAINTENANCE

Maintenance is divided into regular maintenance and routine maintenance. Regular maintenance is performed by the authorized dealer, and routine maintenance is mainly performed by the driver. Timely regular maintenance of the vehicle is an essential part of its use.

Regular maintenance can help extend the service life of vehicles and improve driving safety. Failure to maintain the vehicle as required may lead to excessive wear of some parts, decrease in power performance, affect driving safety, increase financial expenses, and other problems.

#### **WARNING**

- Do not continue to drive a vehicle that has not been inspected, otherwise it will cause serious vehicle damage and personal injury.

### MAINTENANCE LOCATION

We recommend that you choose an authorized dealer for maintenance.

## MAINTENANCE CONTENT

Maintenance Item		Content
Power battery	Battery box	Check for irritating, burning, or other odors around the battery box.
	High and low voltage connectors and ground harnesses	Check whether the high and low voltage connectors are clean, corroded, or broken, and whether the connection is reliable; whether the ground harness is firm and not loose.
	Battery box and chassis bolt	Check the battery box (including the rear hanging beam) and vehicle chassis bolt torque, and inspect bolts for corrosion and rust.
	Exterior cleaning of undercarriage	Check the undercarriage for corrosion, deformation, etc.; check the bottom of the undercarriage for scratches, corrosion, breakage, etc.; remove dust from the undercarriage to ensure good cleanliness.
	Box air pressure balance valve and water pipe connection	Check whether the box air pressure balance valve is firm and undamaged; whether there are traces of coolant leakage or deformation at the water pipe interface.
	Battery Parameters	Check status parameters (alarm messages, fault info), SOC, temperature, cell voltage, Pack insulation resistance, software version.
	Battery pack positioning hole sealing plug	Check whether the battery pack positioning hole sealing plug is intact, dislodged, or loose.
	Battery pack nameplate and warning label	Check whether the battery pack nameplate and warning labels are missing or detached, and whether the information is complete.
Body, chassis and accessories	Exposed bolts and nuts	Check the torque of exposed bolts and nuts, and tighten them in place as specified.
	Brake pad	Check the wear of the brake pads. If the thickness of the brake pad friction material is less than 2 mm, replacement is recommended. If an alarm sound occurs, replace the brake pads immediately.
	Brake disc	Check the wear of the brake disc. If the thickness of the brake disc is less than 23 mm (front) / 8 mm (rear), replacement is recommended.
	Brake hose and hard pipe	Check brake pipeline for leaks, damage, and tightness.
	Brake fluid	Check the brake fluid level and top up with the matching DOT4 brake fluid from Leapmotor when insufficient; brake fluid must be replaced every 2 years or 40,000 kilometers (24,855 miles) of driving, and must be replaced earlier under especially severe conditions.
	Steering gear dust cover	Check the dust cover for damage and oil leakage.
	Drive shaft dust cover	Check the dust cover for damage and oil leakage.

Maintenance Item		Content
	Door, front and rear hood hinges	Check whether the fixing bolts are tight, and clean up the dust; if the movement is not smooth, oiling or adding lubricant is needed.
	Door check	Check whether the fixing bolts are tight, and clean up the dust; if the movement is not smooth, oiling or adding lubricant is needed.
	Charging port lid	Check the automatic opening speed of the charging port lid. If the automatic opening speed is slow, clear the ash layer on the charging port box. If necessary, apply oil or lubricant (spraying WD40) on the hinge part inside the charging port box.
	Tire	Check if the cold tire inflation pressure is normal, no load (front/rear wheels): 230/230 kPa, full load (front/rear wheels): 250/250 kPa; it is recommended to replace the tires when they have been driven for 3 years or 40,000 km (24,855 miles), or when the tread depth is less than 3 mm under either condition; if you find that the tires have abnormal wear, the vehicle is veering off course, or there are other abnormalities, check the wheel alignment.
	Door cover stop block, gas spring	Check and clean up the dust.
	Coolant	Check whether the coolant level is within the standard range; add coolant if it is insufficient. Replace it every 4 years or 40,000 kilometers (24,855 miles). The specification of the newly added coolant must be consistent with that of the original model.
	Wiper blade	Check the wiper blade for wear and aging; it is recommended to replace it every year of use.
Travel drive motor	Safety ground harness	Check the tightness of the safety ground harness.
	Exterior accessory fixing bolt	Check the tightness of exterior accessory fixing bolts.
	Travel drive motor	Check the torque of the travel drive motor fixing bolts, the travel drive motor vent plug, and the oil leak hole under the travel drive motor.
	Reducer	Check the reducer mating surface and draining bolt for oil leakage; check the reducer vent plug torque and oil marks on the reducer output end shell.
	Position and temperature sensors	Detect position and temperature sensors, measure sensor resistance and insulation resistance values.
	Reducer oil	Replace the reducer oil every 60,000 kilometers (37,282 miles).
	Filter	Replace the filter every 60,000 kilometers (37,282 miles).
	Assembly shell	Clean and check the travel drive motor shell; check whether the travel drive motor runs smoothly and whether there is any abnormal noise in the no-load and traveling statuses.

Maintenance Item		Content
	Control unit fixing bolt and ground harness	Check tightness of drive motor control unit fixing bolts; check the tightness of ground harness.
	High and low voltage harnesses and connectors	Check if the surface of the harness/connector is intact and undamaged, firm and not loose, and whether the cover of the harness bellow is aged, cracked or dislodged; check if the terminal bolts of the harness are loose.
Thermal management	Water cooling system pipeline	Check the water cooling system pipeline for aging, deformation, and leakage.
	Super integrated module	Check for loose clips on the super integrated module harness connector; check for leakage on the super integrated module, scale in the expansion tank, normal operation of the water pump, and leakage of oily liquid at the interface between the module body and the refrigerant pipeline and valve components.
	Cooling module	Check the radiator surface for dirt and foreign matter, and clean if necessary.
Automotive electronics	Lamp, horn, wiper, washer	Check and verify the function of all vehicle lamps, horn, wipers, and washer.
	Door, door lock	Check door and door lock function, and adjust as necessary.
	Moving part, connector and harness	Check the moving parts and the harness for interference and wear; whether the connector is properly plugged in; whether the harness is properly fixed; and measure the insulation resistance value.
	Compressor	Test the insulation resistance of the compressor; test the grounding resistance of the compressor ground cable.
	A/C system	Check whether the air conditioner is functioning properly and whether there is any leakage or abnormal noise in the refrigerant, air conditioning pipeline, or compressor.
	A/C filter element	Replace every 1 year or 20,000 km (12,427 miles). If there is an odor when using the A/C, immediately go to the authorized dealer for maintenance.
	Control unit software version	Check whether the control unit software version is the latest status, and refresh it if necessary.

For vehicles that frequently operate under the following harsh conditions, additional maintenance items or shorter maintenance intervals are required. For specific matters, contact the authorized dealer:

- Driving in dusty environments, such as construction sites, deserts, etc.
- Driving in cold (below 0°C) or hot (above 40°C) ambient temperatures.
- Driving in a damp environment or frequently wading through water.
- Driving on roads with high salt content or corrosive materials.
- Frequent rapid acceleration and deceleration in mountainous conditions.
- Used for special purposes such as taxis, operational activities, or frequent high-load use.
- Engage in racing or competitive activities.
- Additions or modifications without authorization from Leapmotor are prohibited.

 **NOTE**

- The time and mileage in the maintenance content are based on whichever comes first.

**MAINTENANCE INTERVAL TABLE**

Maintenance interval	×1,000 kilometers (621 miles)	20	40	60	80	100	120	140	160	180	200
Maintenance Item	Number of months	12	24	36	48	60	72	84	96	108	120
Power battery	Battery box	J	J	J	J	J	J	J	J	J	J
	High and low voltage connectors and ground harnesses	J	J	J	J	J	J	J	J	J	J
	Battery box and chassis bolt	J	J	J	J	J	J	J	J	J	J
	Exterior cleaning of undercarriage	J	J	J	J	J	J	J	J	J	J
	Box air pressure balance valve and water pipe connection	J	J	J	J	J	J	J	J	J	J
	Battery Parameters	J	J	J	J	J	J	J	J	J	J
	Battery pack positioning hole sealing plug	J	J	J	J	J	J	J	J	J	J

Maintenance interval	×1,000 kilometers (621 miles)	20	40	60	80	100	120	140	160	180	200	
Maintenance Item	Number of months	12	24	36	48	60	72	84	96	108	120	
	Battery pack nameplate and warning label	J	J	J	J	J	J	J	J	J	J	
Body, chassis and accessories	Exposed bolts and nuts	J	J	J	J	J	J	J	J	J	J	
	Brake pad	J	J	J	J	J	J	J	J	J	J	
	Brake disc	J	J	J	J	J	J	J	J	J	J	
	Brake hose and hard pipe	J	J	J	J	J	J	J	J	J	J	
	Brake fluid	Conduct routine inspection during each maintenance; replace every 2 years or 40,000 km (24,855 miles)										
	Steering gear dust cover	J	J	J	J	J	J	J	J	J	J	J
	Drive shaft dust cover	J	J	J	J	J	J	J	J	J	J	J
	Door, front and rear hood hinges	J	J	J	J	J	J	J	J	J	J	J
	Door check	J	J	J	J	J	J	J	J	J	J	J
	Charging port lid	J	J	J	J	J	J	J	J	J	J	J
Tire	Conduct a routine inspection during each maintenance. Recommended replacement cycle: Every 3 years or 40,000 km (24,855 miles), replace as needed.											

Maintenance interval	×1,000 kilometers (621 miles)	20	40	60	80	100	120	140	160	180	200
Maintenance Item	Number of months	12	24	36	48	60	72	84	96	108	120
Door cover stop block, gas spring	Door cover stop block, gas spring	J	J	J	J	J	J	J	J	J	J
	Coolant	Conduct routine inspection during each maintenance; replace every 4 years or 40,000 km (24,855 miles)									
	Wiper blade	Conduct routine during each maintenance; replace as necessary.									
Travel drive motor	Safety ground harness	J	J	J	J	J	J	J	J	J	J
	Exterior accessory fixing bolt	J	J	J	J	J	J	J	J	J	J
	Travel drive motor	J	J	J	J	J	J	J	J	J	J
	Reducer	J	J	J	J	J	J	J	J	J	J
	Water cooling system pipeline	J	J	J	J	J	J	J	J	J	J
	Reducer oil	Check during each maintenance; replace every 60,000 km (37,282 miles)									
	Filter	Check during each maintenance; replace every 60,000 km (37,282 miles)									
	Assembly shell	J	J	J	J	J	J	J	J	J	J
	Control unit fixing bolt and ground harness	J	J	J	J	J	J	J	J	J	J
	High and low	J	J	J	J	J	J	J	J	J	J

Maintenance interval	×1,000 kilometers (621 miles)	20	40	60	80	100	120	140	160	180	200
Maintenance Item	Number of months	12	24	36	48	60	72	84	96	108	120
	voltage harnesses and connectors										
Thermal management	Water cooling system pipeline	J	J	J	J	J	J	J	J	J	J
	Super integrated module	J	J	J	J	J	J	J	J	J	J
	Cooling module	J	J	J	J	J	J	J	J	J	J
Automotive electronics	Lamp, horn, wiper, washer	J	J	J	J	J	J	J	J	J	J
	Door, door lock	J	J	J	J	J	J	J	J	J	J
	Moving part, connector and harness	J	J	J	J	J	J	J	J	J	J
	Water cooling system pipeline and water pump	J	J	J	J	J	J	J	J	J	J
	Compressor	J	J	J	J	J	J	J	J	J	J
	A/C system	J	J	J	J	J	J	J	J	J	J
A/C filter element	Replace every 1 year or 20,000 km (12,427 miles). If there is an odor when using the A/C, immediately go to the authorized dealer for maintenance.										

Maintenance interval	×1,000 kilometers (621 miles)	20	40	60	80	100	120	140	160	180	200
Maintenance Item	Number of months	12	24	36	48	60	72	84	96	108	120
	Control unit software version	J	J	J	J	J	J	J	J	J	J

The meaning of the codes in the table:

- J: "Check, adjust, or add if necessary".

**▲ ATTENTION**

- It is recommended that vehicle maintenance be performed according to the above intervals to ensure the vehicle's optimal status. If a fault is caused by failure to maintain the vehicle properly, Leapmotor will not be responsible for warranty service.

**◆ NOTE**

- In order to keep the battery in optimal condition, fully charge and discharge the vehicle at regular intervals (at least every 6 months or 7,000 kilometers (4,350 miles)). If the vehicle is not used for a long period of time, perform slow AC charging at least once a month and charge the battery level to 100% to achieve battery self-calibration. You can also contact the authorized dealer for capacity testing and calibration.
- Time and mileage in the maintenance interval table are based on whichever comes first.

## EMERGENCY RESPONSE DEVICE

### HAZARD WARNING LAMP

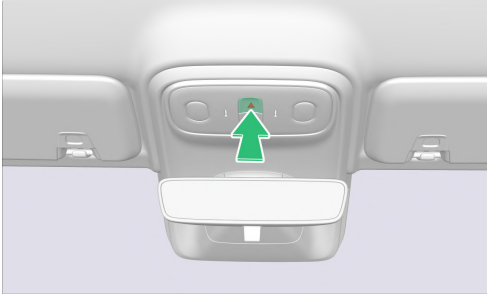

The hazard warning lamp switch is installed on the front reading light control panel of the vehicle.

Press the hazard warning lamp switch when the vehicle malfunctions or encounters a dangerous situation. The red background light of the switch will flash. At the same time, the left and right direction indicator lamps and the left and right turning indicators in the instrument cluster will flash synchronously. Press the hazard warning lamp switch again, the red background light will go out, and the hazard warning lights will be turned off.

Turn on the hazard warning lamp in the following cases:

- The vehicle broke down due to a fault.
- When the vehicle gets stuck in traffic on a highway or urban expressway, it is at the end of the traffic flow.
- When the vehicle is being towed, etc.

#### **WARNING**

- If the hazard warning lamp is inoperative, other methods must be taken to attract the attention of other road users, and such methods must comply with relevant traffic regulations.

### E-CALL EMERGENCY ASSISTANCE\*

In the event of a traffic incident (front collision, side collision, rear collision, rollover, etc.) or when the user presses the SOS button, the emergency assistance center can be connected, and the MSD

(Minimum Data Set) will be transmitted to the service center through the voice dialing channel. The service center will then promptly contact the local 4S shop, medical rescue center, police station, and other relevant agencies according to the vehicle's related information, and arrive at the incident scene to provide rescue.

#### **ATTENTION**

- The service centers connected by the e-Call function are not available in all areas.
- e-Call communicates via the cellular network.

### USE E-CALL

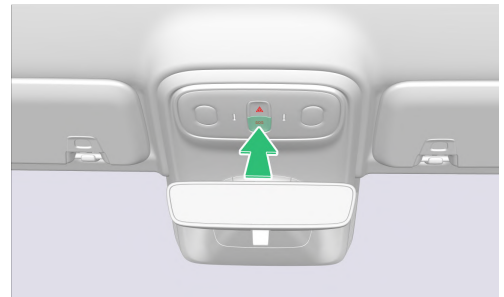

e-Call will be triggered automatically in the event of an airbag deployment or vehicle rollover.

Alternatively, it can be triggered manually by pressing the SOS button on the vehicle roof of (e-Call will be triggered 2s after the button is pressed).

#### **NOTE**

- The e-Call function can be manually triggered in the event of a serious incident, and it can also be used in emergency situations inside the vehicle (for example, a sudden heart attack).

### ATTACHED TOOLS

The attached tools are placed under the trunk carpet.

## TYPES OF ATTACHED TOOLS

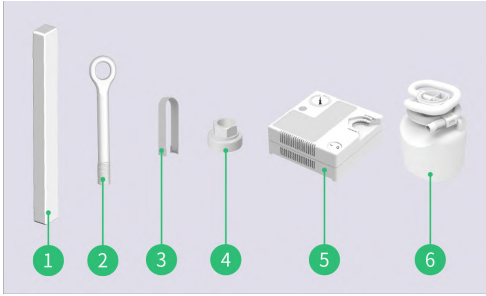

1. Warning triangle
2. Towing hook
3. Nut trim cover removal clip
4. Security lug nut socket\*
5. Inflation pump
6. Tire sealant

### NOTE

- To respond to various emergency situations, you should be familiar with the positions and use methods of attached tools. After use, tools should be cleaned promptly and placed back in their original positions.
- The anti-theft sleeve\* has multiple statuses; the illustration is for reference only. Please refer to the actual vehicle.

## WARNING TRIANGLE

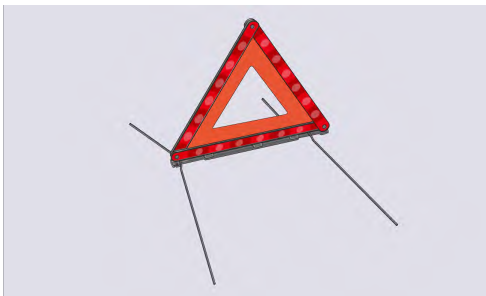

The warning triangle is stored inside the trunk. Take it out of the attached toolbox and unfold it to use.

### NOTE

- Please use the warning triangle correctly according to the corresponding national laws and regulations.
- On general roads, drivers should place warning triangles 50m (daytime)/80m (nighttime) away from the direction of incoming traffic; on highways, warning triangles should be placed 150m away from the direction of incoming traffic. Special attention should be paid to some special circumstances, such as rainy days or at turns. A warning triangle sign should be placed 150 meters ahead of the vehicle's direction of travel to alert the vehicles behind in advance.

## REFLECTIVE VEST

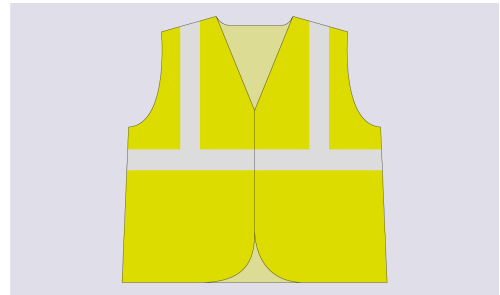

If you have to get out of the vehicle to check or handle vehicle faults during driving, especially at night, take out the reflective vest from the glove box and wear it properly before getting off the vehicle to check or handle vehicle faults, so as to attract attention from the rear vehicles.

### WARNING

- When handling a vehicle incident, regardless of the lighting conditions, be sure to wear a reflective vest as required to attract the attention of pedestrians or other drivers.

### NOTE

- After using the reflective vest, please store the reflective vest properly in the glove box.
- If the reflective vest is torn or badly soiled, it is recommended that you replace it with a new reflective vest in a timely manner.

## CAR EMERGENCY HAMMER

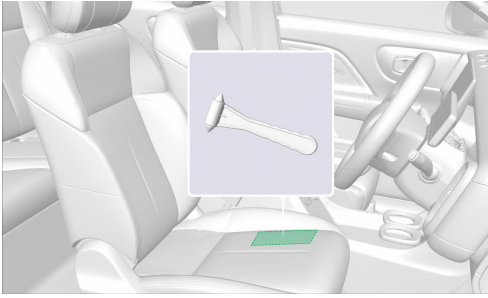

A car emergency hammer is placed under the driver's seat. When in an emergency (and the car window cannot be raised or lowered), use a car emergency hammer to break the window and escape.

How to use a car emergency hammer:

1. Find the fragile point at the edge of the car window.
2. Hold the hammer handle and strike the fragile point hard.
3. Repeatedly strike until the car window breaks.

### ⚠ ATTENTION

- Use it only in emergency situations.
- Take care to protect your own safety when knocking.
- Normally, the car emergency hammer should be placed in an easily accessible location.
- Please use the car emergency hammer properly to ensure safe travel.

## ACCIDENT HANDLING

### TIRE BLOWOUT

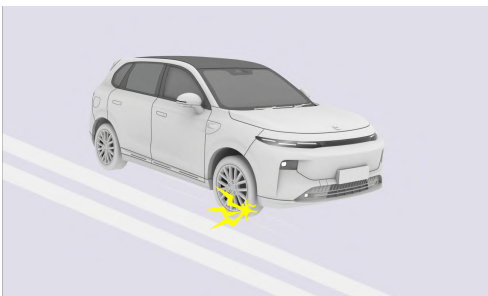

When the vehicle is in motion and a tire blowout occurs, hold the steering wheel tightly with both hands, gently press the brake pedal, and slowly slow down the vehicle to travel in a straight line in the original direction. After slowly driving to a safe position, stop the vehicle and wait for rescue.

### ⚠ WARNING

- Do not slam the brake pedal, as this may cause the vehicle to lose its center of gravity and lose control or roll over.
- Promptly turn on the hazard warning lamp and place a warning triangle at the rear of the vehicle as required to alert vehicles behind you and avoid danger.

### TIRE FLAT

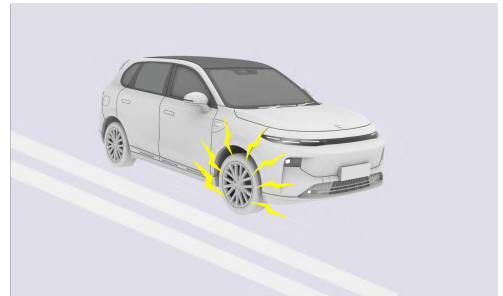

When you find that the tire is leaking air, you should gently press the brake pedal, slowly slow down, keep driving in a straight line, drive the vehicle off the road to a safe place, stop and wait for rescue.

### ⚠ WARNING

- When waiting for rescue, turn on the hazard warning lamp and place a warning triangle at the rear of the vehicle as required to alert the vehicles behind you and avoid danger.

### ⚠ ATTENTION

- Do not continue driving with a leaking tire; even driving a short distance will cause the tire to be damaged beyond repair.

## VEHICLE TRAPPED

If the vehicle is stuck on a soft surface such as sand, mud, or snow, follow these steps to get out of the pit:

1. Turn the steering wheel from side to side to grind an area around the front wheels and remove any mud, snow, or sand trapped around the tires.
2. Place wooden blocks, stones, or other materials to help increase tire friction.
3. Start the vehicle and accelerate carefully to get the vehicle out of the trap.

### ⚠ ATTENTION

- During acceleration, human assistance can be used in conjunction with forward and backward pushing methods to move the vehicle out of the pit, ensuring that the surrounding area is spacious and clear to avoid hitting other vehicles, objects, or people. The vehicle may suddenly accelerate sharply forward or backward as it is about to exit the pit. Please be sure to pay attention to the surroundings of the vehicle.
- If you still can't get out of the pit after several attempts, you will need tow truck assistance.

## TIRE INFLATION

The vehicle is equipped with an inflation pump to timely inflate the tires when the tire pressure is insufficient.

The usage of the inflation pump is as follows:

1. Remove the air nozzle cap by turning it counterclockwise.
2. Screw the inflation pump connector into the tire air nozzle. During screwing, if you hear a slight air leakage sound from the air nozzle, it indicates that air is flowing. Continue screwing until there is no leakage sound.
3. Plug the power plug of the inflation pump into the onboard power supply interface.
4. Start the vehicle, press the inflation pump power switch, and begin inflation.
5. Keep an eye on the air pressure gauge for change, and when the desired tire pressure is reached, turn off the power switch to stop working.

### ⚠ WARNING

- Please park the vehicle in a flat and safe place before starting to inflate and repair the tire.
- Do not disassemble or modify the inflation pump.

### ⚠ ATTENTION

- Please use DC12V power supply, and do not use other power supplies.
- Do not operate the inflation pump for more than 30min.
- Do not operate the inflation pump submerged in water when it is raining.
- Inhaling sand and dust may cause a fault; do not use it directly on sandy or dusty surfaces.

## TIRE REPAIR OPERATION

The vehicle is equipped with a tire repair device to handle flat tire and other faults in emergencies.

The tire repair device cannot be used to repair the tire in the following situations:

1. The tire is damaged.
2. The side of the tire is damaged.
3. The wound surface due to puncture by a sharp object is larger than 6mm.
4. The hub is damaged.

### 🔑 NOTE

- For specific instructions on how to use the tire repair device, please refer to the illustrated steps affixed to the surface of the product.

## VEHICLE TOWING

If the vehicle needs to be towed, it should be towed by the authorized dealer or a professional towing company.

When a vehicle breaks down and needs to be towed, choosing a flatbed trailer is the best option, as the front or rear wheels touching the ground may cause damage to some high-voltage components.

### Platform trailer

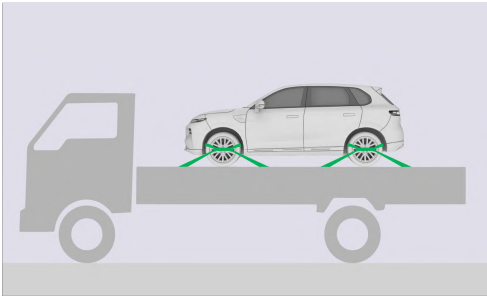

### Wheel lift trailer



If a wheel lift trailer is used to tow a vehicle from the front of the vehicle, a towing trolley should be used under the rear wheels.

#### NOTE

- All towing must use a safety chain system and comply with relevant national/provincial (municipal) and local legal requirements and industry standards.

## EMERGENCY TOWING

In case of emergency, if a platform trailer or wheel lift trailer cannot be used, a trailer cable or trailer chain can be fastened to the tow hook at the front of the vehicle to temporarily tow it. This method is only suitable for low-speed, short-distance towing on solid and flat road surfaces.

### Front towing

Front towing hook installation method:

1. Remove the towing hook from the trunk attached tool storage area.



2. Open the towing hook cover plate by levering the front towing hook cover plate located on the lower right side of the front of the vehicle in the direction shown.

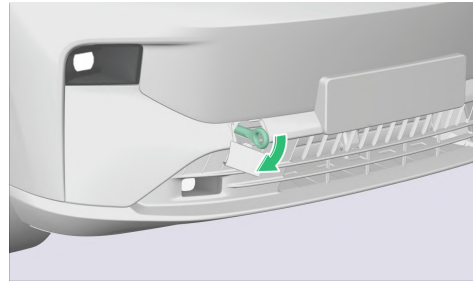

3. Screw the towing hook clockwise into the towing hook mounting hole and tighten.

#### WARNING

- Tighten the towing hook when installing it on the vehicle. If the towing hook is loose, it could come off while towing and result in serious injury to a person or damage to the vehicle.
- If the vehicle is stuck in silt or sand, or if it is necessary to use a towing hook to pull the vehicle out due to other circumstances, be sure to observe the above precautions; otherwise, the tow cable may break due to excessive force applied, which could result in serious personal injury and vehicle damage.
- The emergency towing method is only applicable for temporarily extricating a vehicle in an emergency status or towing it onto a flatbed trailer.

#### ATTENTION

- Before towing, be sure to check the towing hook for breakage or damage.

- When towing, try to tow in a straight line. Do not tow from the side or at a vertical angle to avoid damaging the towing hook.
- Do not pull the towing hook hard; apply force smoothly and evenly.
- If it is difficult to move the tow truck, do not continue to force it and contact the authorized dealer.

### EXTERNAL TRAILER\*

The vehicle towing assembly is a spherical coupling complying with the ECRR55 regulation, which can support towing accessories (such as trailers, recreational vehicles, bicycles, etc.).

Towing a trailer and carrying accessories will increase vehicle weight and drag; therefore, the range may be significantly reduced when towing. Although the vehicle mileage calculator attempts to adjust the mileage estimate based on the installation of brackets, actual energy consumption may vary, and trip length and destination need to be reasonably planned before traveling.

To install and use the bracket, the towing device must be connected. Follow the instructions provided with the bracket and comply with all local regulations and legal requirements applicable to carrying accessories.

When towing an accessory, periodically verify that the bracket and its cargo are always in a safe status, and also verify that the signal light on the accessory works properly (if any).

#### WARNING

- Do not install a bracket on vehicles without a towing component.
- When loading and towing, comply with applicable local laws and regulations.

#### ATTENTION

- The towing device may block the view of the rearview mirror and rear camera, affecting the perception of rear ultrasonic sensors. In addition, certain advanced driver-assistance system (ADAS) functions may not operate properly.

#### NOTE

- Before departure, the working condition of all trailer lights should be checked.
- Make sure the trailer ball is securely fixed.

### TRAILER MODE

The user manually turns on the trailer mode:

1. When the vehicle is completely stationary, the gear is in the "P" position, and a trailer is attached to the towing hook.
2. On the "Settings - System - Safety" interface of the infotainment screen, tap the "Trailer Mode On" button, and a secondary confirmation pop-up will appear.
3. After confirmation, trailer mode will be enabled, and the "Trailer" icon will be displayed on the top bar of the infotainment screen, indicating that trailer mode is active. Some smart driving functions will be unavailable, and the reversing radar alarm sound will be disabled.

The user manually turns off the trailer mode:

1. When the vehicle is completely stationary, shift it into P gear.
2. On the "Settings - System - Safety" interface of the infotainment screen, tap the "Trailer Mode Off" button, and a secondary confirmation pop-up will appear.
3. After confirmation, trailer mode will be turned off, and the "Trailer" icon on the top bar of the infotainment screen disappears, indicating that trailer mode has been turned off. At the same time, the smart driving function switch is restored to the status before trailer mode was turned on.

Trailer mode is automatically turned on:

1. When a trailer is attached to the towing hook but trailer mode is not activated, trailer mode will be automatically activated. A pop-up box on the infotainment screen will remind you. Tap to confirm, the pop-up box will disappear, and trailer mode will be enabled.
2. After turning on trailer mode, the "Trailer" icon will be displayed on the top bar of the infotainment screen, indicating that trailer mode is active. Some smart driving functions will be unavailable, and the reversing radar alarm sound will be disabled.

#### ATTENTION

- After turning on trailer mode, the smart driving switch is grayed out but the switch status remains unchanged. Tapping it cannot control the smart driving switch, and a pop-up window reminds you: Please turn off trailer mode first.
- When the vehicle is not in Park (P) or is not completely stationary, tapping the trailer mode on/off button will prompt that enabling/disabling trailer mode has failed.
- Automatically turns off each time power is turned off and performs automatic opening logic based on the towing hook signal each time power is turned on.

#### NOTE

- After trailer mode is automatically enabled, it can still be manually turned off.
- When the towing hook is not installed, trailer mode cannot be manually turned on.

## TOWING CAPACITY

The maximum towing capacity (including all cargo and additional equipment) must not exceed 750 kg. The maximum vertical load capacity of towing hook shall not exceed 30kg.

#### WARNING

- Do not allow the vehicle to tow beyond the maximum load capacity to avoid causing damage to the vehicle.
- Loading weights in excess of the maximum load capacity can adversely affect vehicle stability and braking performance, leading to loss of vehicle control and increased braking distances, resulting in serious incidents.
- When calculating the load capacity of the rear bearing, it is essential to add together the load on the tow hook, the load in the trunk, and the weight of the occupants in the rear seats.

## TIRE PRESSURE WHEN TOWING

When towing, tire pressure must be adjusted to accommodate the additional load. Keep tires inflated to 250 kPa, and when towing, the maximum allowable upslope is 12%.

#### ATTENTION

- Never attempt to tow the vehicle when the vehicle has a tire fault. Temporarily repaired tires cannot withstand towing loads. Towing with faulty or temporarily repaired tires may result in tire fault and loss of vehicle stability.

## PRE-TOWING OPERATIONS

The following operations must be performed before towing:

- Before towing, inflate the tires to the cold tire inflation pressure specified for towing.
- Understand and comply with all local laws and regulations regarding towing.
- Adjust the rearview mirror to ensure there are no obvious blind spots.

Please confirm the following before towing:

- Towing vehicle drivers must hold a driver's license that complies with local regulations.
- The vehicle must be positioned horizontally when connecting the trailer hitch. If the vehicle tilts upwards at the front and downwards at the rear, confirm that the maximum towing capacity and the maximum vertical load capacity of the towing hook provided in the "Towing Capacity" section are not exceeded.
- All trailer parts, accessories, and electrical connectors are in good status and properly connected. If there are any obvious problems, do not tow the vehicle.
- The trailer tongue is securely connected to the tow ball assembly.
- All cargo has been secured.
- The vehicle stopper is available.
- The trailer load is evenly distributed so that the trailer tongue weight is around 4% of the total trailer weight and does not exceed the maximum towing hook vertical load capacity provided in the "Towing Capacity" section.

#### WARNING

- Always ensure the cargo is secured in the trailer and will not move. Dynamic load movement of the vehicle can cause loss of vehicle control, resulting in serious injury or even life-threatening injury.
- The trailer tongue weight must be about 4% of the gross trailer weight and not exceed the maximum towing hook vertical load capacity provided in the "Towing Capacity" section.

- Unbalanced loads on the wheels or heavier loads in the rear may cause the trailer to sway, resulting in the vehicle losing control.
- The towing weight shall not exceed the vehicle gross weight, maximum rear axle mass, and maximum trailer mass.
  - After loading, the towing trailer should be parallel to the ground.

2. Others place the stoppers under the wheels on the downhill side of the vehicle.
3. When the stoppers are in place, release the brake pedal and ensure the stoppers can support the weight of the vehicle and trailer (Auto Hold function not activated).
4. Shift the vehicle into P gear to enable electronic parking brake.

## TOWING INSTRUCTIONS

The vehicle is mainly designed as a passenger vehicle. Towing a trailer puts additional loads on the vehicle's motor, transmission, brakes, tires, and suspension, and significantly reduces mileage. If you need to tow a trailer, operate with caution and follow the guidelines below:

- Reduce driving speed and avoid sudden maneuvers. Steering, stability, turning radius, stopping distance, and braking performance are all different when towing a trailer compared to driving without a trailer.
- Avoid sharp turns, as sharp turns may cause the trailer to contact the vehicle and cause damage. Trailer wheels are closer to the inside of the turn than vehicle wheels; therefore, the turn should be wider to prevent the trailer from hitting curbstones, road signs, trees, or other objects.
- Maintain at least twice the required distance from the vehicle ahead to increase the following distance, which helps avoid situations requiring emergency braking. Sudden braking may cause skidding, bottom scratches, and loss of control.
- Regularly confirm whether the cargo is secure.
- Periodically verify that the trailer brake is working properly.
- Avoid parking on slopes.
- Periodically verify that all towing components are securely tightened.
- No persons are allowed to be on board in the trailer while it is being towed.
- Place heavy objects in the trailer as close to the axle as possible to reduce interference with the vehicle during swinging.

### **WARNING**

- If you need to park on a slope, always make sure that all trailer wheels are firmly secured with stoppers, otherwise it may cause serious damage to the vehicle, injury, or even be life-threatening.

## TRAILER PARKING

It is recommended that the vehicle be parked on a level surface with a slope not exceeding 12%. If you must park on a slope, place wheel stoppers under the trailer wheels:

1. The driver presses down and holds the brake pedal.

## ELECTRICAL CONNECTIONS

Trailers usually come with tail lamps, stop lamps, side indicators and direction indicator lamps. To provide power to the trailer lighting system, the vehicle is fitted with a built-in 13 pin electrical connector in the lower rear bumper.



Pin number	Functions	Pin number	Functions
1	Left direction indicator lamp	2	Rear fog lamp
3	Ground wires for pins 1-2 and 4-8	4	Right direction indicator lamp
5	Right rear width indicator	6	Stop lamp

Pin number	Functions	Pin number	Functions
7	Left rear width indicator	8	rear reversing lamp
9	12V power supply	10	12V ACC power cord
11	Ground wire for pin 10	12	Spare contacts, electromagnetic brakes, etc.
13	Ground wire for pin 9		

**⚠ ATTENTION**

- Do not attempt to splice directly or try to connect the trailer's wires using any other method, as this could damage the vehicle's electrical system and cause a fault.

**🔑 NOTE**

- Before and during towing, it is necessary to check and ensure that all electrical connections are in working order and that all trailer vehicle lamps are working properly.
- Be sure to ensure that trailer wires do not contact or drag on the ground, and leave enough wire slack for turning.

## JUMP STARTING

If the low voltage battery is drained, try starting your vehicle with another vehicle and jumper cables.

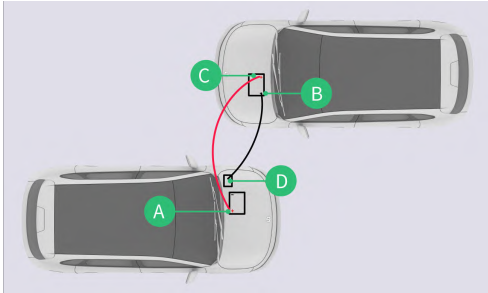

Connect the cable as follows:

1. Connect one end of the red positive (+) cable to the positive (+) terminal (A) of the dead battery.
2. Connect the other end of the red positive (+) cable to the positive (+) terminal (C) of the charged battery.
3. Connect one end of the black negative (-) cable to the negative (-) terminal (B) of the charged battery.
4. Connect the other end of the black negative (-) cable to the unpainted metal part (D) of the vehicle with dead battery.
5. Start the vehicle with charged battery, and allow the vehicle to be powered on for a while.

### ⚠ ATTENTION

- Do not allow the cable terminals to come into contact with any objects other than the connection points.
- Do not connect the other end of the black negative (-) cable to the dead battery.
- Attempt to start the vehicle with dead battery. If it fails to start after several attempts, the vehicle is likely to require check and repair, and it is recommended that the vehicle be taken to the authorized dealer for servicing. In particular, never connect the battery negative terminals to each other during jump starting.
- When starting the vehicle via jumper cables, the two vehicles should not come into contact with each other, otherwise, once the positive terminals of the low-voltage batteries of the two vehicles are connected,

the current may be conducted immediately, causing damage to the vehicle.

Disconnect the jumper cable as follows:

1. Disconnect the black negative (-) cable on the vehicle with dead battery.
2. Disconnect the black negative (-) cable on the vehicle with charged battery.
3. Disconnect the red positive (+) cable on the vehicle with charged battery.
4. Disconnect the red positive (+) cable on the vehicle with battery dead.

### ⚠ WARNING

- If jumper cables are connected or disconnected in the wrong order, electrical short circuits may occur and damage the vehicle, and the resulting repairs will not be covered by the warranty. Therefore, be sure to connect or disconnect jumper cables in the correct order and ensure that the cables do not tap each other or other metals.

## EMERGENCY RESPONSE PLAN

### EMERGENCY RESPONSE TO FIRE

Vehicle fires are handled as follows:

1. After a vehicle fire, pull over at the first opportunity and turn off all power supply systems to the vehicle.
2. Verify the location of the fire on the vehicle. After the open flame ignites, do not touch the fire source with your hands to avoid burns. It is strictly prohibited to use water or other conductive materials to extinguish the fire, to prevent electrocution or secondary damage to the vehicle's internal systems.
3. Use a fire extinguisher to spray at the base of the fire and the crevices of the vehicle, or use roadside dirt and sand to cover the fire source, isolating the ignition point from the air.
4. Make a correct judgment of the fire danger, abandon the vehicle if necessary, and maintain a sufficient safety distance.

### ⚠ WARNING

- When the vehicle catches fire spontaneously, there is a possibility that the battery may

explode. If the fire becomes too large to control, please evacuate the scene decisively and call the police.

- Do not touch any part of the car directly; it should be operated by professional rescuers wearing the correct protective equipment, and the trapped occupants inside the car should be evacuated according to the guidance of professional rescuers.
- Under the premise of ensuring personnel safety, the fire should be controlled at the first opportunity to try to avoid the vehicle from being completely burned and causing damage to surrounding vehicles or facilities.
- The gas inflator inside the airbag may expand and explode when exposed to high temperatures, so please be very careful before handling it to avoid personal injury.
- If a fire occurs in the vehicle that does not involve the power battery, a fire extinguisher may be used to extinguish the fire. If the vehicle's power battery area catches fire, use large amounts of continuous firefighting water to cool it down and monitor the temperature of the battery area to prevent re-ignition. Ensure that the battery is no longer heating up before storing the vehicle in an open flat area, and set a safety zone with a radius of about 15m to prevent uninvolved persons from touching the vehicle.
- After taking cooling measures for the power battery on fire, be alert to the risk of the power battery reigniting to avoid danger during transportation.
- After the vehicle fire is extinguished, it is recommended to contact an authorized dealer to handle the situation. Do not touch the vehicle after a fire incident to prevent electric shock, burns, and other accidents.

In order to prevent vehicle fires in a timely and effective manner, pay attention to the following matters during use:

- It is prohibited to store flammable and explosive items inside the vehicle. In the hot summer, if lighters, cleaners, perfume, and other flammable and explosive items are stored in the car, it is very easy to cause a fire or even an explosion.
- Modification of vehicle wiring and addition of electrical parts is prohibited. Adding other electrical appliances (such as high-power stereo systems) will cause the wiring to be overloaded, and the harness can easily heat up, causing a fire.

- It is strictly prohibited to replace a fuse with one that exceeds the rated specifications or with any other metal wire.

It is recommended that the following inspections be performed periodically at an authorized dealer:

- Regularly check for any oil leakage, and promptly clean the grease, oil stains, and other dirt on the motor to prevent grease and oil stains from volatilizing and causing a fire under high-temperature conditions.
- Regularly check whether the wiring, electrical appliances, harness connectors, insulation, and fixing positions of the whole vehicle are normal. If any problems are found, they should be dealt with promptly.

It is recommended to equip your car with a fire extinguisher and know how to use it.

- To ensure driving safety, an onboard fire extinguisher can be equipped, and it should be checked and replaced regularly.

Driving Precautions:

- The vehicle chassis is low and should minimize driving on pothole-ridden roads and bumpy roads to avoid bumping the vehicle chassis and compressing the power battery pack, which may cause the power battery to catch fire due to severe compression.
- Vehicles in the driving process should try to avoid road sections where dry leaves, straw, weeds, and other flammable materials have accumulated, or stop promptly after passing such sections to check whether there are any flammable materials stuck underneath the vehicle.
- When parking, you should try to avoid places exposed to direct sunlight.

## WATER CROSSING EMERGENCY RESPONSE

Before driving through water, you should pay attention to the following matters:

1. Before driving through water, first determine the water depth; the maximum must not exceed the lower edge of the vehicle body.
2. Drive through the waterlogged section at a low speed, and under no circumstances should you stop or reverse in the water.

When driving through water, if the vehicle takes in water, you need to follow the steps below:

1. After pulling your vehicle away from the waterlogged area, park your vehicle in a safe place and check whether water has entered the interior of the vehicle. If so, please remove the water inside the vehicle.
2. If the vehicle can continue to be driven, drive the vehicle to an authorized dealer for a full inspection. If the vehicle cannot continue to be driven, it is recommended that you contact Leapmotor to request assistance.
3. If the vehicle cannot be driven away from the waterlogged area, please perform a power cutoff immediately.
4. Disconnect the negative terminal of the battery when conditions permit.
5. If the vehicle is very severely flooded, all persons inside the vehicle must evacuate to a safe area immediately.

After driving through water, the following checks should be performed immediately when the vehicle is safe:

1. Gently press the brake pedal to dry the brake and check if the brake is functioning properly.
2. Check if the horn is functioning normally.
3. Turn the steering wheel to check whether the electric power assisted steering (EPAS) is working properly.
4. Check whether the external vehicle lamps are working properly.

#### WARNING

- Professional rescuers need to wear appropriate rescue protective equipment when dealing with submerged vehicles, first pull the vehicle out of the water, and then cut the high voltage circuit normally.
- Do not touch flooded vehicles without wearing rescue protective equipment to avoid electric shock incidents.
- After the vehicle has been dragged under or soaked in water, it is recommended to contact an authorized dealer for inspection to avoid personal injury or vehicle damage due to mechanical damage or high voltage safety of the power battery.

#### ATTENTION

- Do not drive on road sections where the depth of standing water is unknown to avoid damaging electrical parts.

- Do not drive on roads with salt-laden water to avoid corrosion of the body.
- Do not drive through water for long periods of time to avoid damage to the vehicle.

## CHARGING EMERGENCY RESPONSE

During charging, when the infotainment screen displays an error message, please unplug the charger, and if necessary, we recommend contacting the authorized dealer as soon as possible for check and repair.

If the vehicle is in the DC fast charging status of the charging station, and there is smoke or odor from the charging port or abnormal phenomena inside the vehicle, please promptly press the emergency stop button on the fast charging pile to stop charging, evacuate the people around the vehicle, and handle the situation according to the relevant procedures at the scene.

If moisture gets near the charging port during charging, please first disconnect the power supply when ensuring safety, then disconnect the plug at the power supply end, then pull out the charger at the car end. Use insulating gloves if necessary, and contact the authorized dealer as soon as possible for check and repair.

Please check the charging cable's cover and casing for any damage before charging. Do not use a charging cable with a damaged cover or casing.

In case of sudden changes in weather during charging (e.g. high wind, rain, snow, thunderstorms, etc.), the charger should be checked in time to see if it is properly connected and dry. Stop charging when necessary.

#### WARNING

- When operating the vehicle, please make sure that you do not carry metal objects (such as necklaces, watches, etc.) on your person to prevent electric shock incidents.

## EMERGENCY TREATMENT FOR POWER BATTERY LEAKAGE

When power battery liquid leakage occurs, it will seriously affect battery safety and even cause fire.

Please do not approach the vehicle where power battery liquid leakage occurs, and it is recommended to contact an authorized dealer immediately to deal with it.

Power battery liquid leakage should be handled by professional rescuers, and they must wear a protective face shield and solvent isolation gloves. Do not touch the liquid directly.

### **WARNING**

- When power battery fluid leaks, avoid skin and eye contact with the fluid. In case of contact, wash with plenty of water and seek medical attention immediately. It is prohibited for any person or animal to ingest any part of the battery or the substances contained in the battery.

### **NOTE**

- Do not dispose of leaked liquid arbitrarily into water, soil, or other environments.

## VEHICLE IDENTIFICATION

### VEHICLE IDENTIFICATION NUMBER (VIN)

The Vehicle Identification Number (VIN) consists of 17 characters and contains information such as the country of manufacture, manufacturer, year, and vehicle feature code.

#### VIN POSITION DISTRIBUTION

Vehicle Identification Number (VIN) is the vehicle's identification code, which is unique and is engraved or affixed at the following locations:

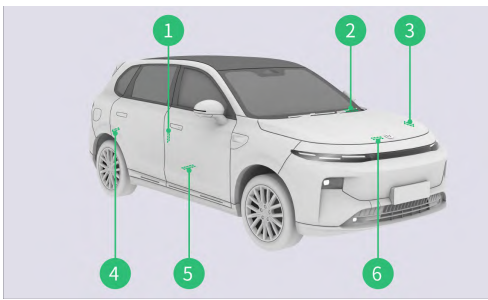

1. Located on the right front door sheet metal (affixed)
2. Located on the sheet metal cross beam on the lower left side of the windshield (affixed)
3. Located in front of the left shock tower (affixed)
4. Located on the upper sheet metal of the right rear wheel housing (affixed)
5. Located on the rear cross beam of the front right seat (engraved)
6. Located on the right side of the bonnet latch (affixed)

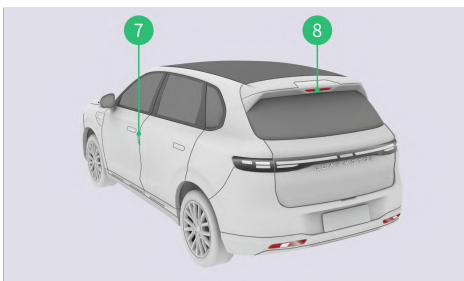

7. Located on the left front door sheet metal (affixed)
8. Located on the inner panel of the liftgate (affixed)

### READ VIN FROM OBD INTERFACE

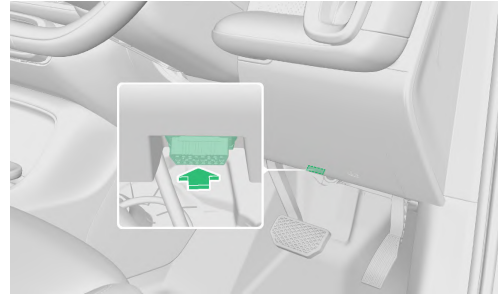

The OBD interface is located on the lower right side of the instrument panel, and data such as VIN and vehicle status information can be read through the dedicated diagnostic tool.

### VEHICLE NAMEPLATE AND IDENTIFICATION

#### VEHICLE NAMEPLATE

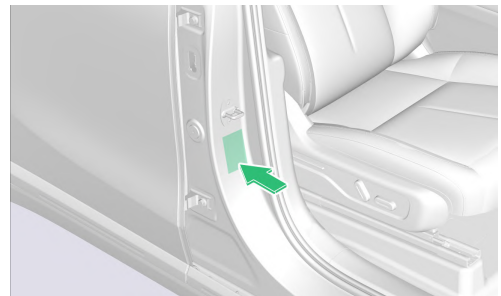

The vehicle nameplate is located on the right side of the vehicle on the outer B-pillar panel. The vehicle nameplate is labeled with the brand, vehicle identification number (VIN), vehicle mass parameters, and other information.

### DRIVE MOTOR NAMEPLATE AND NUMBER LOCATION

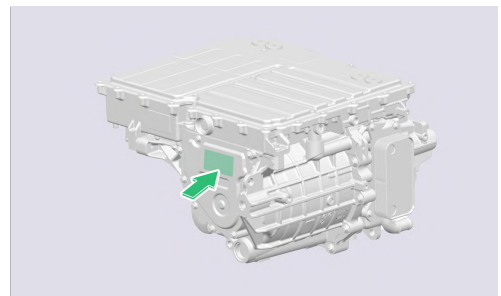

The drive motor nameplate is located on the drive motor shell. The drive motor model and number are located on the drive motor nameplate.



The drive motor model and number label are located on the inner panel of the liftgate.  
**POWER BATTERY NAMEPLATE LOCATION**

**Status 1\***

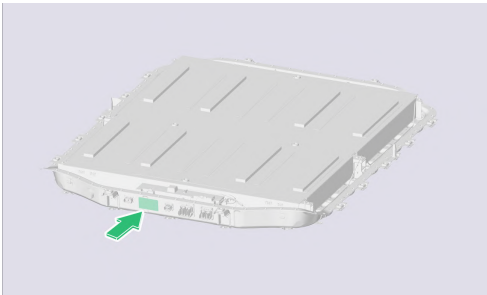

The power battery nameplate is located on the outside of the power battery pack.

**Status 2\***

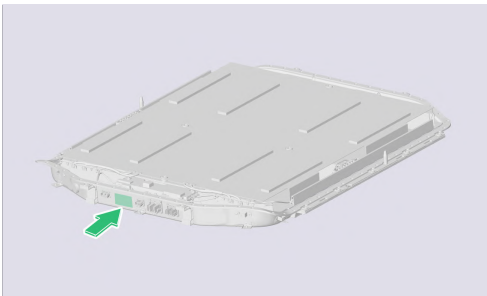

The power battery nameplate is located on the outside of the power battery pack.

**TIRE PRESSURE SIGN**

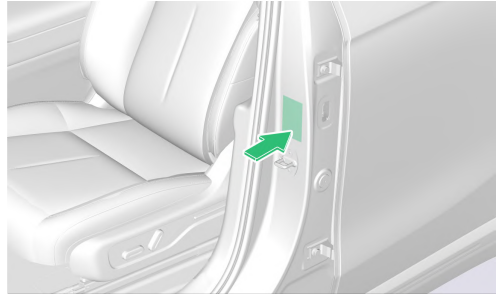

The tire pressure sign is located on the outer panel of the left B-pillar.

**AIR CONDITIONING SYSTEM WARNING SIGN**

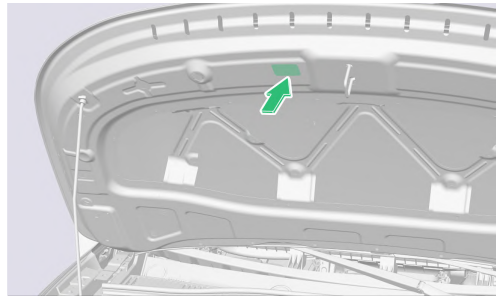

The air conditioning system warning sign is located on the right side of the bonnet latch.

**COOLANT WARNING SIGN**

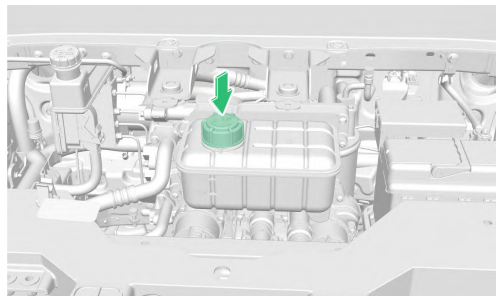

The coolant warning sign is located on the coolant expansion tank cover.

## DRIVE MOTOR HIGH VOLTAGE WARNING SIGN

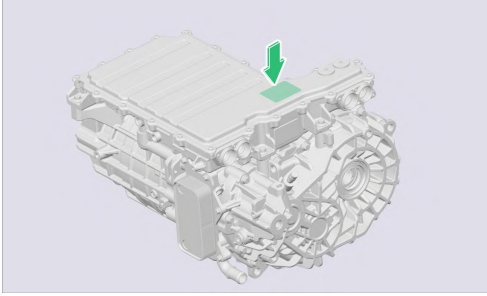

The drive motor high voltage warning sign is located on the drive motor shell.

## POWER BATTERY HIGH VOLTAGE WARNING SIGN

### Status 1\*

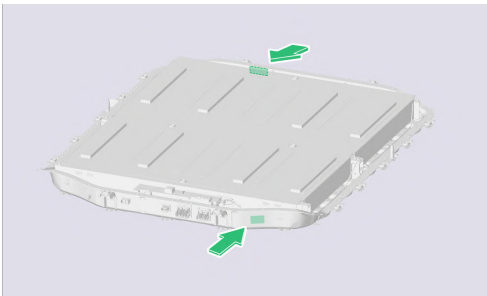

The power battery high voltage warning sign is located on the outside of the power battery pack.

### Status 2\*

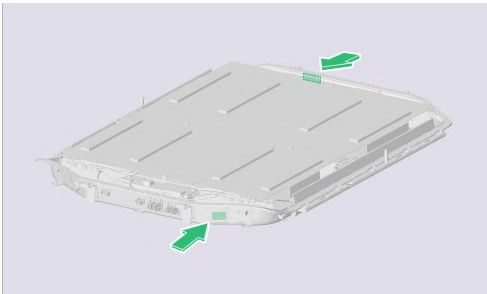

The power battery high voltage warning sign is located on the outside of the power battery pack.

## CHARGING WARNING SIGN

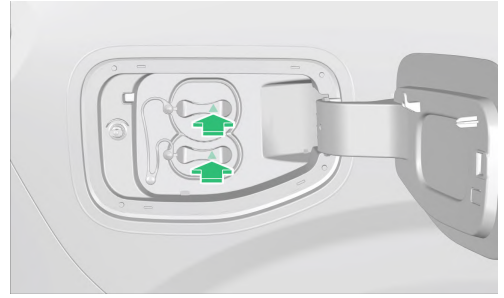

The charging warning sign is located on the AC slow charging port cover and the DC fast charging port cover.

## AIRBAG WARNING SIGN

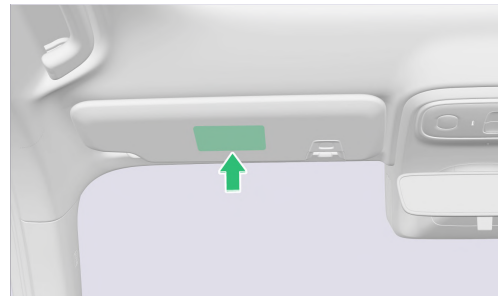

Airbag warning signs are located on the front passenger sun visor, one on the front and one on the back.

## MICROWAVE WINDOW

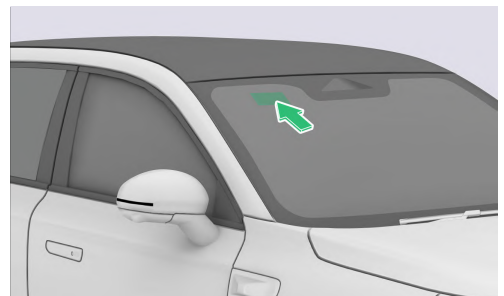

In order to ensure the installation and reading of the vehicle electronic label, the vehicle reserves a microwave window on the right side of the front windshield.

### NOTE

- Do not overlap the glass frame or other objects when affixing the electronic label.

## TECHNICAL PARAMETERS

### VEHICLE BASIC PARAMETERS

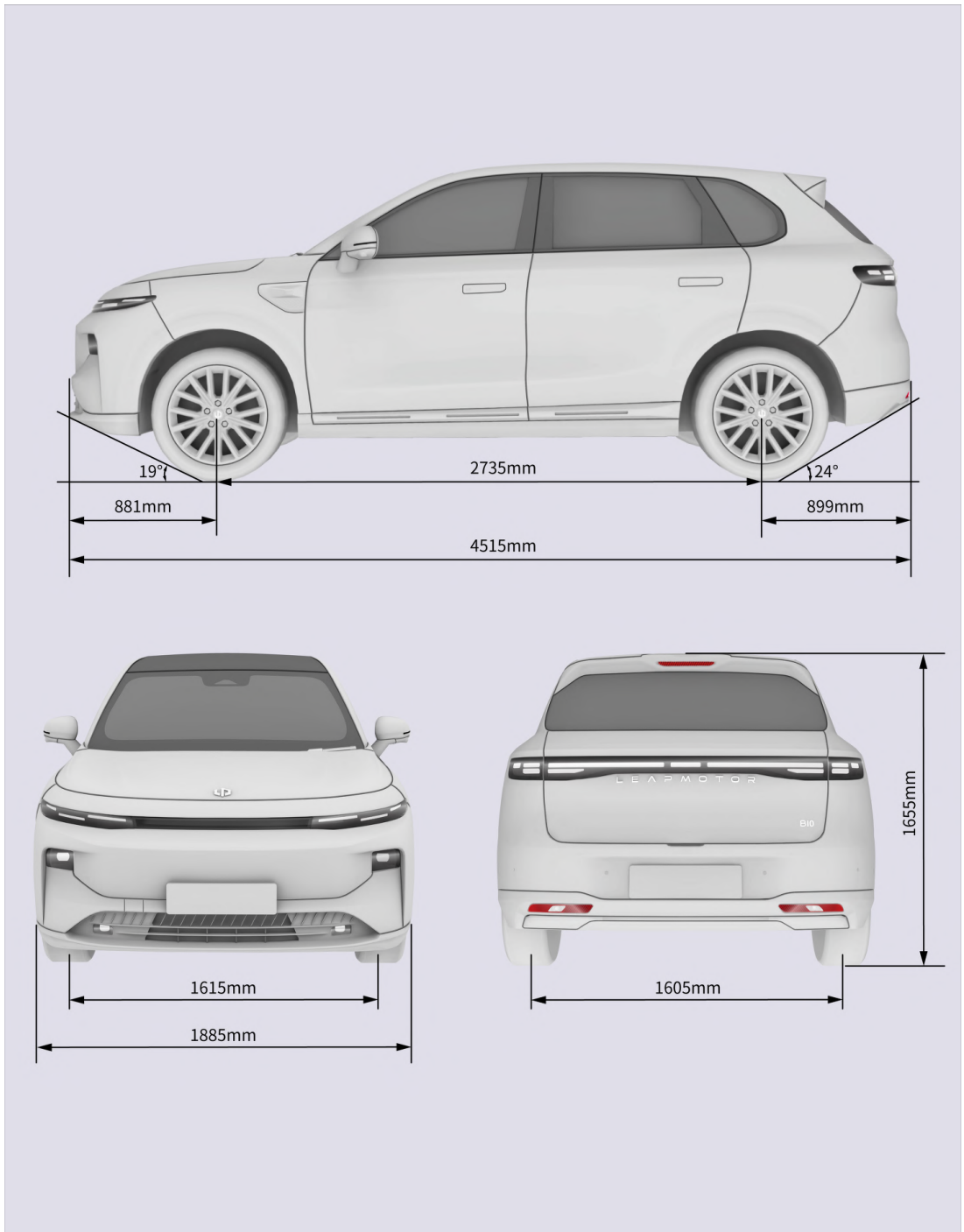

Project		Parameters	
Overall Dimensions (mm)	Length	4515	4515
	Width	1885	1885
	Height	1655	1655
Track width (mm)	Front	1615	1615
	Rear	1605	1605
Wheelbase (mm)		2735	2735
Front suspension/rear suspension (mm)		881/899	881/899
Curb weight (kg)		1780	1845
Axle load (curb weight) (kg)	Front	854	882
	Rear	926	963
Maximum allowable total mass (kg)		2215	2290
Maximum allowable front/rear axle load (kg)	Front	983	1017
	Rear	1265	1308
Minimum ground clearance (mm)		170	170
Minimum turning radius (m)		5.25	5.25
Maximum speed	km/h	170	170
	mile/h	106	106
Maximum gradeability (%)		35	35
Approach angle (°)		19	19
Departure angle (°)		24	24
Number of axes/drive shafts		2/ Second axis	2/ Second axis
Drive Type		4×2 Rear-wheel drive	4×2 Rear-wheel drive
Rated passenger capacity (person)		5	5
NEDC* Driving Range	Km	442	516
	mile	275	321
NEDC* Energy Consumption	kWh/100km	14.0	14.1
	kWh/62mile		
WLTP* Driving Range	Km	361	434
	mile	224	270
WLTP* Energy Consumption	kWh/100km	17.2	17.3

Project		Parameters	
	kWh/62mile		

Note: Exterior rearview mirrors are not included in the vehicle's exterior dimensions.

**POWER BATTERY TECHNICAL PARAMETERS**

Project		Parameters	
Battery cell	Model	L300F139A	CBB91
	Type	LFP	LFP
	Rated Voltage (V)	3.16	3.16
	Rated Capacity (Ah)	139	166
Power battery system	Model	LP-PBP509-AA	LP-PBP508-AA
	Type	LFP	LFP
	Rated Voltage (V)	404.4	404.4
	Rated Capacity (Ah)	139	166
	Total Battery Level (kWh)	56.2	67.1
	Energy Density (Wh/kg)	134.4	142.4
	Number of power battery packs (pc)	1	1
	Power battery pack dimensions (L × W × H) (mm)	1860×1507×133.5	1849×1515×137
	Battery pack weight (kg)	418±12.5	471±14.13
Auxiliary power supply type		Lead-acid battery	Lead-acid battery
Auxiliary power supply voltage (V)		12V	12V
Protection Level		IP67	IP67

## MOTOR TECHNICAL PARAMETERS

Project	Parameters
Motor model	TZ180XY005
Drive motor type	AC permanent magnet synchronous
Drive Type	4×2 Rear-wheel drive
Rated Power (kW)	70
Rated Torque (N · m)	95.5
Peak Power (kW)	160
Peak Speed (r/min)	17000
Peak Torque (N · m)	240

## BRAKE SYSTEM TECHNICAL PARAMETERS

Project	Parameters	
Front wheel brake type	Disc type	
Rear wheel brake type	Disc type	
Parking braking system type	Electronic parking brake	
Brake pedal free stroke (mm)	≤10	
Brake pedal maximum stroke (mm)	140.4	
Normal use range of brake disc	Front brake disc thickness (mm)	23~25
	Rear brake disc thickness (mm)	8~10
Minimum thickness of the brake disc for use	Front brake disc thickness (mm)	23
	Rear brake disc thickness (mm)	8
Normal use range of brake pad	Thickness of front brake pad friction material (mm)	2~8
	Thickness of rear brake pad friction material (mm)	2~7
Minimum thickness of the brake pad	Thickness of front brake pad friction material (mm)	2
	Thickness of rear brake pad friction material (mm)	2

## WHEEL AND TIRE TECHNICAL PARAMETERS

Project		Parameters
Tire specifications	Front wheel	225/50 R18
	Rear wheel	235/50 R18
Tire standard pressure (kPa)	No load (front/rear)	230/230
	Full load (front/rear)	250/250
Wheel balance requirements (g)		60/Unilateral
Residual Unbalance (g)		8/Unilateral
Four-wheel alignment	Front wheel toe	3.5'±6'
	Front wheel camber	-0.283°±0.75°
	Front wheel kingpin castor angle	3.85°±1°
	Front wheel kingpin inclination angle	13.04°±1°
	Rear wheel camber	-0.75°±0.75°
	Rear wheel toe	6.7'±6'

## SEAT TECHNICAL PARAMETERS

Project		Parameters
Driver seat	Seat forward/backward travel distance (a)(mm)	230/30
	The set seat backrest angle (a)(°)	25
	Seat backrest forward/backward adjustable angle (°)	30/70
	Seat upward/downward travel distance (mm)	40/20
Front passenger seat	Seat forward/backward travel distance (a)(mm)	230/30
	The set seat backrest angle (a)(°)	25
	Seat backrest forward/backward adjustable angle (°)	30/70
Rear seat	Rear seat forward/backward movement adjustment distance (mm)	Not adjustable
	Set seat backrest angle (a) (°)	27

Project		Parameters
	Seat backrest forward/backward adjustable angle (°)	Non-adjustable, 40/60 backrest can be put down

Note: When measuring the cushion depth.

## OTHER MAIN ASSEMBLY TECHNICAL PARAMETERS

Project		Parameters
Reducer	Type	Central Reducer
Suspension	Front	MacPherson type independent suspension
	Rear	Multi-link independent suspension
Steering gear	Type	Pinion-and-rack
Steering column	Type	Electric power steering

## TYPE AND DOSAGE OF VEHICLE FILLING FLUID

Project	Specifications	Dosage
Coolant	OAT-40°C	9 ± 0.45L
Brake fluid	DOT4	660 ± 50mL
A/C refrigerant	See air conditioning system warning sign	See air conditioning system warning sign
Reducer gear oil	Idemitsu lubricant LI-004C	1.75 ± 0.05L
Windshield washing fluid	Ethanol washing fluid freezing point -30°C	1 ± 0.2L

Note:

- Please choose coolant and windshield washing fluid with an appropriate freezing point according to the actual temperature of the vehicle environment to avoid damage to the vehicle.
- The above fluid dosages are design values; the actual dosages may vary slightly due to changes in products, equipment, and climate, etc. Please refer to the actual vehicle.
- For detailed vehicle information and fluid parameters, please consult the authorized dealer.

## LIGHT BULB PARAMETERS

Functions	Type	Power (W)	Color
Low beam	LED	22	White
High beam	LED	37	White
Front turn signal lamp	LED	23	Amber
Front position lamp	LED	3	White
Rear turn signal lamp	LED	5	Amber
Daytime running lamp	LED	22	White
Rear position lamp (side)	LED	8	Red
Rear position lamp (center)*	LED	4.5	Red
Stop lamp	LED	3	Red
rear reversing lamp	LED	3.6	White
High-mounted stop lamp	LED	2.6	Red
Front fog lamp	LED	6.2	White
Rear fog lamp	LED	2	Red
License plate lamp	LED	0.4	White
Ambient light (side vent)*	LED	1.25	/
Ambient light (center vent)*	LED	2.43	/
Reading light	LED	2	White
Trunk Illuminating Light	LED	0.36	White

## RADIO TECHNOLOGY INFORMATION

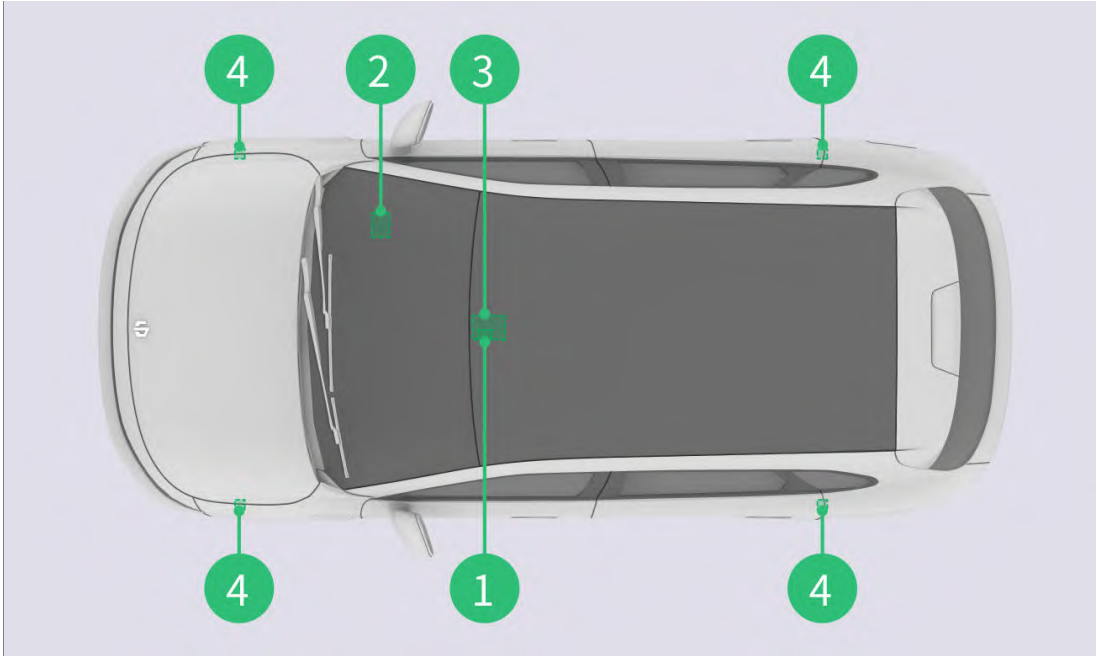

Band (MHz)	Maximum output power (W) (peak RMS)	Device	Radio Position	Country	Identification
GSM900: 880-915	2	IoV host	2	—	—
GSM1800: 1710-1785	2	IoV host	2	—	—
WCDMAB1: 1920-1980	0.25	IoV host	2	—	—
WCDMAB5: 824-849	0.25	IoV host	2	—	—
WCDMAB8: 880-915	0.25	IoV host	2	—	—
LTEB1: 1920-1980	0.2	IoV host	2	—	—
LTEB3: 1710-1785	0.2	IoV host	2	—	—
LTEB5: 824-849	0.2	IoV host	2	—	—
LTEB7: 2500-2570	0.2	IoV host	2	—	—

Band (MHz)	Maximum output power (W) (peak RMS)	Device	Radio Position	Country	Identification
LTEB8: 880-915	0.2	IoV host	2	—	—
LTEB20: 832-862	0.2	IoV host	2	—	—
LTEB28: 703-748	0.2	IoV host	2	—	—
LTEB38: 2570-2620	0.2	IoV host	2	—	—
LTEB40: 2300-2400	0.2	IoV host	2	—	—
BLE: 2400-2483.5	0.002	IoV host	2	—	—
GNSS: 1560-1605	(receive only)	IoV host	2	—	—
BT: 2400-2483.5	0.001	Smart cockpit host	3	—	—
WIFI: 2400-2483.5	0.1	Smart cockpit host	3	—	—
WIFI: 5150-5250	0.016				
WIFI: 5745-5825					
1-30	16.5	Wireless charging module for mobile phones	1	—	—
433.92	< 0.005	Tire pressure sensor	4	Australia	

**NOTE**

- Radio certification information is affixed on the surface of the part; refer to the corresponding part label for detailed information.

## SVHC INFORMATION TRANSMISSION

<b>Communication of information according to Article 33 REACH</b>	
Leapmotor B10 Model (2025)	
<p>This product is composed of articles defined under Article 3(3) of the Regulation No. 1907/2006 of the European Parliament and the Council concerning the Registration, Evaluation, Authorisation and Restriction of Chemicals (REACH). Any supplier shall comply with the duty to communicate information on substances in articles in accordance with Article 33. This product, including any article that the product is composed of, does contain substances meeting the criteria in Article 57 and identified in accordance with Article 59(1) in a concentration above 0.1% weight by weight (w/w). We inform that lead (CAS-No. 7439-92-1) is used in almost all product categories, primarily as an alloying element and also exists in batteries. Recycled aluminum and metals may contain lead as an impurity.</p>	
<b>Location of article containing the substance in the product (Detailed, including optional equipment)</b>	<b>Name of substance meeting the criteria in Article 57 and identified in accordance with Article 59(1) in a concentration above 0.1% weight by weight (Typical use according to the REACH Annex XV Dossier)</b>
EXTERNAL POWER AMPLIFIER	2-methyl-1-(4-methylthiophenyl)-2-morpholinopropan-1-one
EXTERNAL POWER AMPLIFIER	Lead
ELECTRIC SUNSHADE CURTAIN ASSEMBLY	Lead
ELECTRIC SUNSHADE CURTAIN ASSEMBLY	Lead
ELECTRIC SUNSHADE CURTAIN ASSEMBLY	Lead monoxide (lead oxide)
ELECTRIC SUNSHADE CURTAIN ASSEMBLY	Diboron trioxide
DRIVER MONITORING SYSTEM CAMERA ASSEMBLY	Lead
DRIVER MONITORING SYSTEM CAMERA ASSEMBLY	1,3,5-Tris(oxiran-2-ylmethyl)-1,3,5-triazinane-2,4,6-trione (TGIC)
DRIVER MONITORING SYSTEM CAMERA ASSEMBLY	Diboron trioxide
DRIVER MONITORING SYSTEM CAMERA ASSEMBLY	2-methyl-1-(4-methylthiophenyl)-2-morpholinopropan-1-one
DRIVER MONITORING SYSTEM CAMERA ASSEMBLY	Melamine
TIRE REPAIR AIR PUMP AND ITS ACCESSORIES	Lead
REVERSING RADAR PROBE	Orange lead (lead tetroxide)
STEEL WHEEL ASSEMBLY	1,3,5-Tris(oxiran-2-ylmethyl)-1,3,5-triazinane-2,4,6-trione (TGIC)
REAR POSITION LAMP	Lead
REAR POSITION LAMP	Lead monoxide (lead oxide)

REAR MOTOR INLET HOSE	Diazene-1,2-dicarboxamide (C,C'-azodi(formamide)) (ADCA)
REAR MOTOR INLET HOSE	Formamide
BACK ASSY RR LH	Lead
AC CHARGING PLUG	Triphenyl phosphate
AC CHARGING PLUG	4,4'-isopropylidenediphenol
SEALING PRESSURE PLATE	Bis(α,α-dimethylbenzyl) peroxide
INSTRUMENTATION CONTROL UNIT DISPLAY	1-Methyl-2-pyrrolidone (NMP)
TRIM INNER ASSY DOOR REAR RIGHT HAND	Bumetrizole (UV-326)
TRIM INNER ASSY DOOR REAR RIGHT HAND	Diazene-1,2-dicarboxamide (C,C'-azodi(formamide)) (ADCA)
BRAKE ASSY RR RH	Bis(α,α-dimethylbenzyl) peroxide
BRAKE ASSY RR RH	Lead
BRAKE ASSY RR RH	O,O,O-triphenylthiophosphate ester
GUARD PLATE LAMP RR RH	Bumetrizole (UV-326)
GUARD PLATE LAMP RR RH	diphenyl(2,4,6-trimethylbenzoyl)phosphine oxide
GUARD PLATE LAMP RR RH	Lead
GUARD PLATE LAMP RR RH	Lead monoxide (lead oxide)
GUARD PLATE LAMP RR RH	1-Methyl-2-pyrrolidone (NMP)
GUARD PLATE LAMP RR RH	Trisiloxanes
TRIM ASSY DR FRT RH	Bumetrizole (UV-326)
TRIM ASSY DR FRT RH	Diazene-1,2-dicarboxamide (C,C'-azodi(formamide)) (ADCA)
LEFT FRONT POSITION TURNING DAYTIME RUNNING LIGHT ASSEMBLY	Melamine
LEFT FRONT POSITION TURNING DAYTIME RUNNING LIGHT ASSEMBLY	1,3,5-Tris(oxiran-2-ylmethyl)-1,3,5-triazinane-2,4,6-trione (TGIC)
LEFT FRONT POSITION TURNING DAYTIME RUNNING LIGHT ASSEMBLY	Cyclohexane-1,2-dicarboxylic anhydride
LEFT FRONT POSITION TURNING DAYTIME RUNNING LIGHT ASSEMBLY	Lead
LEFT FRONT POSITION TURNING DAYTIME RUNNING LIGHT ASSEMBLY	2-(2H-benzotriazol-2-yl)-4-(1,1,3,3-tetramethylbutyl)phenol (UV-329)
LEFT FRONT POSITION TURNING DAYTIME RUNNING LIGHT ASSEMBLY	1,3,5-Tris(oxiran-2-ylmethyl)-1,3,5-triazinane-2,4,6-trione (TGIC)

LEFT FRONT POSITION TURNING DAYTIME RUNNING LIGHT ASSEMBLY	Cyclohexane-1,2-dicarboxylic anhydride
LEFT FRONT POSITION TURNING DAYTIME RUNNING LIGHT ASSEMBLY	Lead
BRAKE ASSY RH FRT	Lead
BRAKE ASSY RH FRT	Bis( $\alpha,\alpha$ -dimethylbenzyl) peroxide
HEADLAMP FRT RH	diphenyl(2,4,6-trimethylbenzoyl)phosphine oxide
HEADLAMP FRT RH	Lead
HEADLAMP FRT RH	1-Methyl-2-pyrrolidone (NMP)
HEADLAMP FRT RH	Diboron trioxide
SEAT ASSY FR RH	Lead
SEAT ASSY FR RH	Melamine
SEAT ASSY FR RH	2,2',6,6'-tetrabromo-4,4'-isopropylidenediphenol
INTELLIGENT INTEGRATED BRAKING SYSTEM ASSY	Lead
INTELLIGENT INTEGRATED BRAKING SYSTEM ASSY	Lead monoxide (lead oxide)
INTELLIGENT INTEGRATED BRAKING SYSTEM ASSY	Diboron trioxide
INTELLIGENT INTEGRATED BRAKING SYSTEM ASSY	Cobalt(II) dinitrate
INTELLIGENT INTEGRATED BRAKING SYSTEM ASSY	Bis( $\alpha,\alpha$ -dimethylbenzyl) peroxide
INTELLIGENT INTEGRATED BRAKING SYSTEM ASSY	Diazene-1,2-dicarboxamide (C,C'-azodi(formamide)) (ADCA)
MIDDLE CONTROL DISPLAY	1,3,5-Tris(oxiran-2-ylmethyl)-1,3,5-triazinane-2,4,6- trione (TGIC)
MIDDLE CONTROL DISPLAY	Cyclohexane-1,2-dicarboxylic anhydride
MIDDLE CONTROL DISPLAY	Diboron trioxide
MIDDLE CONTROL DISPLAY	Lead
TRIM RING ASSY	diphenyl(2,4,6-trimethylbenzoyl)phosphine oxide
RADIAL TIRE	1, 3-hydroquinone
TRIM ASSY INR DR RR LH	Bumetizole (UV-326)
TRIM ASSY INR DR RR LH	Diazene-1,2-dicarboxamide (C,C'-azodi(formamide)) (ADCA)
BRAKE ASSY RR LH	Bis( $\alpha,\alpha$ -dimethylbenzyl) peroxide
BRAKE ASSY RR LH	Lead
BRAKE ASSY RR LH	O,O,O-triphenylthiophosphate ester

GUARD PLATE LAMP RR LH	Bumetrizole (UV-326)
GUARD PLATE LAMP RR LH	diphenyl(2,4,6-trimethylbenzoyl)phosphine oxide
GUARD PLATE LAMP RR LH	Lead
GUARD PLATE LAMP RR LH	Lead monoxide (lead oxide)
GUARD PLATE LAMP RR LH	1-Methyl-2-pyrrolidone (NMP)
GUARD PLATE LAMP RR LH	Trisiloxanes
TRIM ASSY DR FRT LH	Bumetrizole (UV-326)
TRIM ASSY DR FRT LH	Diazene-1,2-dicarboxamide (C,C'-azodi(formamide)) (ADCA)
LEFT FRONT POSITION TURNING DAYTIME RUNNING LIGHT ASSEMBLY	1,3,5-Tris(oxiran-2-ylmethyl)-1,3,5-triazinane-2,4,6-trione (TGIC)
LEFT FRONT POSITION TURNING DAYTIME RUNNING LIGHT ASSEMBLY	Cyclohexane-1,2-dicarboxylic anhydride
LEFT FRONT POSITION TURNING DAYTIME RUNNING LIGHT ASSEMBLY	Lead
LEFT FRONT POSITION TURNING DAYTIME RUNNING LIGHT ASSEMBLY	Melamine
LEFT FRONT POSITION TURNING DAYTIME RUNNING LIGHT ASSEMBLY	2-(2H-benzotriazol-2-yl)-4-(1,1,3,3-tetramethylbutyl)phenol (UV-329)
LEFT FRONT POSITION TURNING DAYTIME RUNNING LIGHT ASSEMBLY	1,3,5-Tris(oxiran-2-ylmethyl)-1,3,5-triazinane-2,4,6-trione (TGIC)
LEFT FRONT POSITION TURNING DAYTIME RUNNING LIGHT ASSEMBLY	Cyclohexane-1,2-dicarboxylic anhydride
LEFT FRONT POSITION TURNING DAYTIME RUNNING LIGHT ASSEMBLY	Lead
BRAKE ASSY LH FRT	Lead
BRAKE ASSY LH FRT	Bis(α,α-dimethylbenzyl) peroxide
HEADLAMP FRT LH	diphenyl(2,4,6-trimethylbenzoyl)phosphine oxide
HEADLAMP FRT LH	Lead
HEADLAMP FRT LH	1-Methyl-2-pyrrolidone (NMP)
HEADLAMP FRT LH	Diboron trioxide
SEAT ASSY FR LH	Lead
SEAT ASSY FR LH	2,2',6,6'-tetrabromo-4,4'-isopropylidenediphenol
SEAT ASSY FR LH	Melamine

The information provided in this document related to material and substance content represents our knowledge and belief, which may be based in whole or in part on available information provided by suppliers to us.



**LEAPMOTOR**

<https://www.leapmotor.net/au>

Copyright by LEAPMOTOR.

The information contained in this publication is effective as of the date indicated below. LEAPMOTOR reserves the right to make changes to the technical specifications, features and design of the vehicles relative to the information in this publication as well as changes to the publication itself.

Edition: Nov 2025, LEAPMOTOR.