

T03

USER MANUAL



Preface

About the Manual

Instructions to users.....9
Prompt information..... 9
Graphic information..... 10
Get the electronic copy of the manual..... 11
Description of vehicle power supply states..... 11

Introduction to Leapmotor Assistant

Exterior.....14
Interior..... 14

Charging

Charging instructions..... 18
Charging precautions..... 18
AC charger..... 19
Charging port..... 20
Charging method.....21
Timed charging..... 23

Travel Preparations

Trip planning.....26
Pre-driving inspection..... 26

Vehicle Unlocking

Keys..... 28
Key fob.....28
Mechanical key..... 30
Bluetooth key..... 31

Vehicle locating..... 31
Vehicle locating with key fob.....31
Unlocking from outside.....32
Unlocking with key fob.....32

Entering the vehicle

Open the door.....34
Exterior door handle..... 34
Welcome lighting..... 34
Front row lighting.....34

Identity authentication

Operation password..... 36
Set operation password.....36
Modify operation password..... 36
Binding the vehicle on Leapmotor App..... 37
Owner binding authentication..... 37
Unbinding..... 38

Loading the vehicle

Open rear trunk..... 40
Open rear trunk..... 40
Folding of rear seat back..... 41
Easy loading..... 42
Rear trunk lamp.....42
Item loading.....42
Close rear trunk..... 43
Close rear trunk.....43

Contents

Riding

Seat belt.....	46	Window control.....	64
Protective effect of seat belts.....	46	Locking from inside.....	67
Correct sitting posture.....	47	Steering wheel control.....	67
Proper use of seat belts.....	48	Steering wheel adjustment.....	69
Seat belt pretensioners*.....	49	Riding on front passenger's side.....	70
Seat belt reminder warning lamp.....	49	Front passenger's seat adjustment.....	70
How do pregnant women use seat belts.....	50	Window control.....	72
Seat belt system inspection.....	50	Riding in rear seats.....	72
Replacement of seat belt system components.....	50	Rear seat headrest adjustment.....	72
Airbag.....	50	Window control.....	73
Protective effect of air bags.....	50	Rear storage.....	73
Location of airbags.....	51	Comfortable riding.....	74
Deployment of airbags.....	52	A/C.....	74
Airbag fault warning lamp.....	53	Sunroof shade control*.....	77
Replacement of airbag system components.....	53	Front storage.....	78
Vehicle disposal.....	54	Assist grip.....	81
Child safety.....	54	Sun visor.....	81
Instructions for children riding.....	54	Vanity mirror.....	82
Child safety lock.....	55	Onboard power supply.....	83
Installation of child safety seats.....	55	USB port.....	83
Selection of child restraint system.....	58	IVI system.....	84
Riding on driver's side.....	60	IVI system.....	84
Driver seat adjustment.....	60	Vehicle Control.....	85
Exterior rearview mirror adjustment.....	62	System Settings.....	87
Interior rearview mirror adjustment.....	62	Navigation.....	88
		Media.....	88

DAB Radio.....89
 Tel..... 90
 Speech recognition*..... 90

Driving

View the instrument cluster..... 92
 Instrument cluster views..... 92
 Left information display..... 92
 Middle information display..... 93
 Speedometer..... 93
 Power meter..... 94
 Right information display..... 94
 Battery meter and range..... 95
 Feedback information display..... 95
 Instrument cluster indicator lamps and warning lamps..... 96
 Tire Pressure Monitoring System..... 100
 Drive out of parking space..... 102
 Start the vehicle..... 102
 Driving mode switching..... 102
 Energy recovery..... 103
 Gear..... 103
 Speed control..... 104
 Pedals..... 104
 Brake assist system..... 105
 Pedestrian Warning System..... 109
 AutoHold..... 110
 Intelligent driving..... 111

Cruise control system (CCS)..... 111
 Adaptive cruise control (ACC)..... 112
 Forward Collision Warning (FCW)..... 118
 Autonomous Emergency Braking (AEB)..... 122
 Lane Departure Warning (LDW)..... 124
 Lane Keeping Assist (LKA)..... 127
 Blind Spot Detection (BSD)..... 131
 Door Open Warning (DOW)..... 133
 Intelligent Speed Assist (ISA)*..... 134
 Driver Drowsiness and Attention Warning (DDAW)*..... 137
 Advanced Driver Distraction Warning (ADDW)*..... 138
 Driving at night..... 140
 Lamp switch..... 140
 Driving in special weather conditions..... 144
 Driving in foggy days..... 144
 Driving in rainy days..... 144
 Driving in hot seasons..... 146
 Driving in cold seasons..... 147
 Event data recorder..... 148

Parking

Parking settings..... 152
 Reversing assist system..... 152
 Electronic parking brake (EPB)..... 154

Leave the vehicle

Preparations..... 158
 Closing windows..... 158

Contents

Powering off.....	158
Unlock in vehicle.....	158
Central control unlocking.....	158
Interior handle unlocking.....	159
After leaving the vehicle.....	159
Safety tips for leaving the vehicle.....	159

Locking

Locking the vehicle.....	162
Locking with key fob.....	162
Exterior rearview mirror folding.....	162
Exterior rearview mirror folding.....	162

Walking away

Walking away.....	164
Guide Me Home.....	164

Maintenance and Cleaning

Vehicle cleaning.....	166
Exterior cleaning.....	166
Interior cleaning.....	167
Vehicle maintenance.....	169
Exterior maintenance.....	169
Interior maintenance.....	170
Tire maintenance.....	170
Wiper.....	172
Bulbs.....	173
Brake wear.....	174
Corrosion protection measures.....	174

Long-term storage of vehicle.....	175
Adding fluids.....	175
Front compartment.....	175
Checking/adding coolant.....	177
Checking/adding brake fluid.....	178
Add windshield washing fluid.....	179
Wiper.....	172
Bulbs.....	173
Replacing fuses.....	182
Fuse description.....	182
Front trunk fuse box.....	183
Auxiliary fuse box in front compartment.....	185
Battery positive fuse box.....	186
Instrument panel fuse box.....	187
Battery maintenance.....	189
traction battery.....	189
Traction battery recycling.....	191
LV battery.....	192

Regular maintenance

Regular maintenance.....	196
Maintenance importance.....	196
Precautions for routine maintenance.....	196
Maintenance content.....	196
Table of Maintenance Intervals.....	201

Emergency treatment

Owner emergencies.....	208
------------------------	-----

Urgent unlocking/locking..... 208
 Initialization of sunroof shade *..... 210
 Turning on hazard warning lamps..... 211
 Wearing the reflective vest..... 212
 Knowing attached tools..... 212
 Setting up the warning triangle..... 213
 Emergency treatment of tires..... 213
 Jump starting..... 217
 Replacing the remote control key battery..... 218
 Charging emergency plan..... 219
 Emergency vehicle starting..... 220
 E-CALL*..... 220
 Road rescue..... 222
 Getting the vehicle out of the trap..... 222
 Vehicle towing..... 222
 Incident rescue..... 224
 Rescue of vehicle fire..... 224
 Vehicle wading rescue..... 225

Traction battery leakage rescue..... 226

Technical information

Vehicle information..... 228
 Vehicle identification number (VIN)..... 228
 Vehicle nameplates and labels..... 230
 Technical parameters..... 236
 Overall dimensions of vehicle..... 236
 Technical parameters of vehicle..... 236
 Technical parameters of traction battery..... 237
 Technical parameters of motor..... 237
 Technical parameters of motor controller..... 238
 Technical parameters of other main assemblies..... 238
 Technical parameters of brake system..... 238
 Technical parameters of wheels and tires..... 239
 Type and usage of fluids to be added for the vehicle..... 240
 Bulb parameters..... 240
 SVHC information transmission..... 241
 Radio technical information..... 245

PREFACE



Dear user:

Thank you for choosing the Leapmotor intelligent new energy vehicle with excellent safety, comfort, power and economy. We look forward to bringing more fun to your work and life with high-quality products and services.

Please read this manual carefully before using the vehicle, and keep it accessible for future use. This manual will help you better understand and use Leapmotor vehicles, so that your vehicle can keep its best performance in future use. In-depth knowledge of the vehicle will help you have a clearer understanding of the safety and fun of the vehicle.

If you have any problems and needs in the process of use, please contact the authorized dealer nearby. We will provide you with the best service in maintenance and repair. Please be sure to complete the maintenance work on time in accordance with the maintenance specification of the main equipment manufacturer.

The illustrations used in this manual are mainly used to show some features or functions of the vehicle, and are for reference only. Due to different model configurations and later upgrades, the instructions in this manual may be different from the actual configurations of the vehicle you purchase, therefore, the actual vehicle you receive shall prevail. Leapmotor reserves the right to change, supplement or terminate the contents of this manual without further notice.

This manual is an integral part of the vehicle. When selling or lending this vehicle, please hand over this manual to the new owner.

Thank you for your support and love for Leapmotor. Have a nice ride!

October 2024

No content of this manual may be reprinted or reproduced without the written permission of Leapmotor.

Violators will be prosecuted

ABOUT THE MANUAL



INSTRUCTIONS TO USERS

VEHICLE CONFIGURATION

This manual contains all the standard and special configurations available to the T03 model series at this stage. Therefore, some of the configurations or functions described in this manual may not be available on your vehicle. For specific configuration information, please consult the relevant documents or consult the corresponding authorized dealer.

HARDWARE AND SOFTWARE MODIFICATION

The equipment or after sales accessories that are not modified, installed, dismantled and repaired by the authorized dealer may damage the vehicle and threaten personal safety, and illegal modification of the vehicle is prohibited.

- Do not modify the chassis system of the vehicle, which may affect vehicle control safety and threaten personal safety.
- Do not modify the electronic components of the vehicle (circuits, lights and controllers, etc.). It is strictly prohibited to flash or root without authorization, which may cause system failure and threaten personal safety.
- Do not modify the seats, steering wheel, seat belts and airbag system, which may affect safety and threaten personal safety.
- Do not modify the relevant charging equipment, in order to avoid charging fault and causing fire.

It is suggested to use the genuine parts or approved parts of Leapmotor. The parts of Leapmotor are strictly tested to ensure its comfort, safety and reliability.

If there is a need for modification and retrofitting of the vehicle, please contact Leapmotor. Other problems such as vehicle damage and performance degradation caused by other modification actions are not covered by the quality warranty.

VEHICLE SCRAPPING

The airbag and seat belt pre-tensioner of the vehicle contain explosive chemicals. If the vehicle is scrapped without removing the airbag and seat belt pre-tensioner, it may cause accidents. Please dismantle or scrap the vehicle in accordance with local regulations.

VEHICLE RECALL

In case of vehicle recall, Leapmotor will provide a reasonable solution in accordance with the defects of the vehicle. If the problem can be solved by repairing or replacing parts, in order to eliminate the vehicle defects and ensure your driving safety as soon as possible, you should, after receiving the recall notice of Leapmotor or obtaining relevant information through official channels, actively cooperate with the authorized dealer to carry out recall maintenance service.

PROMPT INFORMATION

This manual is prepared in accordance with the rules of the vehicle use scenarios so that you can quickly find and use the relevant information.

About the Manual

The contents of this manual are divided into well-organized chapters, catalogue listed by chapter and Acquaintance of Leapmotor Assistant (pictures) can help you find the information you need quickly.

Some of the chapters or functions of this manual may not apply to all models, and the different configurations are marked with "*".

In this manual, you will see warnings about personal safety or possible damages to the vehicle. When operating the vehicle, you must follow the warnings to avoid personal injuries or damages to the vehicle.

Except for special instructions, the instructions on the vehicle orientation (front, rear, left and right) in this manual are based on the forward direction of the vehicle.

The type, layout and usage of warnings in this manual are as follows:

WARNING

- Personal injury.
- It is used to warn you of medium and high hazards.

ATTENTION

- Vehicle damage risk.
- It is used to remind you of minor hazards, and ignoring this information may cause damages to the vehicle.

NOTE

- Helpful supporting information.

- It is used to prompt the supporting information that may be helpful to you.

ECO

- Environmental protection instructions.

GRAPHIC INFORMATION

ARROWS IN THE ILLUSTRATIONS

Indicating the key parts, operation action and action direction (such as pushing up, pulling down, turning left, moving right, shaking back and forth, etc.).

SAFETY SIGN IN THE ILLUSTRATIONS



This safety sign means "strictly prohibited", "this is strictly prohibited" or "this situation is strictly prohibited".

GET THE ELECTRONIC COPY OF THE MANUAL

You can view the electronic user manual by touching the User Manual app on the Infotainment Screen.

DESCRIPTION OF VEHICLE POWER SUPPLY STATES

There are three states of vehicle power supply.

Vehicle "Unlocked" state: ON1 state. The vehicle is unlocked, and the door is not opened.

Vehicle "Power-on" state: ON2 state. Unlock the vehicle, open the door and enter the vehicle, and the vehicle is not in the "READY" state.

Vehicle "Ready" state: ON3 state. Unlock the vehicle, open the door and enter the vehicle, press the start/stop button while stepping on the brake pedal, and the instrument cluster displays the "READY" state.

NOTE

- For models equipped with the handheld alcoguard device, the driver must undergo a breath test before starting the vehicle.

INTRODUCTION TO LEAPMOTOR ASSISTANT



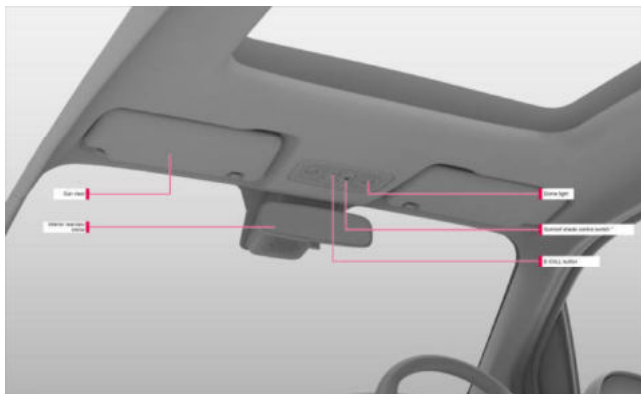

CHARGING



CHARGING INSTRUCTIONS

CHARGING PRECAUTIONS

Please pay attention to the following during charging:

- When the low traction battery warning indicator in the instrument cluster goes on, please charge the vehicle as soon as possible. Do not charge the vehicle after the power is completely exhausted, otherwise it will affect the service life of the traction battery system.
- Before charging, please make sure that the vehicle is in "P" gear, and the parking braking system is turned on.
- If the traction battery needs to be heated or cooled, the battery will be automatically heated or cooled after the charger is inserted until the battery reaches the appropriate temperature, so the power in the charging phase will fluctuate, and the time required for the battery to be fully charged may be prolonged.
- When the battery temperature is low, the vehicle may not be charged at full power at the beginning of charging, and the charging power will increase as the battery temperature increases. During charging, choose warmer places such as the basement as far as possible, which can shorten the charging time. When the conditions are met, the warm-up system will be turned on to heat the battery.
- In order to avoid damages to the charging equipment, it is prohibited to close the charging port plate when the charging port plate is opened. Do not hit the charging device or put it near the heater or other heat sources. Do not pull or twist the charging cable.
- When the external power grid supplies power again after a short power cutoff, the charging equipment will automatically restart charging (the charging restart time may be prolonged), and there is no need to reconnect the charging equipment. In case of multiple power cutoffs, please stop charging and check whether the power supply is normal.
- During vehicle charging, if the power grid fluctuates greatly, the charging power will fluctuate, and the charging may even be suspended.
- When the traction battery is fully charged, the system will automatically stop charging.
- Do not charge the vehicle by fast charging and slow charging at the same time, so as not to damage the vehicle.
- If the vehicle is not used for a long time, users are advised to carry out AC charging (to 100%) at least once a month and fully charge the battery for battery balancing and maintenance to improve the service life of the vehicle battery. Do not leave the vehicle used for more than 7 days when the traction battery is too low (about 10%-20%).
- It is recommended to fully charge the battery by AC slow charging in the first three charges after delivery of the vehicle, which is helpful to maintain the state of health of the battery.
- In order to avoid the impact of high-charge floating charging on the battery health, if you need to recharge the vehicle when it is at a very high charge (more than 97%), you need to consume part of the power before you can charge the vehicle normally.
- When the vehicle is being charged, the radiator fan may be turned on automatically, which is a normal phenomenon.
- In case of charging with the A/C system turned on, the charging time will be prolonged.

AC CHARGER

STATUS 1*

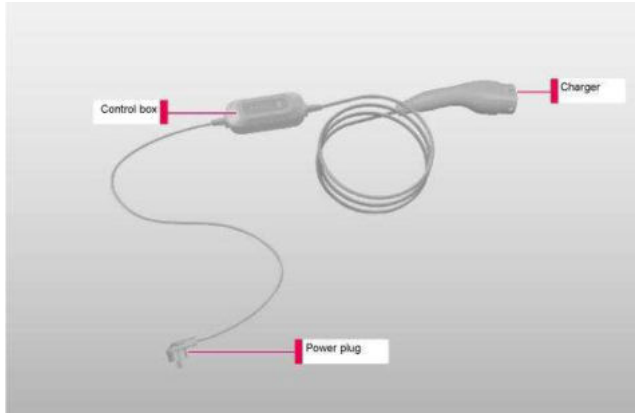

STATUS 2*

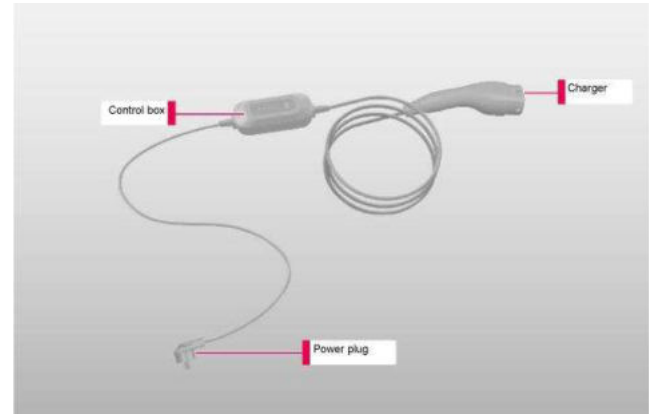

ⓘ NOTE

- For the specific definitions of the charging gun control box indicators, please refer to the charging control box label.

Charging

STATE III*

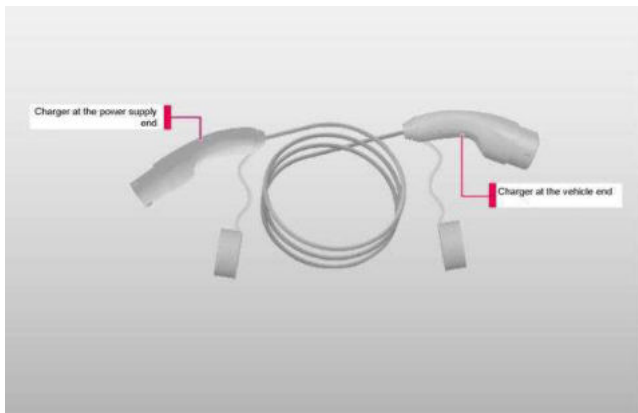

⚠ WARNING

- Do not use the charging connection equipment in the sun or in a closed environment.
- Do not modify the AC charging connection equipment without authorization, otherwise it may cause hazards.
- Do not step on the charging cable, pull the cable, bend or tie the cable.
- Charging is prohibited when the charging cable is damaged.
- When the charging equipment is faulty, do not try to solve it by yourself, and it is recommended to contact the authorized dealer.
- Please use a reliably grounded socket.
- Please use a power supply with leakage protection.
- Make sure that the power plug and power supply socket are matched before charging.

🕒 NOTE

- When the charger is not in use, cover it with the protection cover.

CHARGING PORT

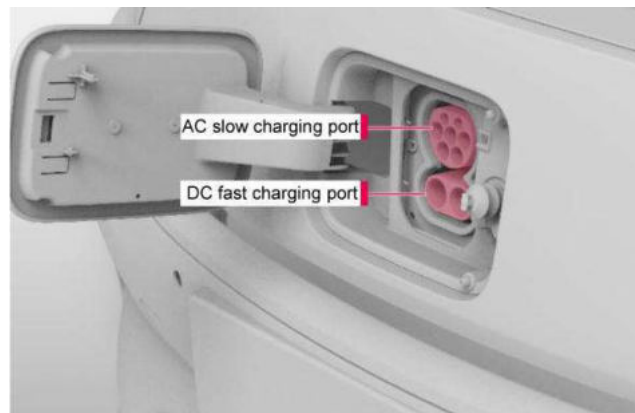

The charging port is located in the front of the vehicle.

Unlock the vehicle, slightly press the right side of the outer cover plate of the charging port, and open the charging port.

Close the outer cover plate of the charging port, and close the charging port.

CHARGING METHOD

BEFORE CHARGING

Please check whether the charging connection device is in good condition before charging.

CHARGING OPERATIONS

1. After stopping the vehicle completely, shift the gear to the "P" gear, apply parking brake, slightly press the right side of the charging port plate located in the front of the vehicle, and then open the charging port plate when it bounces up.



2. If using AC slow charging, remove the cap from the slow charging port.

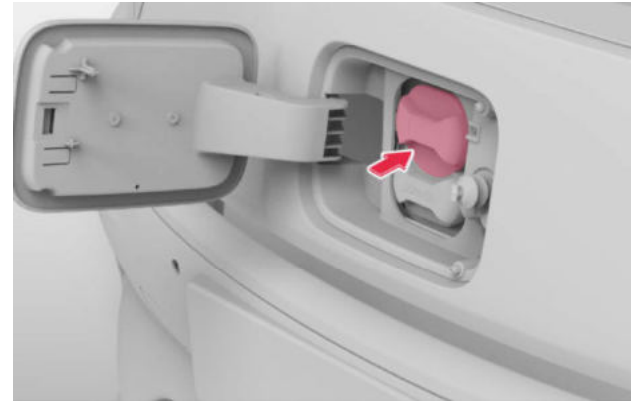

If using DC fast charging, remove the caps from the slow charging port and then from the fast charging port.

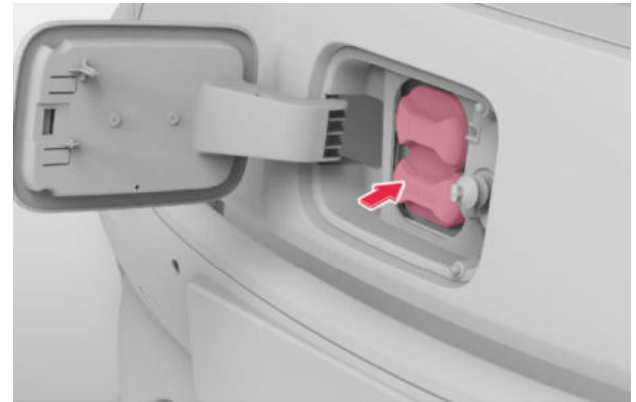

Charging

3. Open the charger protection cover, and make sure there are no obstacles at the charging connector and charging port. Insert the charger into the charging port.
4. Connect the power supply or start the charging pile to initiate charging.

CHARGING

During charging, the charging connection indicator lamp on the instrument cluster goes on, and the charging screen is displayed.

NOTE

- Do not forcibly pull out the charger during vehicle charging to avoid safety incidents.

CHARGING COMPLETE

When the vehicle charging is completed, the “Charging Completed” is displayed on the instrument cluster.

PULLING OUT CHARGER

After AC slow charging is complete, unlock the vehicle within 30s and pull out the charger from the AC slow charging port of the vehicle.

NOTE

- If the charger is not pulled out within 30s of vehicle unlocking, the charger will be locked again and can not be pulled out until it is unlocked again.

Tap Charger Unlock to unlock the charger in the Vehicle Control - Quick Control interface or Side slide bar interface on the Infotainment Screen. After the charger is unlocked, pull out the charger from the AC slow charging port of the vehicle.

When the vehicle charger cannot be unlocked by tapping Unlock Charger in the Vehicle Control - Quick Control interface or Side Slide Bar interface on the Infotainment Screen, toggle the manual unlocking switch on the charger to try to pull out the charger. (For details, refer to the [Urgent unlocking/locking](#) (page 208) section.)

After DC fast charging is completed, the charger can only be pulled out after charging is stopped on the charging pile.

NOTE

- After charging, if you can not pull out the charger, do not forcibly pull out the charger, and it is recommended to contact the authorized dealer.
- After disconnecting the charger, mount the charging port cap, close the charging port plate, and place the charger back.
- Make sure the charging connector is disconnected from the charging port when the vehicle is running.
- The above charging method is a general description and may vary slightly from the instructions provided by the specific charging equipment and charging piles. Please follow the instructions of charging equipment and charging piles during actual charging.

TIMED CHARGING

To facilitate the use of your vehicle, the timed charging function can be set on the Vehicle Control-Charging Settings interface on the Infotainment Screen. On the Charging Settings interface, enable the regular charging and configure the start time and charging limit.

NOTE

- During daily use, the timed charging mode is recommended, which will help extend the lifespan of the traction battery and delay its degradation.
- Timed charging is only applicable to the scenarios where AC chargers are used to charge the vehicle.
- The scheduled charging function supports Leapmotor's official slow charging piles, onboard chargers, and some compatible slow charging piles.

TRAVEL PREPARATIONS



TRIP PLANNING

PRE-DRIVING INSPECTION

Checking the vehicle before driving will help to travel safely and improve the fun of driving.

- Check whether the tires are damaged, whether the tire pressure is normal, and whether the tire treads have foreign matters, and take corrective measures when necessary.
- Check whether the wheel nuts are loose.
- Make sure all windows, rearview mirrors and exterior lamps are clean and uncovered. In cold weather, remove the frost or snow accumulated on them.
- Check whether there are abnormal phenomena such as water or other liquid leakage in the chassis of the vehicle. (It is normal for water to accumulate under the vehicle after using the A/C.)
- Before a long journey (beyond the vehicle's mileage), check the available charging points along your route/destination.

VEHICLE UNLOCKING



Vehicle Unlocking

KEYS

KEY FOB



The vehicle is equipped with a key fob (including a mechanical key in it). Through the key fob, the following operations can be achieved:

- Door locking/unlocking.
- Open the rear trunk.
- You can use custom settings to achieve functions such as One-key Vehicle Locating/One-key Lowering Window/One-key Turning on A/C, which can be set in the Vehicle Control - Key Setting interface on the Infotainment Screen.

The remote control transmitter and battery are integrated in the key. The wireless receiver is installed in the vehicle. When the battery power is sufficient, the key fob works within the range of 50m, but if there is an obstacle between the vehicle and the key

fob, in bad weather conditions or when the battery power is insufficient, the range of action will be reduced.

Functions such as locking or unlocking all doors with the key fob may be unstable or blocked under the following circumstances:

- The equipment nearby is emitting strong radio waves.
- Carry the key fob with an electronic device, laptop, mobile phone or wireless signal transmitter.
- The metal object touches or covers the key fob.

Key fob battery consumption description:

- The communication between the key fob and the vehicle will consume the battery power of the key fob.
- The battery life is about 1.5 years, depending on the frequency of daily use.
- Strong radio waves can affect the battery consumption, so do not place them near televisions and personal computers.

⚠ WARNING

- Do not leave children or animals alone in the vehicle, otherwise fortuitous or even life-threatening incidents may occur because they are unable to leave the vehicle on their own.
- When carrying the key fob, do not press any keys on the key fob on the plane or near the airport to avoid interfering with the work of the plane.
- If the key fob is lost or damaged, it is recommended to contact the authorized dealer as soon as possible to avoid vehicle theft or accidents.
- People with implanted pacemakers or cardiac defibrillators shall stay away from the detection antenna because electromagnetic waves will affect the normal use of such devices. Users of other electronic medical devices shall also consult the manufacturers about the use of such devices under the effect of electromagnetic

waves. Electromagnetic waves may cause unknown consequences for the use of such medical devices.

ⓘ ATTENTION

- The key fob is an electronic part, please avoid hitting, dismantling or placing it in a place of direct sunlight, high temperature, humidity and strong vibration.
- Do not drop the key fob from a height or place heavy objects on it.
- Do not use the key fob to knock on other objects.
- Do not touch the key fob with liquid or clean it in an ultrasonic scrubber. Wipe it with a soft cloth immediately if it is wet.
- Do not stick anything to the surface of the key fob.
- Do not place the key fob with devices that emit electromagnetic waves, such as mobile phone.
- Do not change the transmission frequency or increase the transmission power (including additional transmission frequency amplifier) without authorization. Do not use external detection antennas or switch to other transmit detection antennas without authorization.
- Do not put the key fob close to or in contact with metal or magnetic materials.
- Do not attach any objects (such as metal seals) that will cut off electromagnetic waves to the key fob.
- Do not interfere with other legitimate radio communication services when using the key fob. Once you find the interference, you should stop using it and take measures to eliminate the interference before continuing to use it.
- Do not expose the key fob to high or low temperature for a long time.
- The use of micro-power radio equipment must be kept away from the interference of various radio services or the radiation interference of industrial, scientific and medical application apparatus.

INTRODUCTION TO BUTTONS

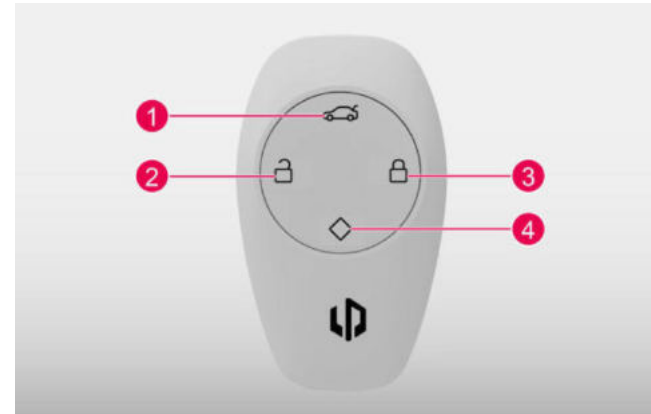

1. Open rear trunk
2. Unlock
3. Lock
4. Custom

 Lock key: When all doors are closed and the vehicle is stationary, pressing the Lock key will lock the vehicle, and all direction indicator lamps will flash once.

Remote window lifting: Press and hold the Lock button, all the windows are lifted automatically. Press the Lock or Unlock button again, the windows stop moving.

 Unlock button: When the vehicle is still, press the Unlock button, the vehicle will be unlocked, and the direction indicator lamps will flash twice.

Vehicle Unlocking

Remote window lowering: Press and hold the Unlock button, all the windows are lowered automatically. After releasing the button, the windows stop moving.

🔑 Trunk opening key: When the vehicle is stationary, pressing and holding the key for about 2s will open the trunk.

◇ Custom key: In accordance with the custom setting, you can achieve functions such as one-key vehicle locating/one-key lowering window/one-key turning on A/C of the vehicle. The custom function of the key fob can be set in the Vehicle Control - Key Setting interface on the Infotainment Screen.

⚠️ WARNING

- Before using the key fob to close the window, check and ensure that the electric window does not pinch the occupants in the closing process, and make sure that the window is closed correctly.

MECHANICAL KEY

The mechanical key is located in the key fob. If the key fob does not work, you can use the mechanical key to lock or unlock the driver's side door, but the vehicle can not be started.

1. Use the appropriate tool to gently slide along the opening gap at the bottom of the key fob to the outer edges of both sides, pry up and remove the rear cover of the key fob.



2. Take out the mechanical key.



3. After using the mechanical key, put it in the same place, install the bottom cover of the key fob and press it into place.

BLUETOOTH KEY

The Bluetooth key is integrated into the Leapmotor App, allowing users to unlock/lock the vehicle at close range when the network is unavailable or the remote unlocking function of the App cannot be used.

USE OF BLUETOOTH KEY

1. Please make sure the App Bluetooth unlocking/locking function is enabled in the Vehicle Control - Intelligent Interconnection interface on the Infotainment Screen.

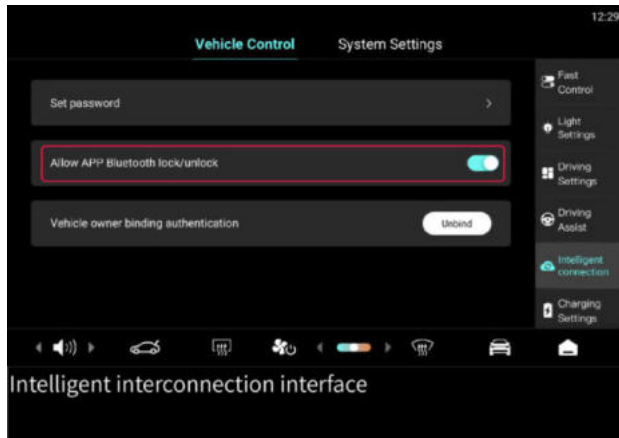

2. According to tips given in the Leapmotor App, use the Bluetooth key to lock/unlock the vehicle.

NOTE

- Please register and bind your vehicle in the Leapmotor App first, for details, please refer to the [Owner binding authentication](#) (page 37) section.
- If you need to use the Bluetooth key, please turn on the Bluetooth function on the phone and in the MMI first.
- Bluetooth key does not support multiple mobile phones connected to the vehicles at the same time.
- In case of Bluetooth connection problems, please follow the tips on the interface.
- For Bluetooth connection failures on different mobile phones or due to the wrong password, etc., there will be different tips in different scenarios.

VEHICLE LOCATING

VEHICLE LOCATING WITH KEY FOB



With the vehicle parked and all the doors locked, if you press the custom key on the effective key fob within the effective distance

Vehicle Unlocking

of the key fob, the direction indicator lamp flashes for about 25s, and the horn sounds 2 times to remind you of the exact location of the vehicle. You can repeat the one-key locating function. When any door is opened or unlocked/locked again, the locating function is cancelled immediately.

NOTE

- For one-key vehicle locating by using the custom key on the key fob, please set it in the Vehicle Control - Key Setting interface on the Infotainment Screen.

UNLOCKING FROM OUTSIDE

UNLOCKING WITH KEY FOB



When all the doors are locked, press the Unlock key of the key fob within the effective distance of the key fob, all the doors are unlocked, and the direction indicator lamps flash twice.

ENTERING THE VEHICLE



Entering the vehicle

OPEN THE DOOR

EXTERIOR DOOR HANDLE



After the vehicle is unlocked, pull the exterior door handle to open the door directly.

WELCOME LIGHTING

FRONT ROW LIGHTING

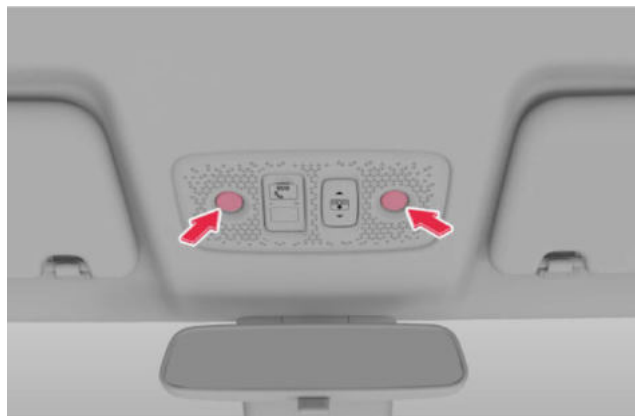

When the reading light is off, open any vehicle door, the reading light will go on for a period of time and then go off automatically.

Manually turn on the dome lamp: When the dome lamp is off, press the left/right dome lamp, it will go on, and press it again, it will go off. Turn on or off the reading light in the Vehicle Control - Light Settings on the Infotainment Screen. For details, please refer to [Lamp switch](#) (page 140) section.

NOTE

- The figure shows the dome lamp panel of some models. For details, please refer to the real vehicle.

IDENTITY AUTHENTICATION



Identity authentication

OPERATION PASSWORD

SET OPERATION PASSWORD

Please follow the steps below to set the operation password for the vehicle:

1. Tap the Vehicle Control-Intelligent Interconnection on the Infotainment Screen to enter the Intelligent Interconnection interface.
2. Tap Set Operation Password to enter the Set Operation Password interface. Enter the same 4-digit password twice, and the Infotainment Screen prompts "Operation Password Set Successfully".

NOTE

- Please keep your operation password secure.

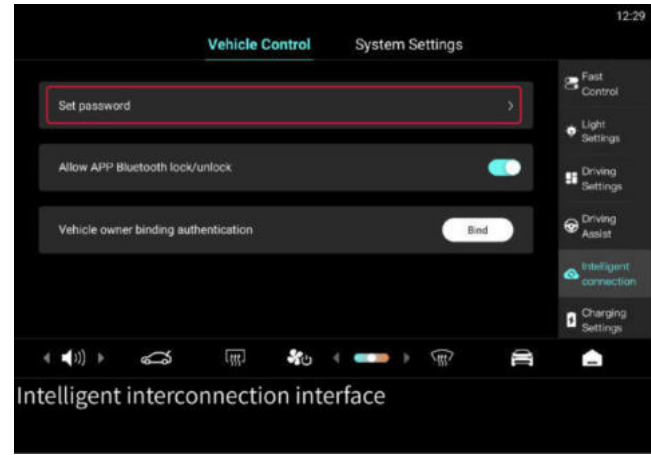

MODIFY OPERATION PASSWORD

For modifying the operation password, tap the Vehicle Control-Intelligent Interconnection on the Infotainment Screen to enter the Intelligent Interconnection interface.

1. Tap Modify Operation Password and enter the password modification interface.

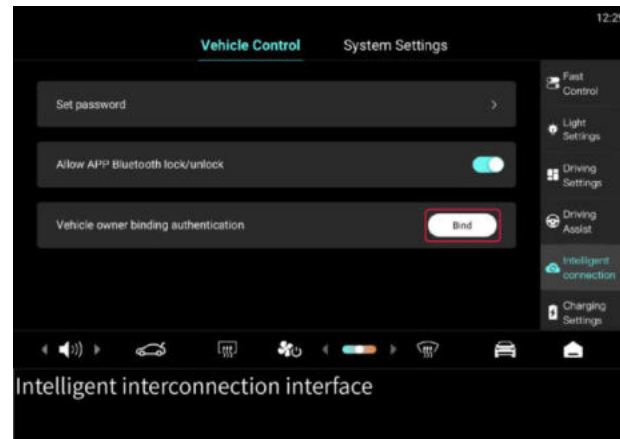
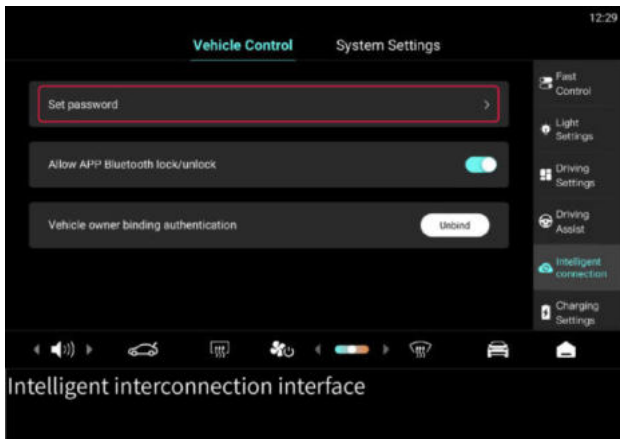

2. Following the prompts on the Infotainment Screen, enter the old password, then enter the new password twice. The Infotainment Screen displays "Operation Password Modified Successfully".

BINDING THE VEHICLE ON LEAPMOTOR APP

OWNER BINDING AUTHENTICATION

The owner binding authentication procedure is described as follows.

1. On the Vehicle Control-Intelligent Interconnection interface on the Infotainment Screen, tap the Owner Binding Authentication to enter the Binding interface. Then enter the operation password, and the vehicle QR code interface will pop up.

2. Place the QR code displayed on the Infotainment Screen inside the Leapmotor App scanning box. The App automatically recognizes the QR code. Please complete the registration certification in the App to bind the vehicle.

After successful binding, you can check your vehicle's status on the Leapmotor App interface. Additionally, you can remotely perform operations such as unlocking the vehicle, locking the vehicle, opening the trunk, turning on the A/C, honking to locate the vehicle, etc.

NOTE

- If you want to use the Leapmotor App to operate the vehicle, please make sure that the vehicle is connected to the network.
- Remote control via the Leapmotor App can only be used when the vehicle is not started. Once the vehicle is started, operating the vehicle via the Leapmotor App will be disabled.

UNBINDING

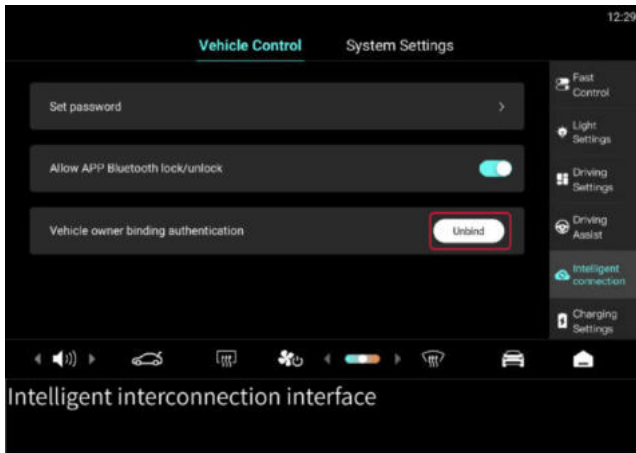

In the Vehicle Control-Intelligent Interconnection interface on the Infotainment Screen, tap Unbind in the Owner Binding Authentication interface, enter the operation password to remove the authentication.

NOTE

- If the owner's authentication is unbound, the vehicle information will no longer be displayed in the Leapmotor App.

LOADING THE VEHICLE



Loading the vehicle

OPEN REAR TRUNK

OPEN REAR TRUNK

There are three common ways to open the rear trunk: Open with key fob, open with liftgate switch, and open from the Infotainment Screen. After the rear trunk is opened, the rear trunk opening state will be displayed in the instrument cluster.

OPEN REAR TRUNK WITH KEY FOB

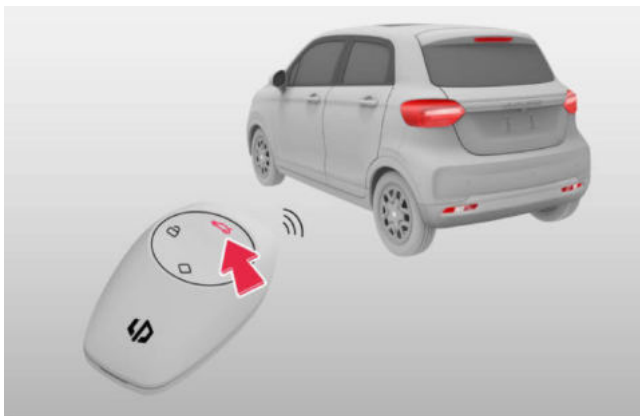

Within the effective distance of the key fob, press and hold the rear trunk opening button on the key fob for more than 2s until you hear the "click" sound of liftgate unlocking, then the rear trunk is opened.

OPEN REAR TRUNK WITH LIFTGATE SWITCH

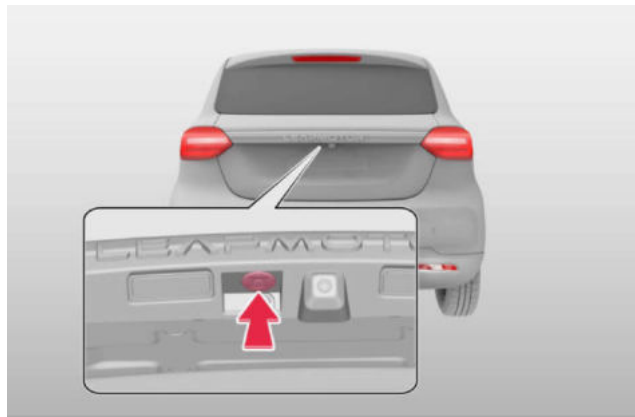

When the vehicle is unlocked and still, press the liftgate switch until you hear the "click" sound of liftgate unlocking, then the rear trunk is opened.

OPEN THE REAR TRUNK ON INFOTAINMENT SCREEN

Touch and hold the Open the Trunk shortcut key  in the bottom bar of the Infotainment Screen for more than 2s until you hear the "click" sound of liftgate unlocking, then the trunk is opened.

WARNING

- Do not open the trunk with a significant load (such as snow, ice, etc.) on the liftgate to avoid vehicle damage or safety accidents.
- When opening the rear trunk, pay attention to avoid people or obstacles within the range of motion of the liftgate.

- Do not operate the rear trunk while the vehicle is running.
- Do not let anyone travel inside the rear trunk.
- Do not let children play in the rear trunk while the vehicle is running.

ⓘ ATTENTION

- Do not install any accessories on the liftgate to avoid liftgate failure.
- Be careful when opening the liftgate in a strong wind. Under the action of strong wind, the liftgate may be opened too much, resulting in liftgate deformation.
- If the liftgate is frozen or covered with ice and snow, do not forcibly open the liftgate. You can turn on the warm air and wait for the temperature in the vehicle to rise before opening the liftgate. In case of emergency, when the liftgate must be opened immediately, you can pour warm water to melt the ice and snow, and open the liftgate after the icing position is loosened.

FOLDING OF REAR SEAT BACK

To get more storage space in the rear trunk, fold the rear seat back.

1. Press the headrest lock button while pressing down on the headrest to the lowest position, and then release the locking button.

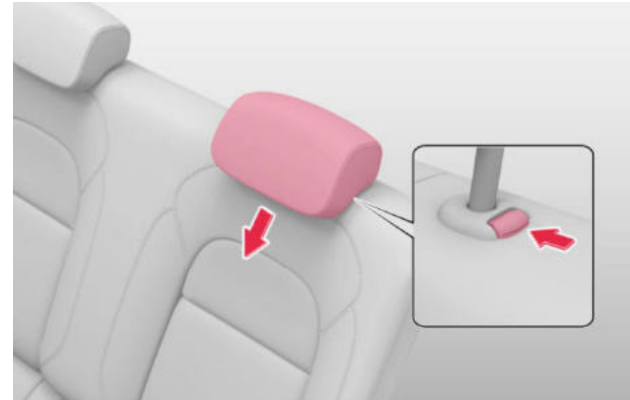

2. Pull the seat back folding switch from the rear trunk, unlock the rear seat back fixture, and fold the rear seat back forward to get more trunk space.



Loading the vehicle

Rear seat back restoration: Push back the folded rear seat back hard until you hear a "click" sound, then the rear seat back is locked in place.

ATTENTION

- When folding the rear seat, make sure there is nothing on the rear seat and that the seat belt is not connected, otherwise the rear seat may be damaged.
- When folding and restoring the rear seat back, you should operate slowly to avoid damage or abnormal function of the rear seat belt caused by folding the back quickly.

EASY LOADING

REAR TRUNK LAMP



When the rear trunk is opened, the rear trunk light goes on automatically.

When the trunk is closed, the rear trunk light goes off automatically.

ITEM LOADING

Please follow the following steps to load the items:

- All luggage or articles shall be firmly fixed in the rear trunk, so as not to affect the driving performance and safety of the vehicle.
- Place heavier luggage in the front position of the rear trunk as much as possible.
- Do not overload.
- No passengers are allowed in the rear trunk area.
- Before opening the rear trunk and loading luggage, ensure that the surrounding space for opening the rear trunk and loading luggage is large enough to avoid bumping.

WARNING

- Store your items properly and secure them firmly before driving; otherwise they may slip, overturn or be thrown up during braking or sudden turning, resulting in incidental injury.

ATTENTION

- When storing liquid items, pay attention to sealed storage to avoid damage to the vehicle caused by liquid leakage. If leakage occurs, clean it up in time.

CLOSE REAR TRUNK

CLOSE REAR TRUNK



Hold the liftgate handle and pull the liftgate down. When the liftgate falls to the appropriate position, press the liftgate quickly with both hands until the liftgate is locked.

⚠ WARNING

- When closing the rear trunk, pay attention to avoid people or obstacles within the range of motion of the liftgate.
- The rear trunk must be closed when the vehicle is driving; otherwise serious casualties may be caused.
- When closing the rear trunk, special care shall be taken to prevent pinching.
- When the liftgate is opened/closed in strong wind weather, the liftgate may suddenly move due to strong wind.

ⓘ ATTENTION

- Load the luggage reasonably according to the space in the rear trunk. If it is too full, do not forcefully press to close the liftgate; otherwise it may cause damage to luggage or deformation of the liftgate.

RIDING



SEAT BELT

PROTECTIVE EFFECT OF SEAT BELTS

Before each trip, every occupant in the vehicle must fasten their seat belts, and suitable child safety seats shall be provided for the accompanying children.

Both the vehicle and passengers during the driving process have kinetic energy. The strength of kinetic energy depends on the vehicle speed, the mass of the vehicle and passengers. The higher the speed and mass, the stronger the energy released during a collision.

After a vehicle collision, the driver and passengers who have not fastened their seat belts may still move forward due to inertia at the speed before the collision, and at this time, the vehicle may not move with the driver and passengers, which may cause serious injuries to the driver and passengers.

In the event of a collision, the seat belts that have been fastened can restrain the driver and passengers in a suitable position, slow down their forward motion inertia to prevent them from being thrown out, and ensure that the driver and passengers receive the best protection from the airbag, minimizing the impact injuries they may suffer.

WARNING

- Even if the speed is very low, the force acting on the human body in case of collision is very significant, so the driver and passengers can't control their bodies by hand, and the driver and passengers who don't wear seat belts may be thrown out, which may cause serious personal injury if they hit anything in the vehicle.

- Rear passengers must also wear seat belts correctly. Otherwise, they may be violently thrown out when an accident occurs. The rear passengers who do not wear seat belts will not only hurt themselves, but also endanger other passengers in the vehicle.
- The seat belts shall be kept clean, and the seat belt buckles shall not be blocked by foreign bodies; otherwise the reliable engagement of the seat belt buckles may be affected.
- Do not insert anything similar to a lock piece into the seat belt buckles to prevent the alarm when the seat belts are not fastened.
- Do not install ornaments or devices to prevent the seat belts from locking to avoid the failure of the seat belts to protect in case of accidents.
- Do not tilt the seat back too much, otherwise the protective effect of the seat belt will be seriously affected.
- Do not let children play with seat belts to avoid accidental injuries.
- The passengers suffering from diseases, disabilities, etc., are recommended to use seat belts, or also consult doctors for effective advice.
- Do not bleach or dye the seat belt, otherwise it will seriously weaken the strength of the seat belt. The cleaned seat belt shall be wiped clean and dried in a cool place.
- Do not place cushions between the driver and passengers' bodies and seat backrests, because the cushions placed will affect sitting posture and reduce the protective effect of seat belts.
- Children should sit in the rear seats and use appropriate child protection devices until they are big enough to wear seat belts.

CORRECT SITTING POSTURE

CORRECT SITTING POSTURE OF THE DRIVER



Correct driving posture is beneficial for driving operations and can reduce driver fatigue.

For the safety of the driver and passengers, it is recommended that the driver shall:

- Adjust the driver's seat position for easy and effective operation of pedals and control switches.
- Adjust the driver's seat backrest so that the driver's back fully fits the seat backrest.
- Adjust the steering wheel to a distance of at least 25cm from the chest and to hold the steering wheel when the arms are naturally bent.
- Wear the seat belt correctly.

CORRECT SITTING POSTURE OF THE FRONT PASSENGER

In order to ensure the safety of the front passenger and reduce the risk of incident casualties, it is recommended that the front passenger shall:

- Adjust the seat position of the front passenger so that the front passenger keeps a proper distance from the instrument panel.
- Adjust the front passenger's seat backrest so that the front passenger's back fully fits the seat backrest.
- Wear the seat belt correctly.

⚠ WARNING

- During driving, the feet of the front passenger shall be placed in the foot area below the instrument panel. Please do not put your feet on the instrument panel, put your hands out of the window or hunker on the seat; otherwise serious injuries may be caused in case of emergency braking or incident.

CORRECT SITTING POSTURE OF REAR OCCUPANTS

In order to ensure the safety of the driver and passengers and reduce the risk of incident casualties, it is recommended that the rear occupants shall make the following adjustments:

- Maintain a correct sitting position, and make the back fits completely with the seat backrest.
- Wear the seat belt correctly.

⚠ WARNING

- The appropriate child safety seat must be used in case of a child on the rear row.

PROPER USE OF SEAT BELTS

WEAR THE SEAT BELT CORRECTLY

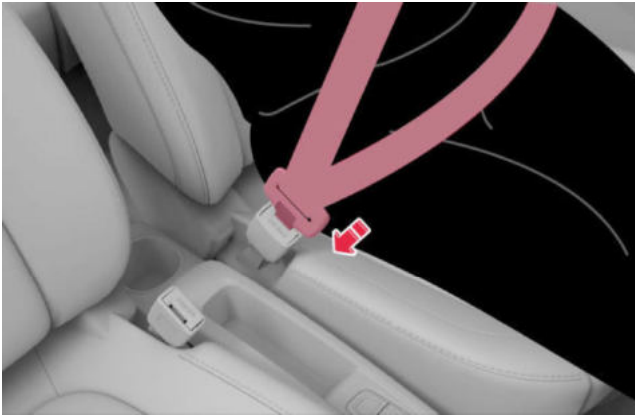

All seating positions in the vehicle are equipped with three-point seat belts, which shall be worn correctly according to the following methods:

1. Adjust the correct sitting posture.
2. Slowly and smoothly pull the seat belt out of the retractor, bypass the chest and hip, and insert the locking latch into the corresponding buckle until you hear a click sound.
3. Pull the seat belt latch to confirm that the seat belt latch is correctly engaged.
4. Adjust the seat belt position so that the belt slants across the shoulder, but does not touch the neck or slide off the shoulder, and the belt is as low as possible across the hip.

WARNING

- If the seat belt part is too high or too loose, it may cause serious injury or even life-threatening injury to occupants due to body sliding in the event of a collision or other incident.
- Do not place the seat belt under your arm to avoid the failure of the seat belt to protect in case of an accident.
- Each seat belt is limited to one person. Do not share a seat belt with more than one person (including children).
- Seat belts are for adult occupants only. Children should sit in the rear seats and use appropriate child protection devices until they are big enough to wear seat belts.

RELEASING SEAT BELT

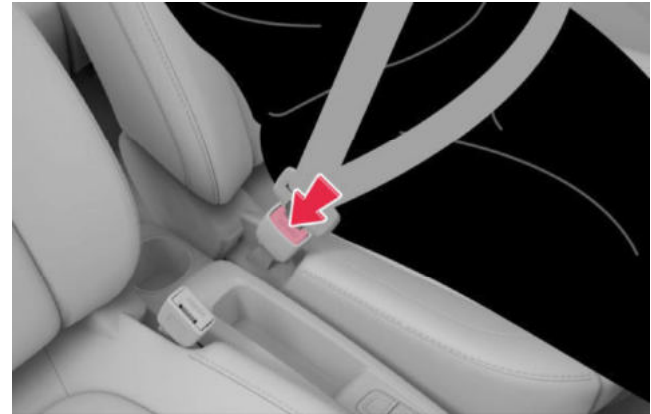

1. Press the red release button on the seat belt buckle, and the seat belt latch pops out.
2. Slowly return the seat belt to the retractor.

WARNING

- It is forbidden to release the seat belt during driving or before stopping completely to avoid serious injury in case of an incident.
- When releasing the seat belt, it is recommended to hold the seat belt before pressing the release button to prevent the seat belt from retracting too fast and causing damage to vehicle components or personal injury.

NOTE

- Ensure that the seat belt rewinding is smooth. If the seat belt cannot be rewound smoothly, pull out the seat belt and check whether it is distorted or twisted.

SEAT BELT PRETENSIONERS*

When the vehicle is subject to a serious head-on collision, the seat belt pretensioners will quickly tighten the seat belts, slow down the inertial motion of the driver and passengers, and reduce the impact injury of the driver and passengers as much as possible and protect the driver and passengers.

In the event of a minor head-on collision, side collision, or rear-end collision, the pretensioners may not be activated.

WARNING

- In the event of an incident, the seat belt pretensioners shall be replaced immediately once triggered. In some incidents, even if the seat belt pretensioners are not triggered, it is recommended to contact an authorized dealer for check and repair and replacement if necessary.
- When a seat belt pretensioner detonates, it will make a loud noise and emit white smoke. Do not touch the seat belt pretensioner after detonation to avoid scalding.

SEAT BELT REMINDER WARNING LAMP



The seatbelt reminder warning lamp is used to remind occupants: Please fasten your seat belts before driving.

The power supply of the vehicle is in the "READY" state, and when there is a driver and passengers in the vehicle but not wearing a seat belt, the driver and passengers will be reminded in the following ways:

- The corresponding unfastened seat belt warning indicator is lit on the instrument display. (For details, refer to the section of [Instrument cluster indicator lamps and warning lamps](#) (page 96)Driving - View Instrument cluster - Instrument cluster indicator lamps and Warning Indicators.
- Buzzer tone.

HOW DO PREGNANT WOMEN USE SEAT BELTS

Pregnant women have to pay more attention to their own safety and the safety of the unborn fetus and much wear seat belts properly when driving or traveling in vehicles.

When wearing a seat belt, pregnant women should slowly and smoothly pull out the seat belt from the retractor, bypass the chest and hip, and ensure that the seat belt is as low as possible, instead of pressing on the abdomen to avoid affecting the unborn fetus.

NOTE

- As the pregnancy grows, you should adjust the seat and steering wheel to make it easier to maintain control of the vehicle. In this case, you should try to adjust the seat position so that the distance between the abdomen and the steering wheel is as large as possible.

SEAT BELT SYSTEM INSPECTION

Please inspect the seat belt system regularly:

- Always inspect that seat belt warning lamps, seat belts, buckles, latches, retractors, and fixtures are working properly.
- Check the seat belt system for other looseness or damage, and check for items that may affect the normal operation of the seat belt system.
- If a seat belt is cracked or worn, replace it immediately.
- Keep seat belts clean and dry.

REPLACEMENT OF SEAT BELT SYSTEM COMPONENTS

If the seat belt system does not work properly, contact the authorized dealer. Do not use the corresponding seat until its seat belt is repaired.

The seat belt system (including bolts) used by the vehicle in serious collision accidents must be replaced. The whole assembly shall be replaced even if it is slightly damaged.

WARNING

- Do not install, remove, refit, disassemble or scrap the seat belts without permission. When maintenance is needed, it is recommended to contact the authorized dealer.
- Please use the seat belts provided by the original factory, otherwise serious safety hazards may occur.

AIRBAG

PROTECTIVE EFFECT OF AIR BAGS

Airbags are a part of the entire passive safety protection system of the vehicle and a supplement to seat belts. Only when working with correctly worn seat belts can airbags provide maximum protection.

Airbags are developed for specific vehicle models, and modifications to suspension, tires, bumpers, chassis, and original factory components can have adverse effects on airbags. Do not use any components of the airbag on other vehicles, as this may cause the airbag to fail and cause personal injury.

Any accessories such as mobile phone holder, cup, Ashtray and so on are prohibited to be installed on the trim cover of the airbag or

within its scope of action; otherwise, in case of an incident, the deployment of the airbag will increase the risk of injury to the driver and passengers.

⚠ WARNING

- When the vehicle encounters a serious collision, the airbags will quickly deploy in a very short time, so the driver and passengers must maintain the correct sitting posture and wear seat belts to avoid serious injury. In case of emergency braking in an emergency situation, the driver and passengers who have not fastened their seat belts may be thrown forward into the airbag deployment area, and high-speed deployment of the airbag may cause injuries to the driver and passengers and even endanger their lives.
- Do not stack items within the airbag deployment area (instrument cluster area/front passenger's seat), as these items may harm the driver and passengers when the airbag is deployed.
- Front occupants are not allowed to hold children, pets, or items. If the airbag is triggered during an accident, it may cause serious injury or even endanger life.
- Do not place feet, knees, or any other part of the body above or near the airbag to avoid personal injury when the airbag is deployed.
- The airbag system has strong anti-interference ability to the surrounding electromagnetic environment. To avoid incidents, please do not use the vehicle in electromagnetic environments beyond the national permission.

LOCATION OF AIRBAGS

FRONT FRONTAL AIRBAG



The driver's frontal airbag is installed inside the steering wheel, and the front passenger's frontal airbag is installed inside the instrument panel. The steering wheel and instrument panel are marked with the words "AIRBAG".

In case of a frontal impact while driving, the frontal airbags will be deployed to assist in protecting the head and chest of the driver and the front passenger, in order to reduce their degree of injury.

⚠ WARNING

- When driving the vehicle, please maintain the correct sitting posture. If your body is too close to the steering wheel and instrument panel, you are susceptible to strong impact as the

Riding

airbag is deployed. It is recommended that the driver maintain a distance of more than 25cm from the steering wheel when driving.

FRONT SIDE AIRBAG



The front side airbags are installed on the driver and front passenger seat back sides (approximate area shown in the figure), with "AIRBAG" marked on the seat back.

In the event of a side impact, when the conditions for deploying the side airbags are met, the side airbags will deploy to protect the driver and front passenger's bodies.

SIDE CURTAIN AIRBAG



The side curtain airbags are located along the left and right sides of the vehicle headliner edge (approximate area shown in the figure) and are marked with "AIRBAG".

In the event of a moderate to severe side collision, when the conditions for deploying the side curtain airbags are met, the side curtain airbags will deploy to assist in protecting the occupants' heads.

DEPLOYMENT OF AIRBAGS

When a vehicle collides, whether the airbag is deployed or not is related to the collision direction and the deceleration of the vehicle caused by the collision. Whether the airbag is deployed or not should not be judged according to the damage degree of the vehicle.

Conditions where airbags may deploy:

- The front of the vehicle hits the ground as the vehicle crosses a deep potholed road.
- The vehicle hits a roadside bulge, curb etc.
- The front of the vehicle hits the ground as the vehicle goes down a steep slope.

Conditions where airbags may not deploy:

- The vehicle hits a cement pillar, trees or other slender objects.
- The vehicle does not hit another vehicle or the wall head on.
- The rear of the vehicle is hit by other vehicles.
- A truck is rear-ended by the vehicle.
- The vehicle rolls over.
- Minor collision ("Minor" is for the airbag electronic control unit or collision sensor of the vehicle, regardless of the degree of damage to the vehicle).
- The airbag system is faulty.
- Other special situations.

If the airbag is deployed during a collision, the airbag will expand due to hot air, and will deflate and shrink after being squeezed or compressed for a short time. When this happens, a small amount of dust (smoke) will be released and a loud noise may be emitted. This is a normal phenomenon and will not cause a fire. The smoke and dust generated during prolonged exposure to detonation may cause skin or eye discomfort. Please immediately rinse the affected area with clean water.

⚠ WARNING

- After the airbag is deployed, the airbag components will generate heat. Do not touch them to avoid burns.
- Do not strike the airbag components to avoid accidental deployment of the airbag.

- The airbag system has fully taken into account various common misuse and road conditions. To avoid accidents, do not allow the bottom of the vehicle to be hit or drive rough in harsh road environments.

AIRBAG FAULT WARNING LAMP



The vehicle is equipped with an airbag fault warning indicator to remind the driver of the status of the airbag system. For details, refer to the section of [Instrument cluster indicator lamps and warning lamps](#) (page 96).

REPLACEMENT OF AIRBAG SYSTEM COMPONENTS

If the airbag system can't work normally, it can't protect the driver and passengers in the vehicle when a collision occurs, resulting in serious injuries and even endanger lives. In order to ensure that the airbag system can work normally after a collision, the airbag should be checked regularly and replaced if necessary.

WARNING

- It is strictly forbidden to repair, adjust or modify airbag components, wiring harnesses and software without permission; otherwise the airbag system may not work normally, and may fail or start unexpectedly in case of an accident, increasing the risk of injury.
- If the airbag cover is broken or damaged, do not use the vehicle and contact the authorized dealer immediately.
- The airbag system deployed in a collision incident must be replaced.

VEHICLE DISPOSAL

When selling or transferring your vehicle, make sure that the new owner knows the airbags installed on the vehicle and the replacement date of the airbag system.

If the vehicle is scrapped, there is a potential danger in the undeployed airbags. Therefore, before vehicle scrapping, the airbags must be safely deployed by professional personnel in a certain environment.

CHILD SAFETY

INSTRUCTIONS FOR CHILDREN RIDING

Unlike adults, children's bones and muscles are not yet fully developed, making them more vulnerable to injury. To reduce the risk of injury, children shall use special child safety seats in vehicles.

The child safety seat shall be selected according to the child's height and weight, and the child safety seat instruction manual shall be provided in the vehicle along with the accompanying documents.

To provide proper protection, the child safety seat shall be used in compliance with the child safety seat manufacturer's instructions regarding the age, stature and size of the child for which the child safety seat is intended.

WARNING

- When using the child safety seat, comply with all installation instructions provided by the child safety seat manufacturer and install the child safety seat correctly. If it is not properly installed, in case of emergency braking, emergency turns or accidents, serious injuries or even life-threatening injuries to children may be caused.
- Make sure there are no hard or sharp objects on the child safety seats to avoid stabbing the children in case of an incident.
- Holding a child in your arms is no substitute for the role played by a child safety seat, and in the event of an incident, the child may hit the windshield or be crushed between the occupant and the vehicle.
- Children should be supervised by adults when sitting in child safety seats. Do not leave children alone in the vehicle to avoid incidental injuries.
- Children are forbidden to stand in the vehicle or kneel on their seats while driving; otherwise in the event of incidents, children may be thrown up, causing injury or even endangering the lives of children and other personnel inside the vehicle.
- The child safety seat, if not in use, must also be correctly installed and fixed in the vehicle to avoid injury to the driver and passengers in the vehicle due to the movement of the unfixed child safety seat in case of collision or emergency braking.

ATTENTION

- For effective protection of children, please select the correct child safety seat according to the child's age, height and weight,

and use the seat belt or child safety seat for restraint and protection.

NOTE

- Child safety seats are very binding and wrapped, so we must insist on using them after children are born, and develop the awareness and habit of accepting child safety seats from an early age. If they are used intermittently, children will probably get bored.

CHILD SAFETY LOCK

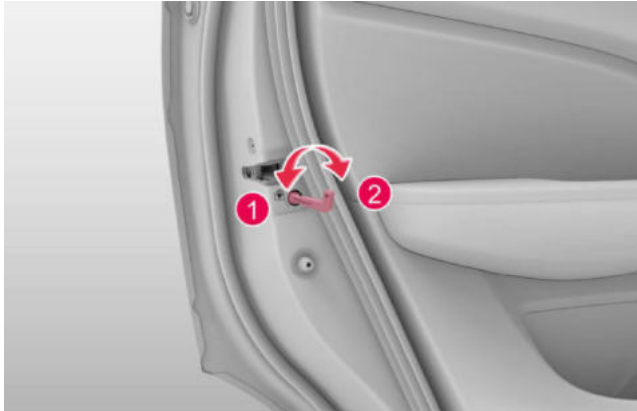

1. Unlock
2. Closure

The child locks are designed to prevent children sitting in the rear seats from unintentionally opening the rear doors, and the left and right rear doors are equipped with child locks.

When you use the mechanical key to toggle the child lock to the ON position ① (taking the left rear door as an example), the door will not be opened from inside, in this case, use the exterior door handle.

WARNING

- Before driving, if there are children riding in the rear seats, make sure the child locks are ON.
- After the child lock is enabled, the doors on both sides of the rear row cannot be opened from inside. At this time, the doors shall be unlocked and opened from outside. Do not pull the interior handles too hard to avoid damage.
- After the child lock is enabled, the rear door on the corresponding side cannot be opened from the inside. Do not leave the child alone in the vehicle to avoid incidental injury.

INSTALLATION OF CHILD SAFETY SEATS

When installing the child safety seats, always comply with local regulations and consult the manufacturer's manual. Place the child safety seat installation manual in the glove box for other personnel.



An airbag warning sticker on the front passenger's sun visor reminds the front passenger of the dangers of airbag deployment, and the rear-facing child restraint system shall not be used in seats protected by frontal airbags (in the activated state).



⚠ WARNING

- Do not install a rear-facing child safety seat on the front passenger's seat, otherwise, in case of an incident, the impact of the sudden deployment of the front passenger's airbag will cause serious injury and even life-threatening to the children.

Three-point seat belts and ISOFIX fixtures shall be used to secure child safety seats. The three basic child safety seats are as follows:

- Rear-facing child safety seat
- Forward-facing child safety seat
- Auxiliary seat

It is generally recommended that infants and toddlers under 3 years be placed in rear-facing child safety seats. For children over 3 years who are too large to fit into rear-facing child safety seats, forward-facing child safety seats can be used. For children who

are too large to fit into forward-facing child safety seats, auxiliary soft cushions can be used to fasten their seat belts.

INSTALLATION OF CHILD SAFETY SEAT WITH ISOFIX



There are 4 lower ISOFIX fixing connectors for the child safety seat at the gap between the rear seat backrest and the seat cushion to assist in the installation of child safety seat.



There are 2 child safety seat upper tether strap fixing points on the back side of the rear seat backrest.

Please follow the child safety seat installation manual and use the ISOFIX anchorage.

1. Move the front seat to the most forward position.
2. Adjust or remove the headrest of the seat where the child safety seat is installed.
3. Slide the child safety seat locking mechanisms into the lower fixation points to ensure that both ISOFIX locking mechanisms are properly secured.
4. Compress the retaining spring and then thread it through the fixing point on the rear side of the seat back. Be careful not to curl the upper tether. When securing, be sure to pass the upper tether straps under the seat headrest.

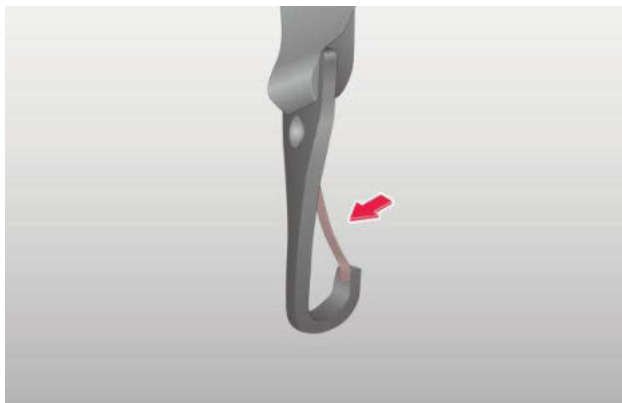

5. Push and pull the child safety seat in different directions to ensure that it is firmly installed.

⚠ WARNING

- Do not continue to adjust the child safety seat after the installation is completed; otherwise the child safety seat may shift and cannot play its protective effect.
- The fixation device of the child safety seat can only withstand the loads generated by a properly installed child safety seat.
- The fixing connector is only used to install the child safety seat applicable to the ISOFIX connector. Do not connect other objects to the fixed connector to avoid personal injury.
- Do not attach more than one child safety seat to a single seat belt or a single fixing connector. The added load of multiple seats can damage the seat belt or fixing connector, causing serious injury or even endangering lives.
- When using a child safety seat in the rear seat, the child safety seat must be fixed tightly against the seat.

- When using a child safety seat and seat belt, make sure the seat belt isn't slack or twisted.
- While installing the child safety seat, adjust or remove the headrest to ensure the passenger seat or headrest to provide adequate support for the child safety seat.
- After removing the child safety seat, the headrest must be remounted.
- There is no ISOFIX interface in the center of the rear seat of the vehicle. Any type of ISOFIX child restraint system is not allowed to be installed in this position. Do not install a forward-facing child safety seat with a tie-down strap in the center of the rear seat.
- Install the child safety seat with the seat belt in the position closest to the seat.

SELECTION OF CHILD RESTRAINT SYSTEM

Information on the applicability of different riding positions to child restraint system.

Mass group	Seat		
	Front passenger seat	Rear seat by window	Rear center seat
Group 0 (0~10kg)	X	U	X
Group 0+ (0~13kg)	X	U	X
Group I (9~18kg)	X	U/UF	X
Group II (15~25kg)	X	UF	X

Mass group	Seat		
	Front passenger seat	Rear seat by window	Rear center seat
Group III (22~36kg)	X	UF	X

The meaning of the letters given in the above table are as follows:

U = Applicable to universal child restraint systems approved by this mass group.

F = Applicable to forward-facing child restraint systems approved by this mass group.

X = Not applicable to child restraint systems of this mass group.

Information on the applicability of different ISOFIX positions to ISOFIX child restraint system:

Mass group	Size classes	Fixed module	Seat		
			Front passenger seat	Rear seat by window	Rear center seat
Carrycot	F	ISO/L1	X	X	X
	G	ISO/L2	X	X	X

Mass group	Size classes	Fixed module	Seat		
			Front passenger seat	Rear seat by window	Rear center seat
Group 0 (0~10kg)	E	ISO/R1	X	IL	X
Group 0+ (0~13kg)	C	ISO/R3	X	IL	X
	D	ISO/R2	X	IL	X
	E	ISO/R1	X	IL	X
Group I (9~18kg)	A	ISO/F3	X	IUF	X
	B	ISO/F2	X	IUF	X
	B1	ISO/F2X	X	IUF	X
	C	ISO/R3	X	IL	X
	D	ISO/R2	X	IL	X
Group II (15~25kg)	/	/	X	/	X
Group III (22~36kg)	/	/	X	/	X

The meaning of the letters given in the above table are as follows:

Riding

IUF = Applicable to universal forward-facing ISOFIX child restraint systems approved by this mass group.

IL = Applicable to ISOFIX child restraint systems recommended for use.

X = ISOFIX position is not applicable to ISOFIX child restraint system of this mass group or this size class.

Size classes and corresponding child safety seat descriptions are as follows:

Size class	Corresponding child safety seat description
A	Full-height forward-facing child safety seat for toddlers
B	Height reduced front-facing child seat for toddlers
B1	Height reduced front-facing child seat for toddlers
C	Full-size rear-facing child safety seat for toddlers
D	Reduced size rear-facing child safety seat for toddlers
E	Rear-facing child safety seats for infants
F	Left-facing infant seat (carrycot)
G	Right-facing infant seat (carrycot)

RIDING ON DRIVER'S SIDE

DRIVER SEAT ADJUSTMENT

MANUAL 6-WAY ADJUSTMENT OF THE DRIVER'S SEAT



Driver seat forward/backward adjustment: Pull up the adjusting lever, then gently lean against the seat, slide the seat to the desired position, and release the lever.

⚠ WARNING

- Be careful when adjusting the seat to ensure that it does not hurt other occupants when it moves.
- Don't place your fingers or other body parts under the seat, or you may get hurt by the seat.

NOTE

- Do not place items under the seat, as this may hinder the operation of the seat.
- After the front and rear positions are adjusted, slide the seat back and forth to make sure the seat is locked.

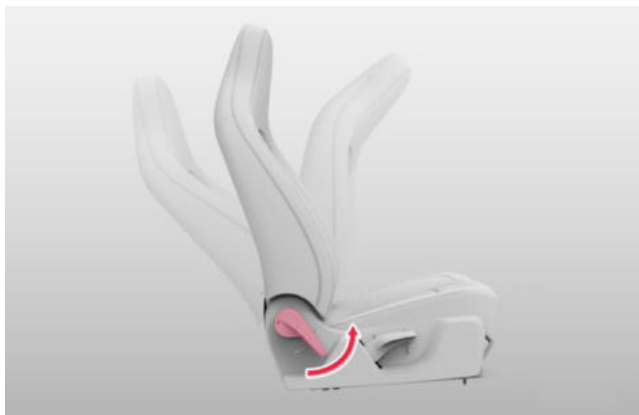

Driver seat backrest adjustment: Pull the lever up, use your back pressure to tilt the backrest forward or backward, adjust the backrest to the desired position, and release the lever.

WARNING

- When adjusting the tilt angle of the backrest, ensure your back is tightly against the backrest to prevent the backrest angle from changing too fast, which may cause unnecessary injuries.
- Don't adjust the seat during driving to avoid losing control of the vehicle due to seat movement.



Driver's seat height adjustment: Repeatedly pull the handle upward to gradually raise the seat. Repeatedly press the handle down to lower the seat gradually.

WARNING

- Don't adjust the seat while the seat belt is buckled up to prevent the seat belt from leaving the normal use condition, leading to injuries to the occupant and failure of the protective function.
- The seats must be replaced after the vehicle experiences a serious accident.
- Please use the original seat provided by the factory when replacing it, otherwise serious safety hazards may occur.

NOTE

Riding

- When the depth of the driver seat cushion is measured in the factory, the seat is located 10mm forward of the last position of the slider range (the maximum adjustment range of the front and rear positions is 210mm), the design angle of the backrest is 22° (with a forward tilt of 17° and a castor of 49°), and the height is at the lowest position (the maximum adjustment range of the height is 40mm).
- After adjusting the seat, push the seat and seat backrest forward and backward to make sure the seat and seat backrest are locked.

DRIVER'S SEAT DEPARTURE REMINDER

The vehicle is equipped with a driver's seat departure reminder function. When the power supply of the whole vehicle is in the "READY" state, if the driver leaves the seat, the instrument will display an alarm accompanied by a prompt tone to remind the driver to drive safely.

EXTERIOR REARVIEW MIRROR ADJUSTMENT

Before driving the vehicle, be sure to adjust the exterior rearview mirrors to the proper angle.

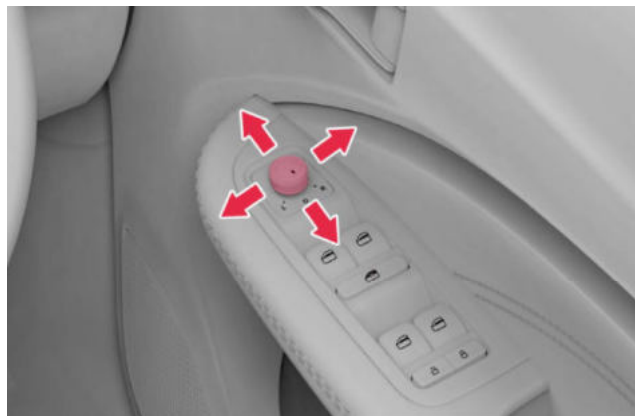

Adjust the mirrors to the proper position with the exterior rearview mirror power adjustment switch.

First turn the knob to "L" or "R" gear, select the left or right exterior rearview mirror, and turn the knob front, rear, left and right to adjust the lens to the right angle.

WARNING

- Do not adjust the exterior rearview mirrors during driving to avoid distractions that may cause the vehicle to lose control and become dangerous.

INTERIOR REARVIEW MIRROR ADJUSTMENT

INTERIOR REARVIEW MIRROR ADJUSTMENT

Before driving the vehicle, be sure to adjust the interior rearview mirror to the proper angle.

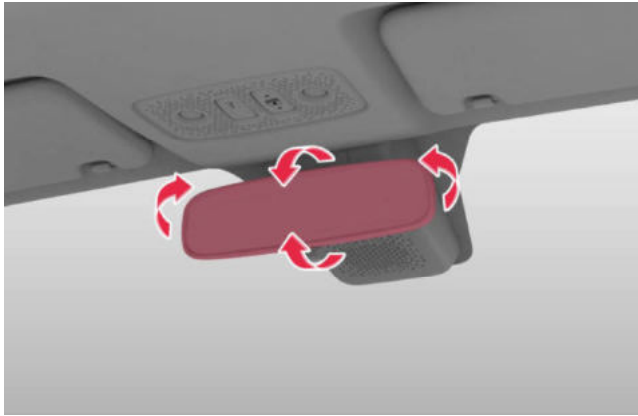

Turn the interior rearview mirror up and down, left and right, to the proper rearview position.

⚠ WARNING

- Do not adjust the interior rearview mirror during driving to avoid distractions that may cause the vehicle to lose control and become dangerous.
- Do not forcefully adjust the interior rearview mirror due to jamming when it is adjusted, so as not to cause the interior rearview mirror to fall off.

MANUAL ANTI-GLARE REARVIEW MIRROR



When the light from the rear vehicle is too strong, turn the mirror surface at an angle to prevent glare by pulling the flip grip at the lower end of the interior rearview mirror.

⚠ WARNING

- Please do not install anything around the interior rearview mirror to avoid affecting the driver's observation of road conditions.
- Do not hang heavy objects or shake or drag hard on the interior rearview mirror.

WINDOW CONTROL

POWER WINDOW SWITCHES

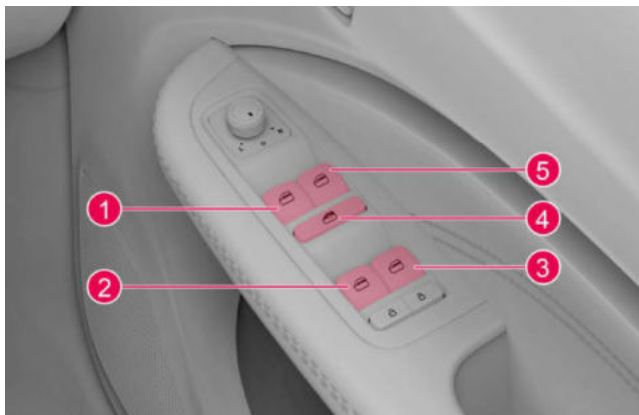

1. Left front power window control switch
2. Left rear power window control switch
3. Right rear power window control switch
4. Occupant window lock switch
5. Right front power window control switch

ROLL UP THE WINDOW



Manual window lifting: When the vehicle is powered on, gently pull up (in hold state) the window control switch to roll up the corresponding window. After the switch is released, the window stops movement.

Automatic window lifting: When the vehicle is powered on, pull up the window control switch to its limit position and then release it, and the corresponding window will automatically rise to its limit position.

WARNING

- When closing the windows, take care to avoid the occupant's body parts being caught in the closing windows, thus causing serious injury.
- Check that the windows are closed before leaving the vehicle.

- The driver shall be responsible for the operation of all power windows, including the operation of passengers. To prevent accidental operation (especially caused by children), do not let children operate the power windows; otherwise the power windows may clip children or other passengers. Besides, when there are children in the vehicle, it is recommended to turn on the passenger window locking function.
- Do not leave children alone in the car, otherwise they may cause serious personal injury or even endanger life due to the children's mistaken operation of the power window buttons.

ROLL DOWN THE WINDOW



manual window lowering: When the vehicle is powered on, gently press (in hold state) the window control switch to roll down the corresponding window. After the switch is released, the window stops movement.

Automatic window lowering: When the vehicle is powered on, you press the window control switch to its limit position and release it,

and then the corresponding window will lower to its limit position automatically.

NOTE

- In the process of automatic descending, pull up or press the control switch to any position to stop the automatic descending movement of the window.

ANTI-PINCH FUNCTION

When the window raises automatically, if it encounters certain resistance (blocked by foreign objects or human body pinched, etc.), the window will immediately stop and lower for a certain distance. When the anti-pinch function is triggered for 3 times continuously, the automatic raising and anti-pinch functions will be lost, during which the window can be rolled up or down manually, and now the window has no anti-pinch function.

WARNING

- Do not intentionally pinch a part of your body to activate the anti-pinch function.
- When closing the power windows, do not put your hands or other parts of your body within the running range of the window glass to avoid pinching.
- Notwithstanding anti-pinch protection, it is important to note that the running range of the window glass is unobstructed, and it is impossible to ensure that the anti-pinch function is activated under special circumstances (such as thin or soft obstacles).

NOTE

Riding

- When a window is blocked and reverses for no more than 3 times, the count is cleared to zero if the window can rise to its fully closed state.
- When driving on special road conditions, closing the windows may trigger the anti-pinch function.

MANUAL LEARNING

After the automatic window raising and anti-pinch functions are lost, all its functions can be restored by manual learning as follows:

1. Press the window control switch to lower the window to its limit position and then hold the pressing action for 1 second;
2. Then pull up the window control switch to raise the window to its limit position, and hold the pull-up action for 1 second to complete the manual window learning.

NOTE

- The windows cannot be stopped, stuck or subject to external forces during the raising process, or otherwise they need to learn again.
- After successful learning, the windows have full functionality.

WINDOW THERMAL PROTECTION FUNCTION

When a single window is operated continuously for about 30s, the window will enter the protection state, and the window will not be able to be operated at this time. After a period of time, the window will return to normal.

If you continue to operate the window frequently after protection, the window will enter the protection state again, and you need to wait longer to operate the window.

WINDOW LOCKING



After pressing the occupant window lock switch, all occupant side power window control switches except the driver's side will be disabled. To resume operation, you should press the occupant window lock switch again.

NOTE

- When children are present in the vehicle, it is recommended to have them seated in the rear child seats, and to activate the window lock and child safety lock functions.

LOCKING FROM INSIDE

LOCKING WITH CENTRAL CONTROL DOOR LOCK



When the vehicle is powered on and all doors are closed, you can lock the doors by pressing the Lock key on the central control door lock.

DOOR OPEN ALARM

When the vehicle is powered on, if any door is open, the instrument cluster will prompt the message of the open door, and when the vehicle speed reaches a certain value, the instrument cluster will start to issue a warning tone.

NOTE

- For driving safety, please make all preparations before you start your vehicle.

STEERING WHEEL CONTROL

STEERING WHEEL BUTTON INFORMATION (STATUS 1) *

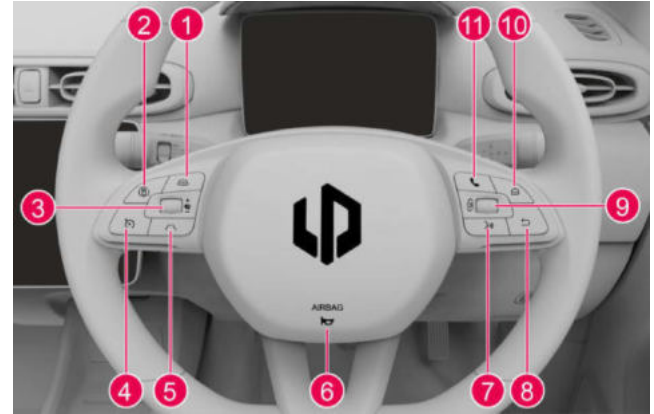

1. Following distance+: In the ACC state, press it to increase the following distance.
2. ADAS button: Tap it to turn on or off the LDW tone.
3. Left Scroll: Scroll it up to increase the volume, scroll it down to decrease the volume, press it to switch between mute or volume restoration; when setting the adaptive cruise control/cruise control speed, scroll it up to increase the set speed, scroll it down to decrease the set speed, with each scroll for 2km/h; if it is not operated within 2s, the setting will automatically take effect.
4. ACC keys: Tap it to enable adaptive cruise control/cruise control (it needs to be set in the Vehicle Control - ADAS - Cruise Assist in the Infotainment Screen). Please refer to the specific

operations in the [Cruise control system \(CCS\)](#) (page 111)/
[Adaptive cruise control \(ACC\)](#) (page 112)

- Following Distance: In the ACC state, press it to decrease the following distance.
- Horn mark: Press the steering wheel cover plate area to make the horn sound, and release to stop the sound.
- Voice button: Press to activate voice recognition. If the voice is not successfully recognized, press the voice button again to re-enable speech recognition.
- Back button: When the instrument cluster has a fault prompt, tap to hide the fault prompt; in the cruise setting status, tap to exit the cruise setting.
- Right Scroll: When playing music or radio via the IVI system, scroll up to switch to the previous song and down to the next song, and press to switch to Pause or Play; when no music or radio is played, press the right roller to play the previous media source.
- HOME key: Press this key, and the Infotainment Screen will return to the HOME interface.
- Phone answering key: When Bluetooth is not connected, press the Infotainment Screen to display the Bluetooth connection screen; when the call is not answered, short press it to answer the call.

STEERING WHEEL BUTTON INFORMATION (STATUS 2)*

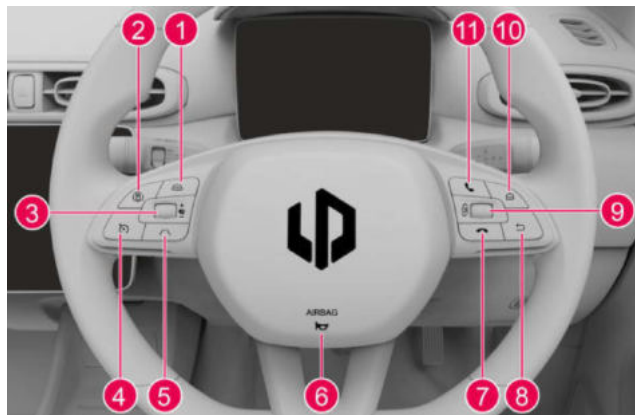

- Following distance+: In the ACC status, press it to increase the following distance.
- ADAS button: Tap it to turn on or off the LDW tone.
- Left Scroll: Scroll it up to increase the volume, scroll it down to decrease the volume, press it to switch between mute or volume restoration; when setting the adaptive cruise control/ cruise control speed, scroll it up to increase the set speed, scroll it down to decrease the set speed, with each scroll for 2km/h; if it is not operated within 2s, the setting will automatically take effect.
- ACC keys: Tap it to enable adaptive cruise control/cruise control (it needs to be set in the Vehicle Control - ADAS - Cruise Assist in the Infotainment Screen). Please refer to the specific operations in the [Cruise control system \(CCS\)](#) (page 111)/
[Adaptive cruise control \(ACC\)](#) (page 112)

5. Following distance: In the ACC status, press it to decrease the following distance.
6. Horn mark: Press the steering wheel cover plate area to make the horn sound, and release to stop the sound.
7. Phone Hang-up key: When the call is not answered, short press it to answer the call; during the call, press it to hang up the current call; when the call to another number is not answered, press it to hang up the call.
8. Back button: When the instrument cluster has a fault prompt, tap to hide the fault prompt; in the cruise setting status, tap to exit the cruise setting.
9. Right scroll: When playing music or radio via the IVI system, scroll up to switch to the previous song and down to the next song, and press to switch to Pause or Play; when no music or radio is played, press the right roller to play the previous media source.
10. HOME key: Press this key, and the Infotainment Screen will return to the HOME interface.
11. Phone answering key: When Bluetooth is not connected, press the Infotainment Screen to display the Bluetooth connection screen; when the call is not answered, short press it to answer the call.

NOTE

- Obey the traffic regulations and use the horn properly.

STEERING WHEEL ADJUSTMENT

ADJUSTMENT METHOD:

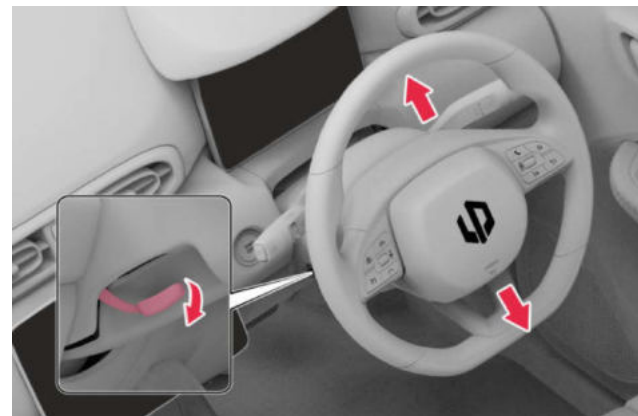

Before driving the vehicle, adjust the steering wheel position according to your own needs.

1. Push the steering wheel adjustment handle downward to adjust the steering wheel up and down until it reaches the desired position, then push the steering wheel adjustment handle upward to lock the steering wheel.
2. Move the steering wheel up and down to make sure it is firmly locked.

WARNING

- Do not adjust the steering wheel while the vehicle is driving to avoid traffic incidents.

Riding

- After adjusting the steering wheel, make sure the steering wheel is locked firmly. Otherwise, the steering wheel may move suddenly, causing an accident that could result in serious injury or death.

STEERING MODE

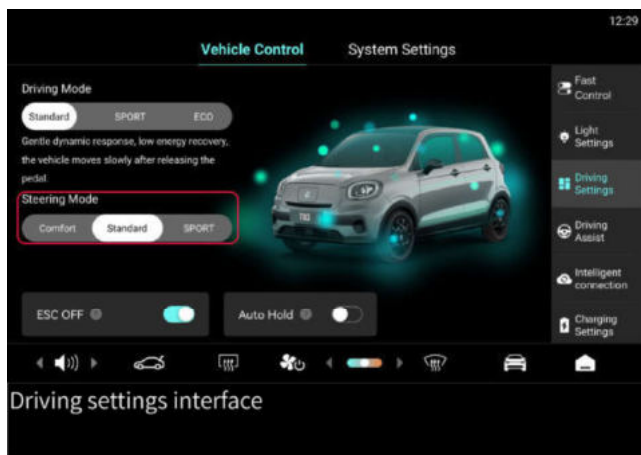

The steering modes can be set in the Vehicle Control - Driving Setup in the Infotainment Screen:

- **Comfort:** In this mode, the steering power increases and the steering feels light and nimble.
- **Standard:** In this mode, the steering power is moderate and the steering feel is moderate.
- **Sport:** In this mode, the steering power decreases and the steering feels composed.

RIDING ON FRONT PASSENGER'S SIDE

FRONT PASSENGER'S SEAT ADJUSTMENT

4-WAY ADJUSTABLE FRONT PASSENGER'S SEAT



Adjusting the front passenger's seat forward/backward: Pull up the adjusting lever, then gently lean against the seat, slide the seat to the desired position, and release the lever.

⚠ WARNING

- Be careful when adjusting the seat to ensure that it does not hurt other occupants when it moves.
- Don't place your fingers or other body parts under the seat, or you may get hurt by the seat.

📌 NOTE

- Do not place items under the seat, as this may hinder the operation of the seat.
- After the front and rear positions are adjusted, slide the seat back and forth to make sure the seat is locked.

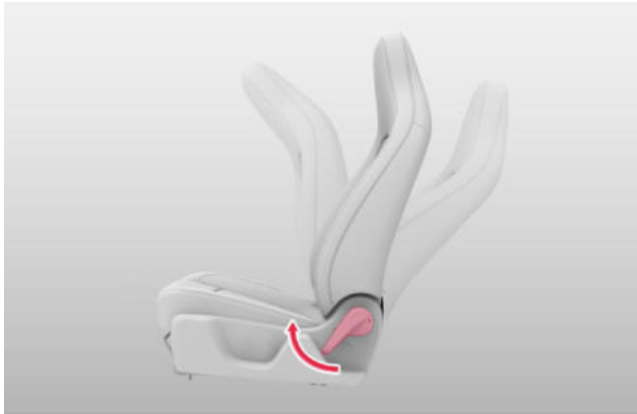

Adjusting the front passenger's seat backrest: Pull the lever up, use your back pressure to tilt the backrest forward or backward, adjust the backrest to the desired position, and release the lever.

⚠ WARNING

- When adjusting the tilt angle of the backrest, ensure your back is tightly against the backrest to prevent the backrest angle from changing too fast, which may cause unnecessary injuries.
- Don't adjust the seat during driving to avoid losing control of the vehicle due to seat movement.
- Don't adjust the seat while the seat belt is buckled up to prevent the seat belt from leaving the normal use condition,

leading to injuries to the occupant and failure of the protective function.

- Do not modify or disassemble the front seats by yourself.
- Wear your seat belt correctly when driving. Improper sitting posture may lead to serious consequences.
- Do not place foot pads or other articles (such as beverage bottles, charcoal bags, etc.) with a thickness exceeding 10mm at the bottom of the front seats, which may be sandwiched between the seat and the slider, hindering the adjustment and locking of the seats, thus damaging the seats. It is recommended to use officially certified foot pads and other products of Leapmotor.

📌 NOTE

- After adjusting the seat, push the seat and seat backrest forward and backward to make sure the seat and seat backrest are locked.
- When the depth of the driver's seat cushion is measured in the factory, the seat is located 10mm forward of the last position of the slider range (the maximum adjustment range of the front and rear positions is 210mm), and the design angle of the backrest is 22° (with a forward tilt of 17° and a castor of 49°).

WINDOW CONTROL

WINDOW CONTROL

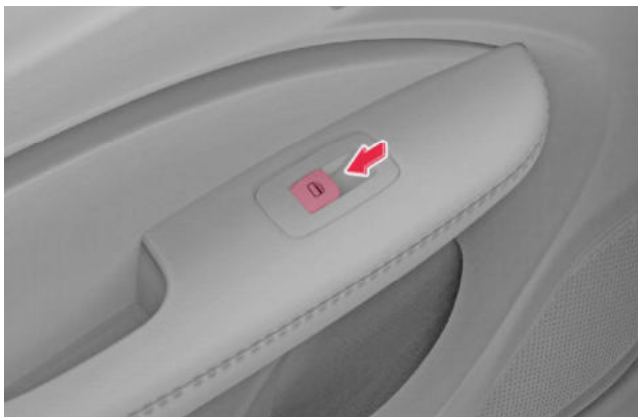

When the vehicle is powered on, use the front passenger's power window control switch to control the corresponding side window glass to raise and lower.

Manual window lifting: Gently pull up (in hold state) the window control switch to raise the window. After the switch is released, the window stops movement.

Manual window lowering: Gently press (in hold state) the window control switch to lower the window. After the switch is released, the window stops movement.

Automatic window lifting: Pull up the window control switch to its limit position and then release it, and the window will automatically rise to its limit position.

Automatic window lowering: When the vehicle is powered on, you press the window control switch to its limit position and release it, and then the window will lower to its limit position automatically.

NOTE

- In the process of automatic descending, pull up or press the control switch to any position to stop the automatic descending movement of the window.
- For the anti-pinch function, manual calibrating and thermal protection function of the front passenger's window, refer to the section of [Window control](#) (page 64).

RIDING IN REAR SEATS

REAR SEAT HEADREST ADJUSTMENT

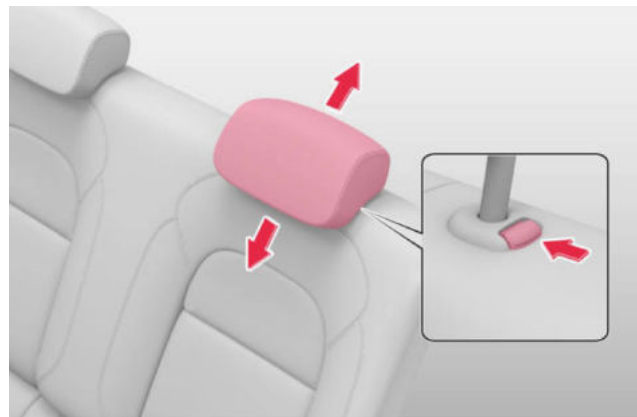

Up: Pull the headrest upwards to the desired position.

Down: Press the headrest lock release button while pushing the headrest downwards to the desired position, and then release the lock release button.

Remove: Press the headrest lock release button and lift the headrest upwards to remove it.

Mount: Align the headrest with the installation hole and push it downwards until it locks into place. Press the headrest lock release button and adjust the headrest downwards.

⚠ WARNING

- Do not adjust, remove, or mount the headrest while driving.
- Please use original headrests provided by the factory.
- Always adjust the headrest to the desired position.
- After adjusting the headrest, press it downwards to ensure it is securely locked.

📌 NOTE

- For folding the rear seat, please refer to the [Folding of rear seat back](#) (page 41).

WINDOW CONTROL

For the rear occupant side window control, refer to the [Window control](#) (page 72) section.

📌 NOTE

- For the anti-pinch function, manual calibrating and thermal protection function of the rear passenger side windows, refer to the section [Window control](#) (page 64).

REAR STORAGE

DOOR INTERIOR TRIM PANEL STORAGE COMPARTMENT



The storage compartment on the interior trim panel of the door can be used to store beverage bottles or other small items.

📌 NOTE

- Don't place heat-sensitive substances such as chocolate or medicines in the storage compartment on the interior trim panel of the door.
- It is forbidden to place flammable, explosive and splashing articles in the storage groove.
- Do not put glasses, lighters or spray cans in the storage groove to avoid damage caused by bumps.

COMFORTABLE RIDING

A/C

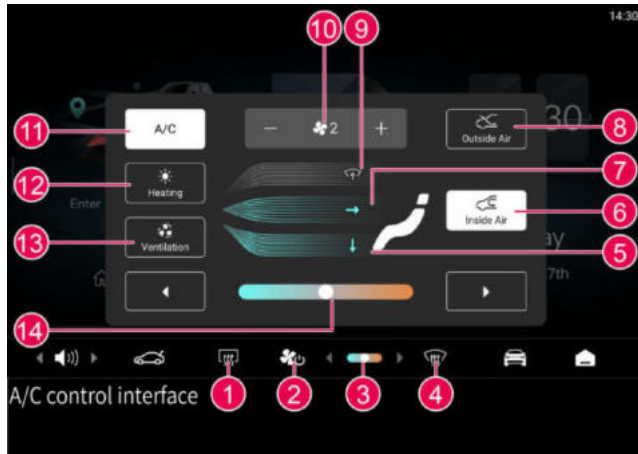

1. Rear windshield defroster switch: When it is lit, the rear windshield defroster function is turned on, and turned off automatically after 20min.
2. Blower switch: When it is lit, turn on the blower, display the A/C control screen, and at the same time restore to the state of the A/C set for the previous driving cycle. Touch it again to turn off the blower.
3. A/C temperature indicator bar: Tap to display the A/C control screen, and slide the temperature control slider in the A/C control screen to adjust the A/C temperature.
4. Front defroster switch: When it is lit, the front windshield defroster/defogger is turned on, the air volume is in level 3; touch it a second time to increase the air volume to level 5, and

then touch it again to turn off the front windshield defroster/defogger.

5. Feet-blowing mode: When it is on, enable the feet-blowing mode.
6. Inside air mode: When illuminated, the inside air mode is activated.
7. Face blowing mode: When illuminated, the face blowing mode is activated. Face blowing mode and foot blowing mode can be turned on at the same time.
8. Outside air mode: When illuminated, the outside air mode is activated.
9. Windshield blowing mode: When illuminated, the front windshield blowing mode is activated. Windshield blowing mode and face blowing mode cannot be turned on at the same time.
10. Air volume adjustment: Tap "+" or "-" to adjust the blower air volume, with the air volume adjustment range of 1-7 levels.
11. Cooling switch: When it is lit, the A/C compressor works and the A/C enters the cooling mode.
12. Heating switch: When it is lit, the A/C PTC is powered for heating and the A/C enters the heating mode.
13. Ventilation switch: When it is lit, the A/C blows natural air and enters the ventilation mode.
14. Temperature setting bar: Slide the slider or tap the arrows on the left and right to adjust the A/C temperature,

⚠ WARNING

- Prolonged use of the inside air mode in cold or rainy weather can cause mist on windows, which will impair driving visibility and may lead to major incidents.

OPERATION ESSENTIALS

- If the vehicle is in a high-temperature environment for a long time, it is recommended to open the doors and then open the A/C, adjust the air volume to the highest gear, and then close

the doors after the temperature inside the vehicle is reduced. Adjust the temperature inside the vehicle as needed.

- It is recommended to close all windows when tailgating other vehicles on dusty roads or when driving in windy and dusty conditions. If the dust raised by the vehicle still enters the vehicle after the windows are closed, it is recommended to switch to Inside Air.

FUNCTIONAL DESCRIPTION

Cooling and heating:

1. When the vehicle is powered on, touch  in the Infotainment Screen to turn on the blower and enter the A/C setting screen.
2. Light up the A/C cooling or heating switch on the A/C setting screen to switch to cooling or heating mode.
3. Adjust the air volume, circulation mode and A/C temperature as needed.

NOTE

- When the vehicle is in a high temperature environment and needs to cool down quickly, please adjust the temperature to the minimum value in the cooling mode and select the inside air mode to run for a few minutes.
- To protect the A/C compressor, do not switch the A/C on and off frequently.
- The inside air mode can be selected appropriately, which can speed up the efficiency of cooling or heating and help improve the economy and comfort of the vehicle.
- Make sure the air intake grille in front of the windshield is not blocked (such as by leaves or snow).

Front windshield defroster/defogger:

1. When the vehicle is powered on, touch  in the Infotainment Screen to turn on the front windshield defroster/defogger, with



the air volume in level 3; touch it a second time to increase the air volume to level 5.

2. With the front windshield back in clear view and the air volume in level 5, touch  on the Infotainment Screen again to turn off the front defroster/defogger.

NOTE

- When the front windshield defroster/defogger is turned on, the side mirror heating function is turned on simultaneously, and the heating time can last for a maximum of 30min at a single time.
- Do not place anything on the instrument panel to avoid covering the air outlet and affecting the defogging of the windshield.

Rear windshield defroster/defogger:

1. When the vehicle is powered on, touch  in the Infotainment Screen to turn on the rear windshield defroster/defogger.
2. With the rear windshield back in clear view, touch  again to turn off the rear defroster/defogger. If you do not manually turn off the rear windshield defroster/defogger, the function will automatically turn off after 20min of continuous operation.

ATTENTION

- After the rear windshield defroster/defogger is turned on, the rear windshield glass will become hot, and it is forbidden to touch it for burns.
- When cleaning the inside of the rear windshield, be careful not to scratch or damage the electric heater wire or connectors.

A/C OFF:

Touch  in the Infotainment Screen to turn off the A/C system.

⚠ WARNING

- Do not rest in the vehicle for a long time to avoid dyspnea or suffocation when the window is closed or poorly ventilated.

ⓘ ATTENTION

- If the cooling effect of the A/C system is not good, please promptly contact the authorized dealer.
- The refrigerant can be recycled. Do not discharge the refrigerant directly into the atmosphere to avoid polluting the environment.

📌 NOTE

- When the A/C is just turned on, the air from the A/C may have a damp and moldy odor, which is a normal phenomenon. During the use of vehicle A/C, the evaporator is easy to attach A/C condensate, and the wet evaporator is also easy to absorb unfiltered sweat, smoke, etc. If the condensate on the evaporator cannot be blown dry, the dark and wet evaporator surface is easy to breed mold, and mold fermentation for a long time is easy to produce odor.
- To prevent A/C odor, please turn off the cold air before parking, ventilate natural air for 3-5 min to keep A/C relatively dry, and check, clean or replace the filter regularly.
- If the odor cannot be eliminated, please promptly contact the authorized dealer.

AIR OUTLET POSITION

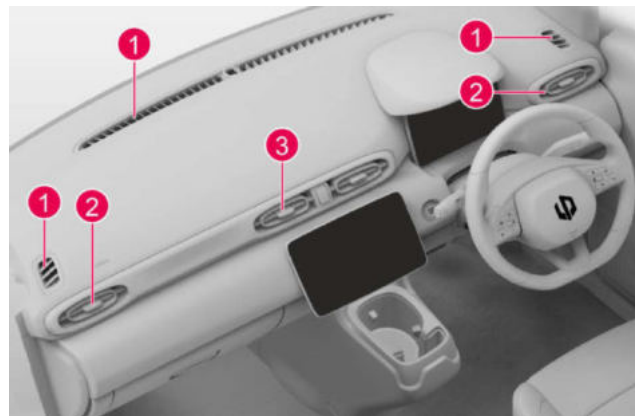

1. Defrost vent
2. Side vent
3. Central vent

VENT ADJUSTMENT

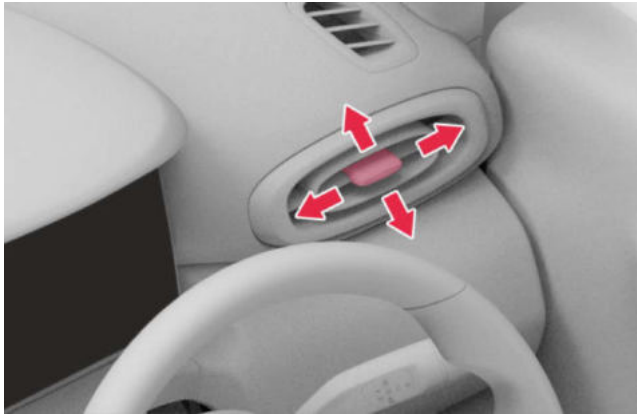

Turn the vent fork up and down, left and right to adjust the airflow direction of the vent.

SUNROOF SHADE CONTROL*

SUNROOF SUNSHADE CONTROL BY SWITCH

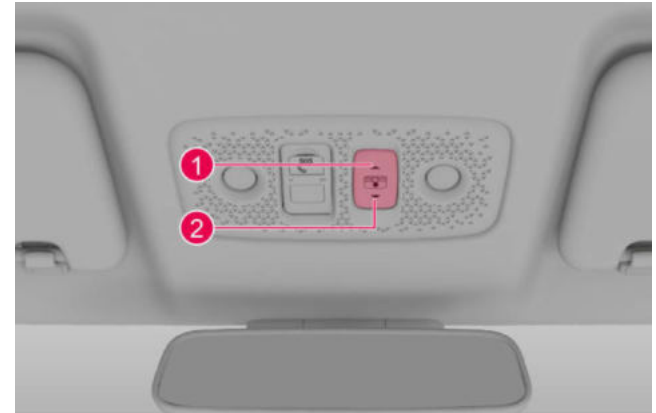

1. Sunroof shade opening button
2. Sunroof shade closing button

Open the sunroof shade

Auto Open: When the vehicle is powered on, as you short press the sunroof shade opening button, the sunshade will open automatically to the fully open position, and during the sunshade opening operation, as you press the sunshade opening or closing button, the sunshade will stop operation.

Manually Open: When the vehicle is powered on, press and hold the sunshade opening button to open the sunshade, and release the button to immediately stop the sunshade opening action.

Close the sunroof shade

Auto Close: When the vehicle is powered on, as you short press the sunshade closing button, the sunshade will close automatically to the fully closed position, and during the sunshade closing operation, as you press the sunshade opening or closing button, the sunshade will stop operation.

Manually Close: When the vehicle is powered on, press and hold the sunshade opening button to close the sunshade, and release the button to immediately stop the sunshade closing action.

SUNROOF SUNSHADE CONTROL BY INFOTAINMENT SCREEN

When the vehicle is powered on, control the sunshade opening status by sliding the sunshade control bar in the Vehicle Control - Quick Control interface on the Infotainment Screen.

⚠ WARNING

- When closing the sunshade, take care to avoid the occupant's body parts being caught in the closing sunshade, thus causing serious injury.
- Do not allow children to operate the sunshade to avoid being pinched.

📌 NOTE

- If the sunroof shade cannot be tightly closed or cannot be closed at all with the normal operation method after it is used for several times, initialize the sunroof shade manually. For details, refer to the section of [Initialization of sunroof shade *](#) (page 210).

FRONT STORAGE

DOOR INTERIOR TRIM PANEL STORAGE COMPARTMENT



The storage compartment on the interior trim panel of the door can be used to store beverage bottles or other small items.

📌 NOTE

- Don't place heat-sensitive substances such as chocolate or medicines in the storage compartment on the interior trim panel of the door.
- It is forbidden to place flammable, explosive and splashing articles in the storage box.
- Do not put glasses, lighters or spray cans in the storage box to avoid damage caused by bumps.

CENTRAL STORAGE BOX



The central storage box can hold cell phones, cards or other small items.

INSTRUMENT PANEL STORAGE BOX

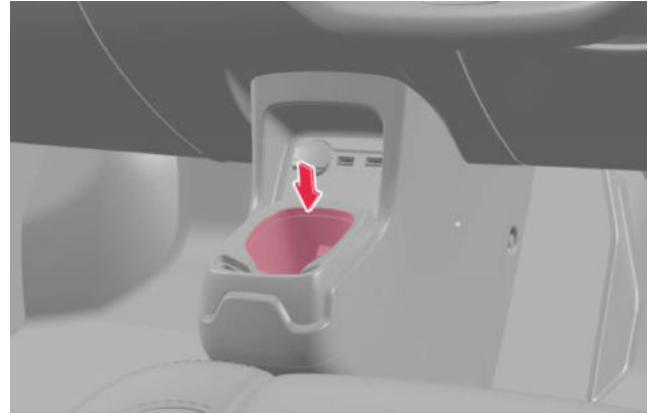

The instrument panel storage box can hold other small items such as keys.

⚠ WARNING

- Do not place sharp objects in the storage boxes to prevent them from being thrown out during an incident or emergency braking and injuring the driver or passengers.

CUP HOLDER

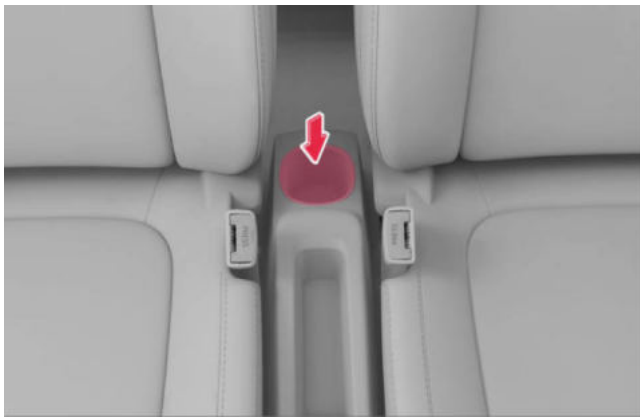

Cups or drinks can be placed in the cup holder.

⚠ WARNING

- Do not use fragile cups, which will cause secondary damage in the event of an incident.
- Make sure the lid of the cup or beverage can is properly closed to prevent liquid from spilling during driving.

📌 NOTE

- Do not place anything other than cup or beverage can in the cup holder, which may cause items to fall or damage the cup holder.

GLOVE BOX



Open the glove box by pulling the glove box catch.

Push the glove box upward to close it.

⚠ WARNING

- To reduce the possibility of injury in the event of an incident or emergency braking, the glove box must be kept closed while driving.
- Do not pull the open glove box hard to avoid damaging the glove box or hurting yourself.

ASSIST GRIP

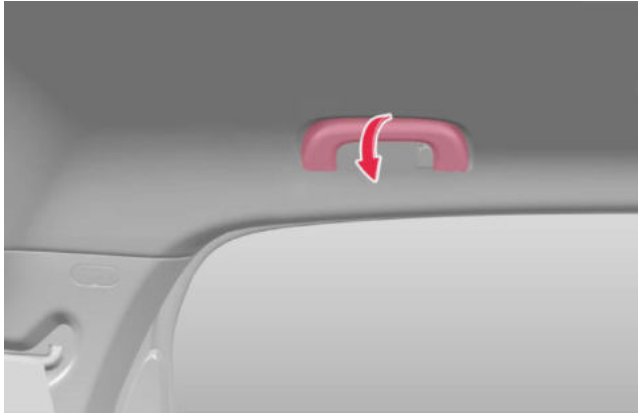

The assist grips are located above the rear windows. During driving, rear passengers can use the assist grips to maintain balance.

ⓘ ATTENTION

- Do not hang items on the assist grips to avoid damage caused by excessive weight.
- Do not pull or drag the assist grips when getting on or off the vehicle or when getting up from the seat.

SUN VISOR

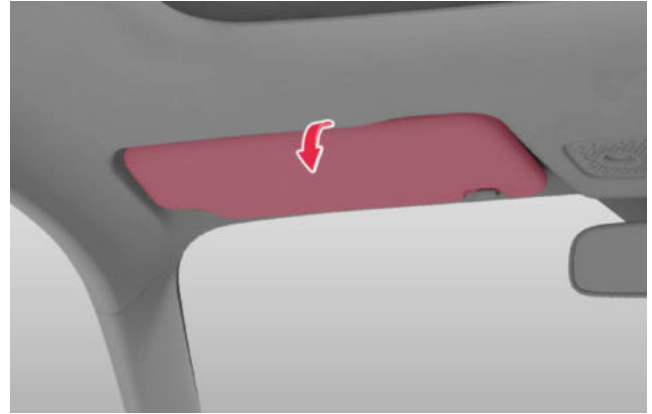

The sun visor is located above the driver's and front passenger's side. To block the glare from the front of the vehicle, flip the sun visor down.



To block the dazzling light from the side, remove the sun visor from the inner fixed support and turn the sun visor towards the side window.

WARNING

- Please be sure to adjust the sun visor while ensuring driving safety.

VANITY MIRROR

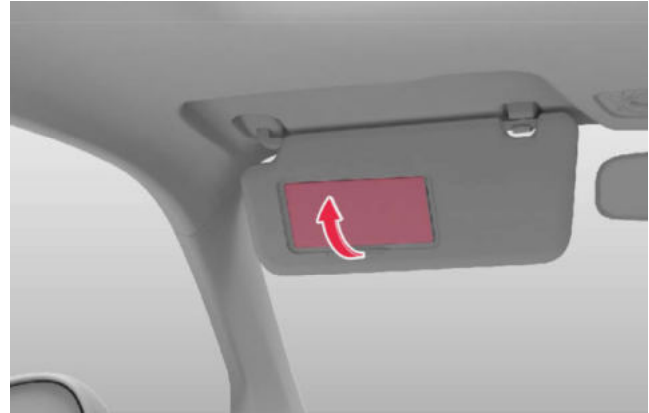

The vanity mirrors are located in the driver's and front passenger's sun visors. After opening the sun visor downward, lift the vanity mirror cover plate upward to expose it.

WARNING

- The driver should not use the vanity mirror during driving for driving safety.

ONBOARD POWER SUPPLY

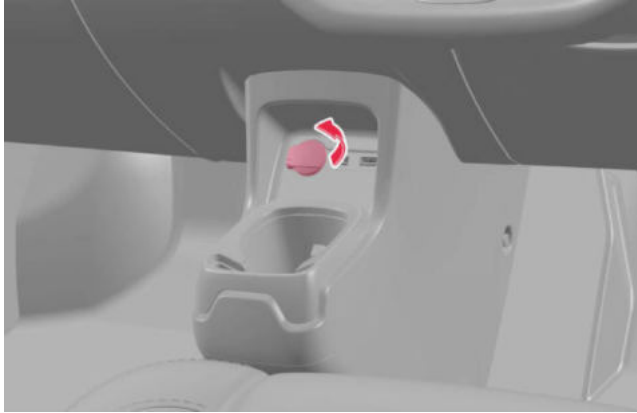

When the vehicle is powered on, open the onboard power supply cover plate and connect the electric equipment to use.

Operating voltage: 12V; Maximum current: 10A.

⚠ WARNING

- Do not use the onboard power supply when nobody is in the vehicle. Improper use may cause fire.
- Do not allow children to operate it.
- Do not use high-power electrical equipment.

ⓘ ATTENTION

- To avoid damage to the vehicle's electrical system, do not connect the power generation equipment to the onboard power supply outlet.
- When turning on or off the vehicle power supply, disconnect the electrical equipment connected to the onboard power supply outlet to avoid damaging the electrical equipment due to voltage fluctuation.

USB PORT

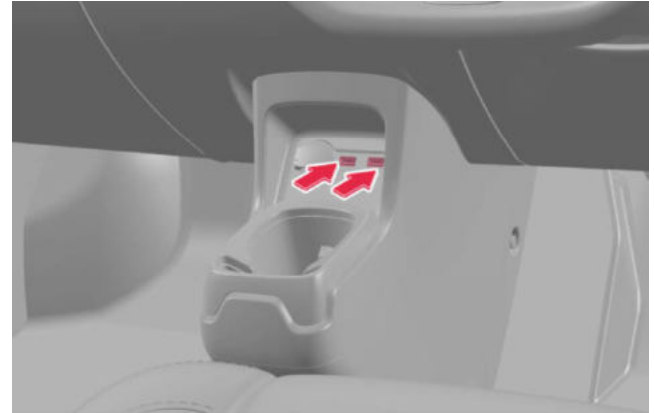

The vehicle is equipped with 2 USB ports, with the left port for charging and data transfer, and the right port for charging only.

USB operating voltage: 5V; Current: 500mA.

IVI SYSTEM

IVI SYSTEM

HOME INTERFACE

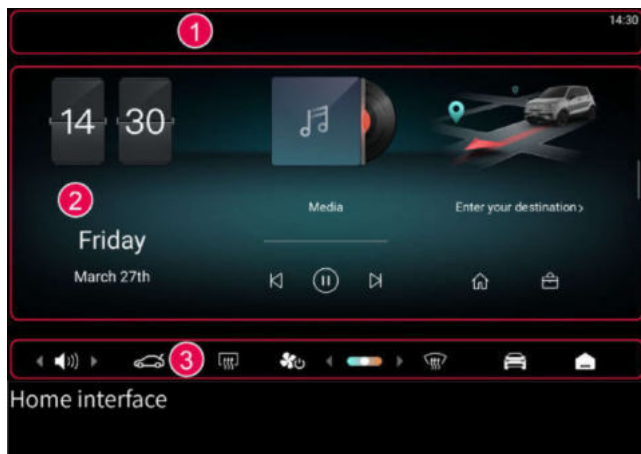

1. Status bar: This area displays the time, Bluetooth and other information.
2. Display window: This area displays information such as navigation, media, calendar, etc.
3. Shortcut bar: The shortcut bar includes Home, vehicle control, A/C shortcut setting, rear trunk opening shortcut key, and volume adjustment.

⚠ WARNING

- For your driving safety, please do not use the IVI system during driving.

1 ATTENTION

- In view of potential online upgrades in the future, the IVI system interface is for reference only. Please refer to the actual vehicle configuration for details.

SIDE SLIDER

Slide the screen from the leftmost end of the Infotainment Screen to the right and pull out the side slider.

The side slider is a shortcut function area where you can touch to open or set the navigation, driving mode, unlock the charger, and adjust screen brightness.

RIGHT SCREEN

Swipe right on the main interface to open the right screen interface. The interface includes applications such as Map, Amazon Music, Phone, DAB+, local media, etc. depending on the actual contents displayed on your vehicle.

GESTURES AND RESPONSES

Tap: To open an application and select a function, just press a button on the screen, or use the on-screen keyboard to enter characters, simply touch with your finger.

Swipe: This operation is allowed in the main interface or application interfaces.

ON: Tap the button in the setting interface, and when the button changes from gray to white, it indicates that the function is enabled.

NOTE

- The IVI system is an Android system, and gestures and responses are the general operations of the Android system.

VEHICLE CONTROL

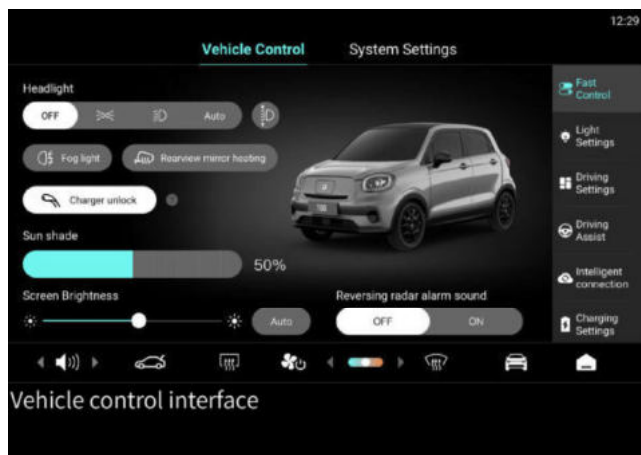

You can control the vehicle lamps, driving mode, driving assist and other related functions through the Vehicle Control in the Infotainment Screen to meet your needs for comfortable driving.

QUICK CONTROL

In the Quick Control interface, you can control the exterior lamps, rearview mirror heating, charger unlocking, sunroof shade control*, and adjust screen brightness, turn on or off the reversing radar alarm.

LAMP SETTINGS

In the Lighting Settings interface, you can touch to set the interior/exterior lamps, activate the Guide Me Home, and adjust the headlamp height. Please refer to the section [Lamp switch](#) (page 140) for details.

DRIVING SETTINGS

In the Driving Setup interface, you can tap to select or open/close the following functions:

- Driving mode
- Steering mode
- ESC
- Autohold

ADAS

In the ADAS interface, tap to select or turn on/off the following functions:

- Automatic emergency braking
- Forward Collision Warning (FCW)
- BSD
- Door Opening Warning
- Lane keeping assist
- LDW
- Distraction warning
- Cruise assist system
- ISA

INTELLIGENT INTERCONNECTION

In the Intelligent Interconnection interface, the following functions are available:

- Set or modify the operation password;

Riding

- Allow the APP to unlock/lock via Bluetooth.
- Owner binding authentication.

CHARGING SETUP

The Charging Setup interface displays charging information and status. Slide the slider on the power indicator bar to set the charging limit.

- The limit charging is enabled by default, with an initial setting value of 80%.
- The charging limit is valid for both slow and fast charging.
- After setting the charging limit, there is no need to repeat the setting afterwards.

NOTE

- The charging limit must be higher than the current battery level of the vehicle.

HEALTH

View the vehicle's health status, tire pressure on the health interface. When a vehicle malfunctions, you can tap to view specific information.

TRAVEL

On the Travel interface, you can view detailed information such as the current mileage and driving data since the last charging.

KEY SETTINGS

In the Key Settings interface, you can tap to set the functions of the custom button of the key fob to one-key locating, one-key window lowering, or one-key A/C ON. Complete the settings,

press Custom on the key fob to activate the corresponding function.

MAINTENANCE

In the maintenance interface, functions such as Experience mode, wiper maintenance and restarting the IVI can be operated.

Experience mode: Select it when you need to experience the vehicle statically. When activated, the vehicle cannot be driven. Before activating or deactivating, please ensure the vehicle is in the parking state.

Wiper maintenance: The function is used when replacing wiper blades or repairing wipers. When the function is enabled, the wiper moves to the maintenance position for easy folding and maintenance of the wiper. After enabling the wiper maintenance function, the wiper cannot be used, and it can be used after the wiper maintenance function is closed.

Restart MMI: In case of operation jam or function error of the MMI system, restart it to restore the system to the state when the vehicle is started.

SYSTEM SETTINGS

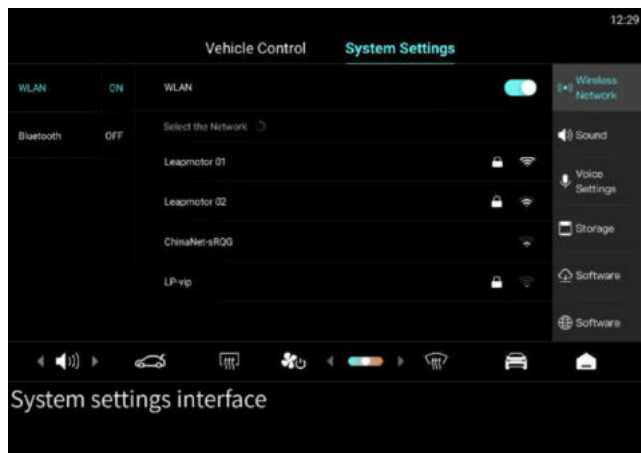

You can set wireless network, sound, storage, general and other related functions through System Settings on the Infotainment Screen to meet your comfortable driving needs.

WIRELESS NETWORK

WLAN and Bluetooth can be turned on or off in the wireless network interface.

SOUND

The following functions can be set in the sound interface:

- Slide the slider to adjust the volume size;
- Open and close the vehicle's mute function when reversing;
- Activate or deactivate the reversing radar alarm;

- Drag and adjust the equalization effect, or reset the equalizer;
- Slide and adjust the sound effect, or reset the sound effect.

VOICE SETTINGS*

In the Voice Settings interface, you can swipe to activate or deactivate the voice wake-up function.

STORAGE

You can view the available space stored by the system in the storage interface.

SOFTWARE

The following operations can be performed on the software interface:

- View vehicle configuration information and VIN;
- View the current version number of the system and upgrade it;
- Restore factory settings.

NOTE

- You need to enter the operation password before restoring factory settings. Please read the prompt information on the Infotainment Screen carefully. The operation of restoring factory settings is irreversible. When you are sure to restore, the MMI system will clear all your information and restore to the default factory settings.

GENERAL

The following operations are available on the General interface:

- Select the system language.
- Set the time display.



Riding

- Select the measuring unit of distance.
- Set privacy permissions and view the privacy policy.

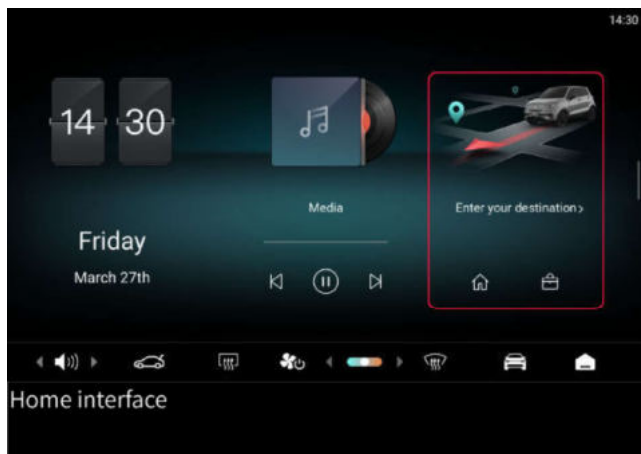
NAVIGATION



Tap the navigation module on the HOME interface or the navigation app on the right screen to enter the navigation interface.

Tap the shortcut icon Home  or Work  in the navigation module to automatically plan a route from the current location to home or work. After selecting and confirming the route, tap Start.

MEDIA

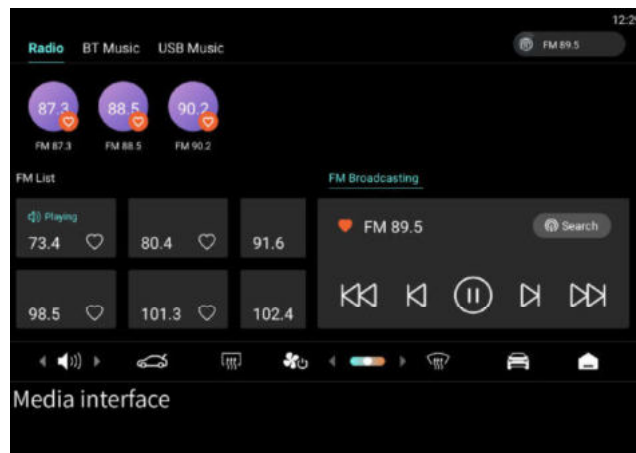

You can switch the media playback source to radio, Bluetooth music, or USB music through the media interface on the Infotainment Screen.

RADIO

In this interface, you can view recommended radio stations, FM broadcasts, and other operations for on-demand broadcasting.

BLUETOOTH MUSIC

You should touch the Bluetooth module on the HOME interface to connect your mobile phone and the vehicle's Bluetooth. After the connection is successful, you can select to play the music in your mobile phone or switch to other mobile phones or devices on this page.

USB MUSIC

In the USB music interface, you can view or play the music stored in the USB flash disk.

The USB flash drive audio formats supported by the Infotainment Screen system are MP3 and FLAC.

PLAY MUSIC

Tap the icons Radio, Bluetooth music and USB music in the IVI system to enter the playback interface.

◀ Previous: Tap it to open the previous audio.

▶ Next: Tap it to open the next audio.

▶ Play: Tap it to play the current audio.

⏸ Pause: Tap it to pause the audio being played.

DAB RADIO

Tap the "DAB+" icon on the right interface of the Infotainment Screen to enter the DAB radio HOME interface.



1. Status bar: It displays time, Bluetooth status, etc.
2. Function button operation area: You can select program types, view program previews, and automatically search for channels.
3. Radio information display area: The radio station logo, name, frequency, program type, etc. are displayed.
4. Radio signal intensity indication
5. Search: Tap it to search for channels in all frequency bands.
6. Favorite: Tap it to view your favorite radio stations.
7. Slideshow: It displays picture information of the radio station in real time.
8. List of radio stations: It displays radio station name, station logo, and favorite station tags.

TEL.



If the vehicle is connected to mobile phone Bluetooth, open the Phone app in the Infotainment Screen. You can select a specific contact person through call records and contact list, and then touch the contact person to make a call.

SPEECH RECOGNITION*

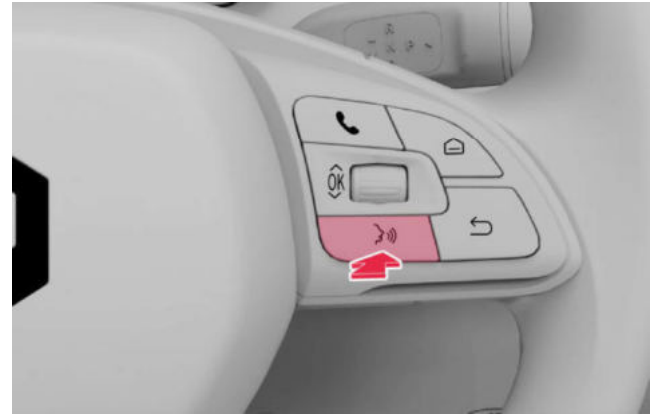

Speech recognition activation:

- Activate speech recognition by pressing the Speech button on the right side of the steering wheel.
- Say "Hi,Leapmotor" in the vehicle to activate speech recognition.

After activating the speech recognition system, the system will respond, and then you can tell it what you want to do, and the vehicle system will respond accordingly.

DRIVING



VIEW THE INSTRUMENT CLUSTER

INSTRUMENT CLUSTER VIEWS



1. Left information display
2. Middle information display
3. Right information display
4. Outdoor temperature display
5. Odometer
6. Time display
7. Battery meter
8. Range
9. Gear display
10. Driving mode display

NOTE

- The instrument cluster page may vary with vehicle configuration differences and later upgrades. Please follow your vehicle prompts.

LEFT INFORMATION DISPLAY

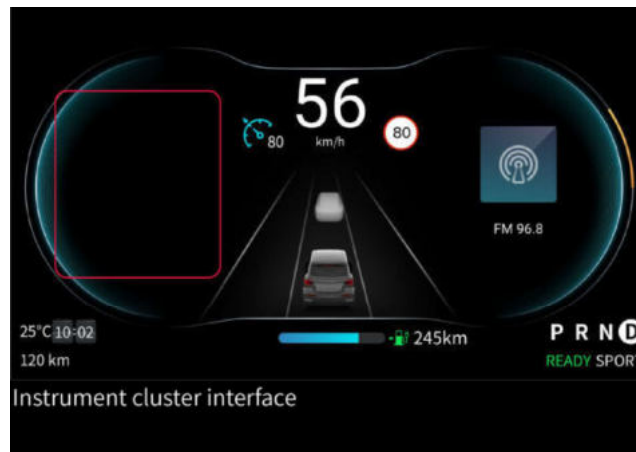

The left information display displays the following information:

- When the vehicle is in the "Reverse" gear, the information display displays the reversing radar information.
- In case of tire pressure alarms, the information display will display the tire pressure alarm information in real time.
- If the above conditions are not met, the information display will not display information.

NOTE

- The left information display displays the priority: Tire pressure alarm > reversing radar information.

MIDDLE INFORMATION DISPLAY

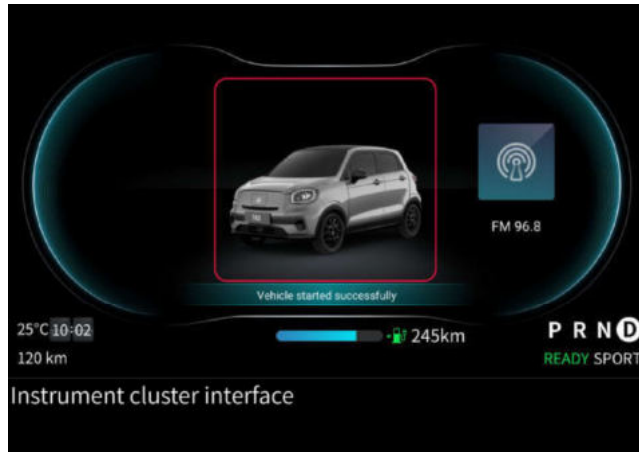

The middle information display displays the following information:

- When parking, the information display displays the status of Leapmotor vehicle.
- When the vehicle is in the "Drive" gear, the information display displays the speed measuring instrument module.

SPEEDOMETER

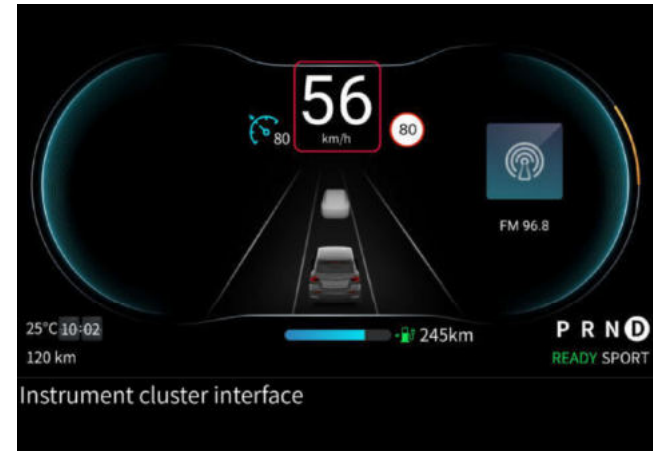

The speedometer displays the current driving speed (km/h) of the vehicle.

! ATTENTION

- To protect the vehicle, it is necessary to avoid driving at the designed maximum speed for a long time.
- Please strictly follow the traffic rules and do not exceed the speed limit.

POWER METER

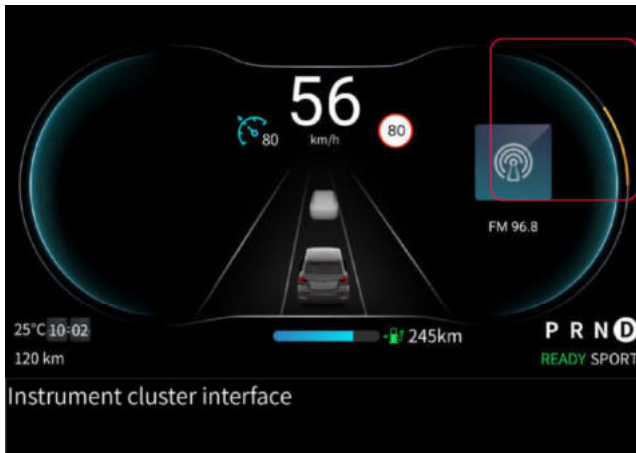

The right-most yellow arc stands for the power meter. The longer the yellow arc, the greater the output power.

RIGHT INFORMATION DISPLAY

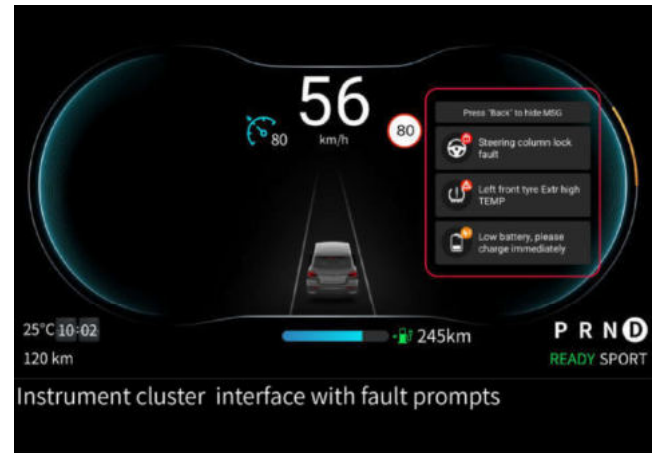

The right information display displays the following information:

- In case of any fault information, the information display will display the instrument fault information.
- When media music is turned on in the Infotainment Screen, the information display displays music information.

FAULT MESSAGES

The fault information is displayed on the right display to remind you of the real-time fault information of the vehicle. You can use the Back button on the right side of the steering wheel to hide the fault prompt in the current driving cycle. When you restart the vehicle, if the fault is not eliminated, the fault prompt will continue to be displayed.

NOTE

- The fault information displayed on the instrument cluster is the real-time fault information of the vehicle. For the sake of your driving safety, please make sure to contact the authorized dealer for troubleshooting as soon as possible.
- The prompt information may vary with vehicle configuration differences and later upgrades. Please follow your vehicle prompts.

BATTERY METER AND RANGE

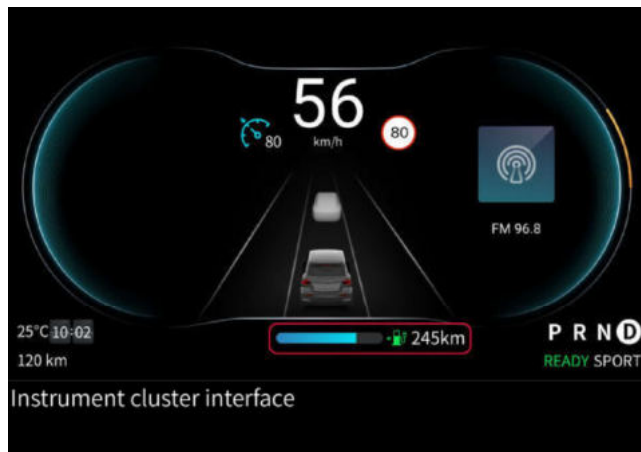

The lower battery bar stands for the battery meter, and the blue color indicates the remaining battery capacity.

The range odometer shows the estimated mileage (km) that the vehicle can continue to drive.

NOTE

- Due to the influence of the service environment, driving habits and other factors, the range of the vehicle may be shortened. Please refer to the actual driving mileage.

FEEDBACK INFORMATION DISPLAY



The feedback information is displayed in the lower part of the middle of the instrument cluster, and used to confirm your current operation or give an error prompt.

NOTE

- The prompt information may vary with vehicle configuration differences and later upgrades. Please follow your vehicle prompts.

INSTRUMENT CLUSTER INDICATOR LAMPS AND WARNING LAMPS



NOTE

• Due to vehicle configuration differences, the display of instrument cluster indicator lamps and warning lamps will be different. please follow your vehicle prompt.

INSTRUMENT CLUSTER INDICATOR LAMPS



Left direction indicator lamp: If the left direction indicator lamp is turned on after the vehicle is powered on, the indicator lamp will flash; if the hazard warning lamp is turned on, the indicator lamp will flash.



Right direction indicator lamp: If the right direction indicator lamp is turned on after the vehicle is powered on, the indicator lamp will flash; if the hazard warning lamp is turned on, the indicator lamp will flash.



Daytime running lamp: If the exterior daytime running lamp is on after the vehicle is powered on, the indicator lamp will be always on.



Position lamp: When the vehicle is powered on and performs self-checks, the indicator lamp is turned off after a few seconds. If the position lamps are on, the indicator lamp will be always on.



Rear fog lamp: When the vehicle is powered on and performs self-checks, the indicator lamp is turned off after a few seconds. If the rear fog lamp is on, the indicator lamp will be always on.



Low beam: When the vehicle is powered on and performs self-checks, the indicator lamp is turned off after a few seconds. If the low beam headlamps are on, the indicator will be always on.



High beam: When the vehicle is powered on and performs self-checks, the indicator lamp is turned off after a few seconds. If the high beam headlamps are on, the indicator lamp will be always on.



Remaining range indicator lamp: It remains on after the vehicle is powered on.



Parking brake indicator lamp: When the parking brake is not released in the power-on state, the indicator lamp is always on.



Battery discharge state indicator lamp: It remains on when the vehicle is powered by the battery. When switching to the power supply of the traction battery, the indicator lamp goes out.



ESC Off indicator lamp: When the ESC is turned off in the Infotainment Screen, the indicator lamp is always on.



READY indicator lamp: The indicator lamp is always on after the vehicle is started; After the vehicle is powered off, the indicator lamp will go out.



AVH indicator lamp: It remains on when Autohold is activated on the Infotainment Screen.



CCS indicator lamp: When the CCS function module is enabled, the indicator lamp is gray; when the CCS function is activated, the indicator lamp is blue.



ACC adaptive cruise control indicator: When the ACC function module is enabled, the indicator is gray; when the ACC function is activated, the indicator is blue.



LDW indicator lamp: It remains on when the LDW system is activated on the Infotainment Screen and functions normally.



LDW off indicator lamp: It remains on when the LDW system is deactivated on the Infotainment Screen.



AEB off indicator lamp: It remains on when the AEB system is deactivated on the Infotainment Screen.



ISA speed limit sign indicator*: It remains on when the ISA system is activated, and a speed limit sign is detected. This indicator will flash 3 times when the vehicle is speeding.



ISA overspeed warning sound off indicator*: It remains on when the overspeed warning sound is disabled on the Infotainment Screen while the ISA system is activated. This indicator will flash 3 times when the vehicle is speeding.



ISA off indicator*: It remains on when the ISA system is deactivated. (This indicator lamp takes precedence over the ISA no reliable speed limit sign indicator lamp).

INSTRUMENT WARNING LAMPS



Light fault warning indicator: If the direction indicator lamp fails after the vehicle is powered on, the warning indicator will always be on.



Traction battery fault warning lamp: If the traction battery has a fault after the vehicle is powered on, the warning lamp will stay on.



Low traction battery SOC warning lamp: It remains on when the vehicle is powered on and the traction battery SOC is too low.



Traction battery overheat warning lamp: It remains on when the vehicle is powered on and the traction battery temperature is too high.



Power limitation indicator lamp: If the power system of the vehicle overheats or has a fault after the vehicle is powered on, the vehicle will drive with reduced power, and the indicator lamp will always be on or flashing.



Insulation fault warning lamp: If the vehicle has insulation fault during the self-check after it is powered on, the warning lamp will stay on.



EPB fault warning indicator: If the EPB fails after the vehicle is powered on, the warning indicator will always be on.



Brake fault warning indicator: When the vehicle is powered on and performs self-checks, the warning indicator is turned off after a few seconds. If the braking system fails, the warning indicator will always be on.



ABS fault warning lamp: If the vehicle is powered on for self-check, the warning lamp will be on for several seconds and then go out. If the ABS has a fault, the warning lamp will stay on.



ESC fault warning indicator: When the vehicle is powered on and performs self-checks, the warning indicator is turned off after a few seconds. If the ESC fails, the warning indicator will always be on.



EPS fault warning lamp: If the EPS has a fault after the vehicle is powered on, the warning lamp will stay on.



Driver seat belt unfastened warning indicator: During vehicle power-on self-check, it illuminates for a few seconds and then goes out. If the driver does not fasten his seat belt, the warning indicator will always be on.



Passenger seat belt unfastened warning indicator: During vehicle POST, it illuminates for a few seconds and then goes out. If the front passenger does not fasten his seat belt, the warning indicator will always be on.



Rear left seatbelt unfastened warning indicator: During vehicle POST, it illuminates for a few seconds and then goes out. If the left rear passenger does not fasten his seat belt, the warning indicator will always be on.



Rear right seatbelt unfastened warning indicator: During vehicle POST, it illuminates for a few seconds and then goes out. If the right rear

passenger does not fasten his seat belt, the warning indicator will always be on.



Airbag fault warning indicator: During vehicle POST, it illuminates for a few seconds and then goes out. If the airbag fails, the warning indicator will always be on.



Door status warning indicator: During vehicle POST, it illuminates for a few seconds and then goes out. If the door is not closed, the warning indicator will be on and the corresponding door opening status will be displayed.



Front and rear trunks state warning indicator: During vehicle POST, it illuminates for a few seconds and then goes out. If the front and rear trunks are not closed, the warning indicator will be on and the corresponding trunk opening status will be displayed.



System fault warning lamp: If the power system has a fault after the vehicle is powered on, the warning lamp will stay on.



Motor overheat warning lamp: It remains on when the vehicle is powered on and the motor temperature is too high.



Motor fault warning lamp: If the motor has a fault after the vehicle is powered on, the warning lamp will stay on.



Tire pressure fault warning indicator: When the vehicle is powered on and performs self-checks, the warning indicator is turned off after a few seconds. If the tire pressure system fails, the warning indicator will always be on.



AVH fault warning indicator: It remains on when the vehicle is powered on and the AVH fails.



ADAS fault warning indicator: It remains on when the ACC, reverse radar system, BSD or DOW fails.



AEB/FCW fault warning indicator: It remains on when the AEB or FCW fails after the vehicle is started.



AEB unavailable warning indicator: It remains on when the AEB system is unavailable (due to weather conditions, deactivated ESC function, etc.) after the vehicle is started.



BSD warning indicator/DOW warning indicator (Left): It remains on when the system detects a vehicle approaching from the left rear after the vehicle is started.



BSD warning indicator/DOW warning indicator (Right): It remains on when the system detects a vehicle approaching from the right rear after the vehicle is started.



DDAW warning indicator*: It remains on when the system detects driver fatigue after the vehicle is started.



ADDW warning indicator*: It remains on when the system detects driver distraction after the vehicle is started.



DDAW/ADDW fault warning indicator*: It remains on when the DDAW system or ADDW system permanently fails after the vehicle is started.



ISA overspeed warning indicator*: It flashes when the system detects the vehicle speed exceeding the speed limit sign during driving.



ISA fault warning indicator*: It remains on when the ISA system fails after the vehicle is started.



LDW/LKA fault warning indicator: It remains on when the vehicle is started and the LDW or LKA system fails.

TIRE PRESSURE MONITORING SYSTEM

The tire pressure monitoring system ("TPMS"), utilizes a highly sensitive micro wireless sensing device fixed in the tires to collect data such as tire pressure while the vehicle is driving or stationary, and displays real-time tire pressure on the Infotainment Screen.

ALARM FUNCTION

The tire pressure fault warning lamp  on the instrument cluster will light up, and the corresponding text warning message will be displayed on the Infotainment Screen when the tire pressure is abnormal or the TPMS is faulty.

When the Infotainment Screen indicate abnormal tire pressure, the vehicle shall be stopped as soon as possible, the tire pressure shall be checked, and the tire shall be inflated to the correct tire pressure range.

When the Infotainment Screen indicate a TPMS fault, it is recommended to contact an authorized dealer for check and repair as soon as possible.

View the vehicle tire pressure information on the Vehicle Control - Health interface on the Infotainment Screen.

See the following table for alarm types and reasons:

Alarm type	Fault cause
Alarm of abnormal high pressure	Tire pressure more than 25% higher than the standard value
Alarm of abnormal low pressure	Tire pressure 25% lower than the standard value
Sensor low battery alarm	Too low battery capacity of sensor
Alarm of rapid tire leakage	The tire pressure drop value of a tire is greater than 30kPa in a short time (within 1 min)

Alarm type	Fault cause
Alarm of abnormal sensor signal	The receiving controller has not calibrated the tire pressure sensor or the sensor is missing

WARNING

- If the tire alarm message is sent during driving, avoid sharp turns and sudden braking. Please reduce the vehicle speed, drive into a safe zone and stop the vehicle as soon as possible. Driving with low tire pressure may cause permanent tire damage and increase the likelihood of tire scrapping. If the tire is severely damaged, it may lead to a traffic accident and cause serious casualties.
- The TPMS regularly transmits tire pressure and other information to the instrument cluster and Infotainment Screen. Therefore, if the tire pressure suddenly drops or bursts during driving, the monitoring module can only transmit the data to the instrument cluster and Infotainment Screen during the next monitoring, which may result in driving out of control. If a tire is damaged and the monitoring module is also damaged and unable to send a message, or if you suspect a tire is damaged, please stop driving immediately and do not wait for the instrument cluster and Infotainment Screen to send an alarm signal before parking.
- If the tire pressure is abnormal, this system will not prevent the vehicle from driving. Therefore, before each driving, the driver should statically start the vehicle to check whether the tire pressure meets the standard tire pressure value. If it does not meet the standard tire pressure value, do not drive the vehicle, otherwise it may damage the vehicle or even cause personal injury or death.

ATTENTION

- The usage time of the TPMS is related to factors such as daily driving distance.
- Improper installation of the TPMS will affect the airtightness of the tire. You are recommended to contact the Leap motor authorized dealer to install and replace the TPMS module by professional technicians.
- To replace wheel rims, exchange tire positions or replace the TPMS module, the entire TPMS should be matched again. It is recommended that the professional technicians from the authorized dealer complete the rematching, otherwise the system may fail.
- As tire pressure varies with regional temperature, please inflate or deflate depending on the tire pressure value displayed on the instrument cluster and the standard tire pressure value as needed.
- As the TPMS transmits data wirelessly, its reception performance may be poor in environments with severe interference.

DRIVE OUT OF PARKING SPACE

START THE VEHICLE

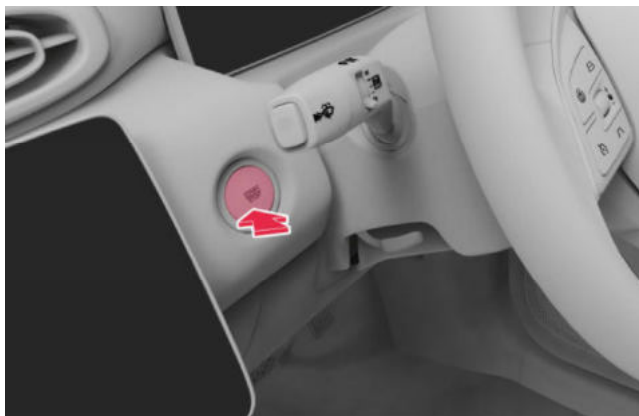

Start the vehicle in the following steps:

1. Unlock the vehicle and open the door to enter the vehicle.
2. Confirm that the gear is in "P" position, that is, parking gear.
3. Press the start/stop button while stepping on the brake pedal (the key fob must be placed in the front row of the vehicle), and the vehicle will be started and in the "READY" state, the instrument cluster will display "the vehicle has started", and the "READY" indicator lamp on the instrument cluster will be on at the same time.

NOTE

- For vehicles equipped with the handheld alcolguard device, the driver must undergo a breath test before starting the vehicle.
- When the vehicle is not powered on, the test result of the alcolguard device will not cause any impact on starting the vehicle.

DRIVING MODE SWITCHING

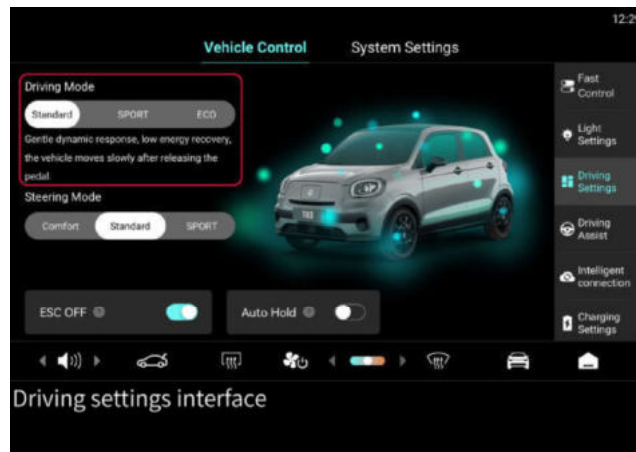

Switch the "Standard", "Sport" and "ECO" driving modes in the Vehicle Control - Driving Modes - Driving mode in the Infotainment Screen.

Standard Mode: The instrument cluster displays "Standard", indicating that the vehicle is in the standard mode, the vehicle power response is gentle, the energy recovery is weak, and the vehicle moves slowly after releasing the pedal.

Sport mode: The instrument cluster displays "Sport", indicating that the vehicle enters sport mode, with faster vehicle power response and moderate energy recovery. After the pedal is released, the vehicle does not slow down.

ECO Mode: The instrument cluster displays "ECO", indicating that the vehicle power response is gentle, the energy recovery is strong, and the vehicle does not slow down after releasing the pedal.

ENERGY RECOVERY

The vehicle is equipped with a brake energy recovery system, which is a function of converting excess energy released during braking or coasting into electrical energy through the motor and storing it back in the traction battery.

During driving, when the accelerator pedal is released, the energy recovery function is enabled, and the vehicle has a significant sense of deceleration. When the accelerator pedal is stepped on again, the energy recovery function is disabled.

GEAR

The shift lever is at the lower part of the right side of the steering wheel. Pull the shift lever up and down to shift gears. At the same time, the instrument cluster displays the current gear.

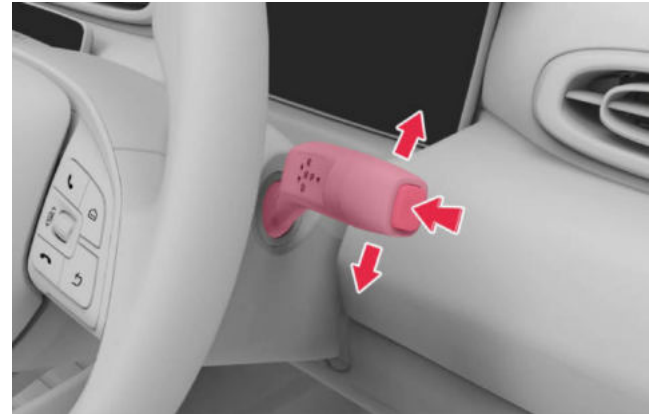

"P" gear (parking): Switch to this gear when parking. Press the "P" button after the brake pedal is stepped on and the vehicle stops completely.

"R" gear (reversing): Switch to this gear when reversing. Before switching to R gear, make sure that the vehicle has stopped completely. When switching from "N" gear to "R" gear, the brake pedal must be stepped on.

"N" gear (neutral): Switch to this gear when the vehicle stops for a short time. When moving from "N" gear to D gear or R gear, step on the brake pedal.

"D" gear (driving): Switch to this gear when driving normally.

WARNING

- After switching gears, it is necessary to confirm the gear position through the instrument cluster. If the gear position

displayed on the instrument cluster does not match the expected one, the gear position should be reconfirmed or a new gear should be switched.

- If switching gears during driving forward, do not step on the accelerator pedal to avoid accidents.

ATTENTION

- Switch to "R" gear only after the vehicle stops completely. Switching to "Reverse" gear when the vehicle is not completely stationary will damage the vehicle.
- In order to avoid damaging the vehicle, please do not coast in "N" gear during driving.
- To stop the vehicle temporarily in "D" or "R" gear, just step on the brake pedal. If you need to get off, you must switch to "P" gear and make sure that the parking braking has been done.
- In case of failure of gear shift, please contact the authorized dealer for maintenance in time.

SPEED CONTROL

PEDALS

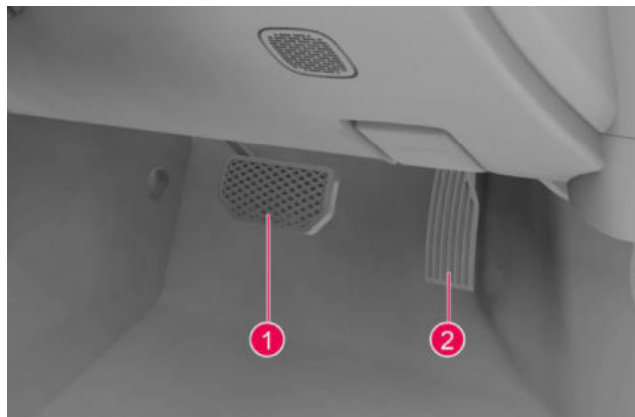

1. Brake pedal
2. Accelerator pedal

WARNING

- Do not store anything in the driver's foot space to prevent it from slipping into the pedal area, which will hinder the driver's operation of the pedals and cause traffic accidents.
- Before driving, make sure that both pedals are stepped on and returned normally.
- The driver must wear suitable shoes that are sensitive to pedal movement.

BRAKE ASSIST SYSTEM

ELECTRONIC STABILITY CONTROL (ESC)

The ESC can effectively reduce the risk of vehicle sideslip.

The ESC determines the driver's driving intention based on the steering wheel angle and vehicle speed, and continuously compares it with the actual driving conditions of the vehicle. If the vehicle deviates from the normal driving route (for example, the vehicle sideslips), the ESC will correct the deviation by applying braking force to the corresponding wheels.

The ESC restores the vehicle to a stable driving state with the torsional force generated by braking.

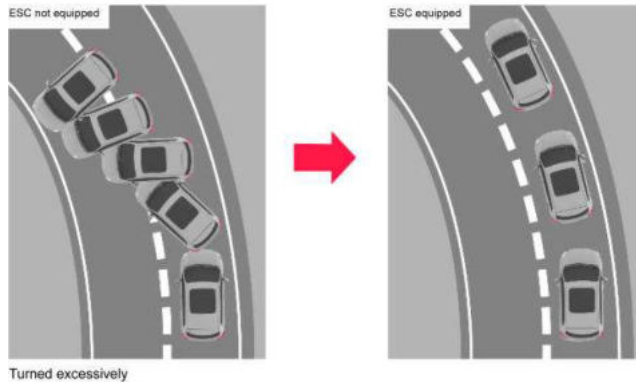

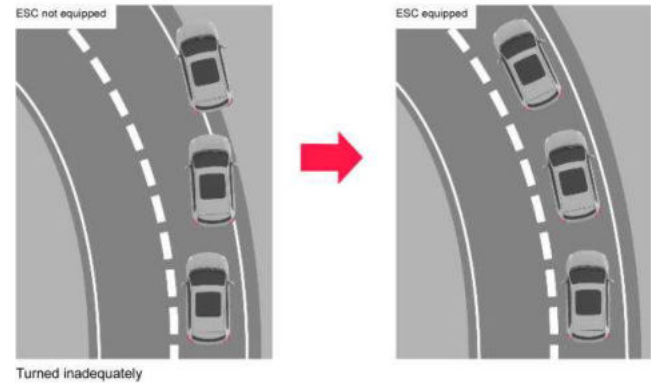

If the vehicle tends to oversteer (i.e. drift), the system will apply braking to the front wheel outside the curve.

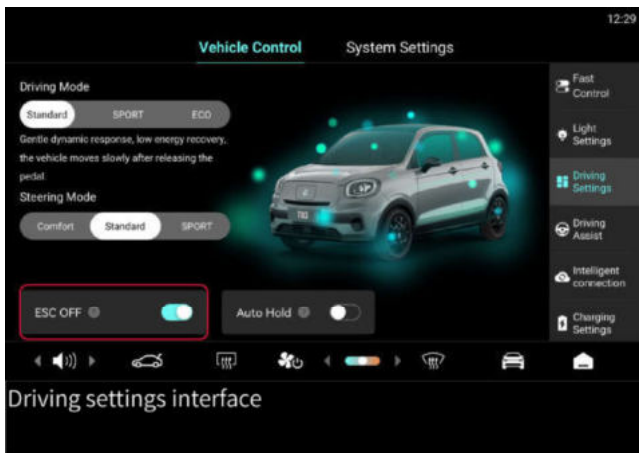

If the vehicle tends to understeer (that is, excessive turning radius), the system will apply braking to the rear wheel inside the curve.

When the vehicle without ESC is driving, it deviates from the normal driving route. When the vehicle with ESC is driving, the braking force can be corrected based on the amount of sideslip to prevent the deviation from the route.



ON and OFF: The ESC is on by default when the vehicle is driving. You can turn off the ESC system by sliding the ESC switch in Vehicle Control - Driving settings in the Infotainment Screen, and the ESC Off indicator lamp  on the instrument cluster will be on.

When the vehicle is running, the ESC should be turned on for driving safety. The ESC function can be deactivated under the following special circumstances:

- The vehicle is driven with anti-skid chains.
- If the vehicle is stuck in deep snow or soft and muddy roads, it should move back and forth.

WARNING

- The ESC is only an assisted system. Do not use the additional safety functions provided by the system to drive at risk. The driver must adjust the speed according to climate, road and traffic conditions and are fully responsible for vehicle safety.
- The ESC cannot exceed the physical limit of road adhesion, and you should be particularly careful when driving on slippery roads or towing.

NOTE

- Improper operation or modification of the vehicle (such as modifications to the braking system or wheel and tire performance) will affect the functionality of the Electronic Stability Control (ESC) system.

ANTI-LOCK BRAKING SYSTEM (ABS)

The anti-lock braking system (ABS) is an active safety device to prevent wheels from locking when braking. When the vehicle brakes, if the front wheels are locked, the vehicle will lose its steering capability. The steering control that must be taken by the driver to avoid obstacles and pedestrians during braking and curve driving cannot be achieved. If the rear wheels are locked, the braking stability of the vehicle will become worse. Under the influence of a small lateral force (such as lateral wind force), the vehicle will drift, even turn around and have other dangerous phenomena. In addition, when the wheels are locked, the local severe friction of the tire will greatly shorten its service life.

Advantages of ABS system:

- Improve the brake efficiency and shorten the braking time and distance.
- Effectively prevent the sideslip and drift of the vehicle during emergency braking, and have good driving stability.

- It can turn in case of emergency braking and has good steering control.
- Avoid the severe friction between the tire and the ground and reduce the wear of the tire.

The ABS consists of an electronic control system to prevent wheel lock and an ordinary braking system. The electronic control system of ABS consists of sensors, controllers and actuators.

The electronic controller of ABS has self-diagnosis and fail safe functions. When the vehicle is powered on, the system performs self-check. If the system is not working properly, the ABS fault warning lamp  on the instrument cluster will stay on, and the words "Please check ABS" will be displayed at the same time, the ABS system will stop working and the normal braking will be restored. It is recommended to go to the authorized dealer for check and repair as soon as possible.

WARNING

- The ABS is only an assisted system. Do not use the additional safety functions provided by the system to drive at risk. The driver must adjust the speed according to climate, road and traffic conditions and are fully responsible for vehicle safety.
- The driver should always maintain a safe distance from the vehicle in front and be aware of the dangerous situations during driving. Although the ABS can improve the braking distance, it cannot go beyond the physical law, nor can it prevent the danger caused by tire slip (such as when there is water layer between the road and the tire to prevent the tire from directly contacting the road).
- When stepping on the brake pedal makes a harsh friction noise during driving, please find a safe area to stop as soon as possible and contact the authorized dealer to avoid traffic accidents or personal injuries caused by brake failure.

ATTENTION

- Improper operation or modification of the vehicle (such as modifications to the braking system or wheel and tire performance) will affect the functionality of the ABS system.
- Tires of the size specified by the manufacturer must be used. If the tire size is incorrect or the size of all tires is inconsistent, the ABS cannot work effectively.

Braking under emergency

If emergency braking is required, the driver should depress the brake pedal with force, even on a slippery road. ABS can ensure that the wheels will not be locked, and will stop the vehicle moving in the shortest distance in most cases.

On soft roads covered with powdery snowflakes, sand, gravel, etc., the braking distance with ABS may be longer than that without ABS, and even the steering force will be increased. This is because the locked wheels on soft roads become wedges ahead, which help stop the vehicle from moving. No matter how hard you step on the brake pedal, you can continue to operate the vehicle in the usual way.

WARNING

- ABS cannot reliably compensate for driver's operational errors or inexperience.

ELECTRIC BRAKE FORCE DISTRIBUTION (EBD)

The EBD is a part of the ABS. When the vehicle is braking normally, the EBD balances the brake force distribution of the front and rear wheels according to the load on the vehicle.

When the vehicle is powered on and the parking brake is released, if the brake fault warning indicator  is always on, the

braking system may be faulty and the EBD may not work. Please stop the vehicle immediately and contact the authorized dealer for maintenance as soon as possible.

WARNING

- Do not continue to drive the vehicle when the brake fault warning lamp is on.
- The EBD is only an assisted system. Do not use the additional safety functions provided by the system to drive at risk. The driver must adjust the speed according to climate, road and traffic conditions and are fully responsible for vehicle safety.

HILL-START ASSIST CONTROL (HLA)

The Hill-start Assist Control (HLA), an active safety system based on the software function expansion of the ESC, is used to help the driver start the vehicle smoothly on a steep slope.

If the vehicle is stationary, the system will detect whether the vehicle is on a slope via the longitudinal acceleration sensor. Then the system will be automatically in the working state when the vehicle starts from a stationary state on a slope (forward or reverse uphill). At the time of starting, if the driver releases the brake pedal, the system will maintain the previous braking force to ensure that the vehicle still stops.

For starting on a slope, the system will prevent the vehicle from sliding backward when the brake pedal is released and the accelerator pedal is stepped on to improve the safety and reliability of the vehicle starting on a slope.

HHC will be activated if the following conditions are met simultaneously:

- The vehicle is parked stably on an uphill road with a gradient of over 3% for more than 2s.

- The Electronic Stability Control (ESC) is fault-free.
- Electronic parking brake (EPB) is free of fault and released.
- In the forward or reverse gear.
- Apply sufficient force to the brake pedal.

If the driver releases the brake pedal on an uphill road, HHC will keep the vehicle stationary for about 1~2s. If the vehicle is not started within 1~2s, the brake will be released automatically and the vehicle will slide. At this time, the driver should depress the brake pedal immediately.

WARNING

- It is impossible for the HLA to keep the vehicle at a standstill on a slope under any circumstances (for example, the ground is slippery; there is ice and snow or plateau), and it is also impossible to replace the driver's attention to driving.
- The HLA is only an assisted system. Do not use the additional safety functions provided by the system to drive at risk. The driver must adjust the speed according to climate, road and traffic conditions and are fully responsible for vehicle safety.
- When the HLA system is working, the driver is strictly prohibited from leaving the vehicle, otherwise serious safety incidents may occur.
- Do not abuse the HLA as a parking brake. This system is only used as a starting aid in driving.
- When traveling and stopping on the uphill section with heavy traffic, in order to prevent the vehicle from rolling, please firmly step on the brake pedal for a few seconds before starting.
- The HLA can only prevent the vehicle from sliding for a short period of time. The driver should drive cautiously to avoid the vehicle from sliding due to prolonged time.

HYDRAULIC BRAKE ASSIST (HBA)

The Hydraulic Brake Assist (HBA) is an active safety device. When the driver quickly steps on the brake pedal to the limit position, HBA recognizes that the vehicle is in an emergency state and quickly increases the brake pressure to the maximum value, thus enabling the ABS to intervene more quickly and effectively shorten the braking distance.

WARNING

- The HBA is only an assisted system. Do not use the additional safety functions provided by the system to drive at risk. The driver must adjust the speed according to climate, road and traffic conditions and are fully responsible for vehicle safety.
- The HBA can improve driving safety, but it cannot eliminate the dangers caused by following too closely, vehicle slipping, speeding and fast turning. Please drive with caution.

TRACTION CONTROL SYSTEM (TCS)

The traction control system (TCS) is an anti-skid control system that determines whether the driving wheel slips by the number of revolutions of the driving wheel and the number of revolutions of the driven wheel, and suppresses the speed of the driving wheel when the former is greater than the latter. When the vehicle brakes on a smooth road, the wheels will slip and even lose control of direction. When the vehicle starts or accelerates rapidly, the driving wheel may also slip, and there is also a risk of losing control of direction on smooth roads such as ice and snow. The function of the TCS is to automatically control the driving force when the vehicle accelerates to keep the slippage of tires within a reasonable range and maintain the stability of the vehicle.

WARNING

- The TCS is only an assisted system. Do not use the additional safety functions provided by the system to drive at risk. The driver must adjust the speed according to climate, road and traffic conditions and are fully responsible for vehicle safety.

BRAKE OVERRIDE SYSTEM (BOS)

When the driver steps on the brake pedal, even if the accelerator pedal is also stepped on, the Brake Override System (BOS) will prioritize the execution of the braking signal. The driver can still achieve braking and stopping by stepping on the brake pedal.

WARNING

- The BOS is only an assisted system. Do not use the additional safety functions provided by the system to drive at risk. Drivers must drive with caution and take full responsibility for the safety of the vehicle.

PEDESTRIAN WARNING SYSTEM

The pedestrian warning system is equipped to make other participants on the road, including pedestrians and non-motor vehicles, especially the blind and visually impaired persons, more easily detect the approaching of vehicles to avoid incidents.

When the vehicle is in "READY" state and in "Drive" gear:

- 0 < vehicle speed \leq 30km/h, the pedestrian warning system gives forward warning sounds that vary with the vehicle speed.
- If the vehicle accelerates and the speed is greater than 30km/h, the pedestrian warning system will stop sounding.
- The vehicle accelerates, and then decelerates when the speed is greater than 30km/h; 0 < vehicle speed \leq 30km/h, the pedestrian warning system will emit a forward warning tone as the speed changes.

If the vehicle is in "Reverse" gear and the vehicle speed is greater than 0, the pedestrian warning system will emit a reversing warning tone.

⚠ WARNING

- The pedestrian warning system is only an assisted system and cannot actively control the vehicle to avoid incidents. The driver should always observe the road conditions and drive carefully.

📌 NOTE

- If the vehicle is in "Neutral"/"Park" gear, the pedestrian warning system will stop sounding.

AUTOHOLD

When the motor is running and the vehicle needs to stop frequently or for a long time (such as waiting in front of traffic lights, stopping on a slope or following the traffic flow), the AVH can help the driver park the vehicle steadily and automatically prevent the vehicle from moving without depressing and holding the brake pedal all the time. When the driver steps on the accelerator pedal and starts driving, the AUTOHOLD immediately releases the brake, and the vehicle starts to move along the road gradient.

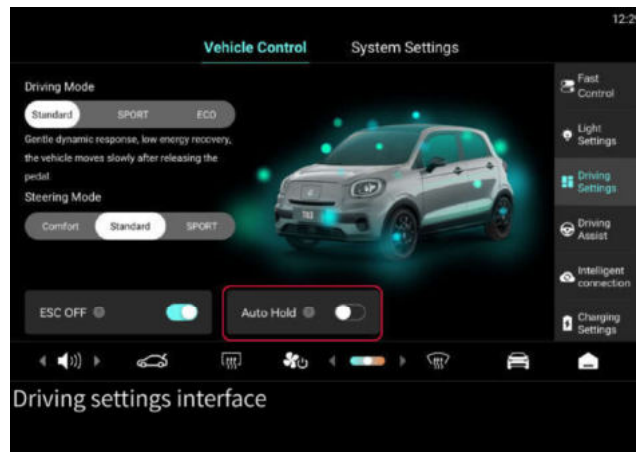

Turn on or off: You can turn on or off the AUTOHOLD function by sliding the "Autohold" switch in the Vehicle Control - Driving Settings in the Infotainment Screen.

The AUTOHOLD function will be off and the EPB will not be locked under the following conditions:

- Stepping on the accelerator pedal when starting.
- Press the EPB switch while stepping on the brake pedal.

To ensure safety, the activated Autohold function will be turned off and the EPB will be locked in case of one or more of the following cases:

- Power off the vehicle.
- Open the driver's door in the parking state.
- The brake pedal is not stepped on and the "Autohold" function in the Infotainment Screen is turned off.

⚠ WARNING

- After the Autohold keeps the vehicle stop stably, if you switch to electronic parking for some reasons (such as unfastening the seat belt or turning off the Autohold switch), it is not guaranteed that the vehicle can be stable under all circumstances. Please ensure that the vehicle has stopped stably before leaving the vehicle.
- Do not take advantage of the additional convenience function provided by the Autohold to drive at risk, otherwise accidents may occur. The driver must adjust the speed according to climate, road and traffic conditions and are fully responsible for vehicle safety.
- When the vehicle starts on a mountain road or on a downhill road (for example, when the road is wet or icy), the AUTOHOLD cannot always brake the vehicle.
- Do not leave the vehicle when the motor is running and the Autohold function is on.

ⓘ ATTENTION

- When driving into the vehicle washing device and transporting the vehicle mechanism through the conveyor belt, the Autohold function must be off, otherwise the vehicle cannot move or deviate from the wheel path.

INTELLIGENT DRIVING

CRUISE CONTROL SYSTEM (CCS)

The CCS can set the vehicle speed to 30~110km/h. After setting the saved speed, the driver can release the accelerator pedal and the vehicle will drive at the set speed.

ACTIVATE THE CCS



Trigger conditions of CCS:

To activate CCS, the following conditions must be met:

- The vehicle speed is not less than 30km/h.
- The brake pedal is not depressed.
- The steering wheel is within a reasonable range of rotation.
- The vehicle is in 'D' gear.
- The ESC system is not activated.

Activate the CCS



Place the gear shift in the "P" position, select Cruise Control as the cruise mode in Vehicle Control-Assisted Driving on the Infotainment Screen, increase the vehicle speed to no less than 30km/h, and press the cruise button  on the steering wheel, the system will automatically store the current vehicle speed as the cruise speed, and the cruise control indicator  on the instrument panel will light up. At this time, the vehicle will start the cruise mode at the set speed without stepping on the accelerator pedal.

ADJUSTING THE CRUISING SPEED

In the CCS mode, press the CCS key  on the steering wheel to enter the speed setting mode.

Increasing the cruising speed: Roll the left scroll button on the steering wheel up, increasing the speed by 2km/h per scroll.

Reducing cruising speed: Roll the left scroll button on the steering wheel down, decreasing the speed by 2km/h per scroll.

In the ACC state, while stepping on the accelerator pedal, press the ACC button  on the steering wheel to set the current speed as the cruising speed.

NOTE

- In the cruising speed adjustment mode, press the left scroll button on the steering wheel to make the setting effective. In case of no operation for 2s, the setting will take effect automatically.

DEACTIVATE THE CCS

In the CCS On state, press and hold the CCS button  or step on the brake pedal to disable the CCS.

FUNCTION RESTRICTION

CCS is unavailable under the following conditions:

- CCS function fault.
- Vehicle in non-Drive gear mode.
- The vehicle speed is less than 30km/h or more than 110km/h.
- All vehicle doors not closed.
- Step on the brake pedal.
- Brake fluid alarm.

- EPB not released.
- The ESC system is deactivated.
- Tire pressure alarm.
- Use this system with caution at night, in dark situations such as underground garages, tunnels, and bridge culverts, and in severe weather conditions such as heavy rain, snow, and fog.

WARNING

- Do not use the CCS when driving on sections with dense traffic flow, slopes and multiple curves or slippery roads, otherwise incidents may occur.
- The set speed and the distance from the vehicle in front must adapt to the current traffic conditions.
- With the CCS system activated, the vehicle will accelerate when stepping on the accelerator pedal deeply, and may not slow down when lightly depressed.
- The CCS is only an assisted driving system and should be used carefully. The driver must always be ready to control the vehicle by himself and take full responsibility for the safety of the vehicle.

ATTENTION

- If the CCS has a fault, please contact the authorized dealer for check and repair in time.
- The CCS should be turned off in time after exiting the cruise status.
- When the vehicle is in "Reverse" gear during driving, the CCS function will exit.

ADAPTIVE CRUISE CONTROL (ACC)

The adaptive cruise control system (ACC) detects the relative distance, orientation and speed between the vehicle in front and the vehicle in the same lane by using the monocular camera on the front windshield, and automatically adjusts the relative

distance and speed during cruise. The control of the brake system and drive system not only realizes constant speed cruise, but also can maintain the headway set by the driver between the vehicle and the vehicle in front. The minimum settable speed of ACC is 30km/h, and the following and starting functions are provided.

ACTIVATE THE ACC

Available state of ACC

When ACC is selected as the cruise assist system, if the available conditions are met, the ACC indicator lamp  on the instrument cluster will be gray.

ACC is unavailable under the following conditions:

- ACC disabled, i.e., the ACC function is not selected in the center console screen.
- Failure of Adaptive Cruise Control (ACC).
- Vehicle in non-Drive gear mode.
- Instrument cluster speed < 5km/h.
- The turning radius of road curve is too small.
- All vehicle doors, the hood and liftgate are not closed.
- Step on the brake.
- Brake fluid alarm.
- B not released.
- Driver and front passenger seat belts are not fastened (when seated).
- Tire pressure alarm.
- It cannot be used in dark scenes such as nights, basements, tunnels, bridges and tunnels, and in severe weather conditions such as heavy rain, snow and fog.

NOTE

- When it's in the available state, press the ACC button  on the steering wheel at this time, and ACC will be turned on, and a text prompt will be displayed on the instrument cluster to indicate ACC is on; If ACC is in the unavailable state, the instrument cluster will prompt that ACC is not available.

ACC

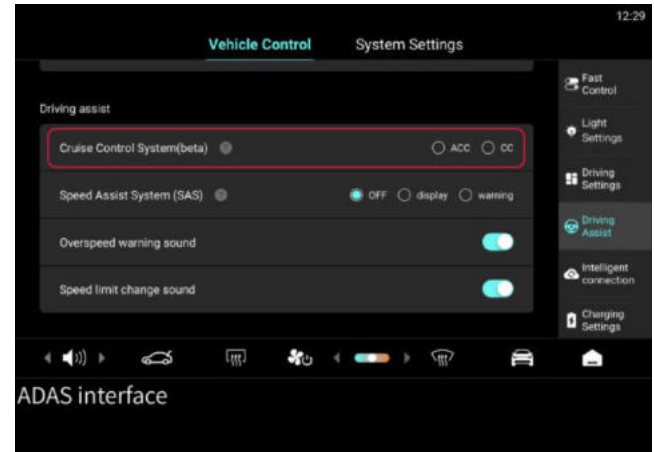

Place the gear shift in the "P" position, select Adaptive Cruise Control as the cruise mode in Vehicle Control-Assisted Driving on the Infotainment Screen, increase the vehicle speed to no less than 5km/h and press the cruise button  on the steering wheel to turn on the adaptive cruise control system.

- Press the ACC button , and the cruise speed is set to the current speed. If the current speed is less than 30 km/h, the cruise speed will be set to 30 km/h

- Press and hold the ACC button , and the cruise speed is set to the set speed at the last cruise

After the ACC is on, the ACC indicator lamp  on the instrument cluster will light up. At this time, the vehicle will start the cruise mode at the set speed without stepping on the accelerator pedal.

ADJUSTING THE CRUISING SPEED

In the ACC mode, press the ACC button  on the steering wheel to enter the cruise setting mode

Increasing the cruising speed: Roll the left scroll button on the steering wheel up, increasing the speed by 2km/h per scroll.

Reducing cruising speed: Roll the left scroll button on the steering wheel down, decreasing the speed by 2km/h per scroll.

Exit speed adjustment: Press the back button  on the right side of the steering wheel to exit the speed operation, and the cruising speed will return to the state before speed adjustment.

In the ACC state, while stepping on the accelerator pedal, press the ACC button  on the steering wheel to set the current speed as the cruising speed.

ADJUST ACC DISTANCE

In the ACC mode, press the ACC button  on the steering wheel to enter the cruise setting mode. 3 gears for ACC distance adjustment are optional.

Increase ACC distance: Press the Following distance+button  on the steering wheel to increase the following distance.

Decrease ACC distance: Press the Following Distance- button  on the steering wheel to decrease the following distance.

Exit ACC distance adjustment: Press the Back button  on the right side of the steering wheel to exit the distance adjustment operation, and the ACC distance will return to the state before adjustment.

NOTE

- In the cruising speed and distance adjustment mode, press the left scroll wheel to make the setting effective. In case of no operation for 2s, the setting will take effect automatically.
- When the following distance is set closer, the ACC system may generate vehicle braking in scenarios where you believe braking is not necessary or intended.

If the relevant target vehicle directly ahead is not correctly selected by the system, the ACC will accelerate the vehicle to the speed set by the driver.

In order to ensure the comfort of the ACC system, ACC will impose certain restrictions on the dynamic parameters of the vehicle.

- Maximum deceleration and rate of change of deceleration.
- Maximum acceleration and rate of change of acceleration.
- Speed in a curve.

DISABLE ACC

In the ACC On state, press and hold the ACC button  on the steering wheel or step on the brake pedal to disable ACC.

FUNCTION RESTRICTION

ACC may not respond or only have limited responses to the following target objects:

- Static obstacles such as broken-down vehicles.

-
- Trailers, muck trucks, oil tankers, trucks, or vehicles with irregular or nonstandard characteristics.
 - Another vehicle traveling in the same lane approaches the vehicle.
 - Drive from a straight road into a curve, and drive in a S-curve.
 - Bicycles and pedestrians.

The following cases may limit the functions of ACC, and the driver should pay extra attention to such cases including but not limited to:

- There are multiple vehicles running in parallel when approaching or making a turn.
- When the vehicle is on a slope, ACC may lose its target or misjudge the distance from the vehicle in front. When going downhill, ACC may increase the driving speed, resulting in exceeding the cruise speed.
- When only a portion of the body of a vehicle in an adjacent lane cuts into the front of the vehicle (especially large vehicles such as buses and trucks), ACC may not be able to recognize and respond to the case.
- When driving, the driver must observe the road conditions and be prepared to take correct measures as needed. Relying on ACC to fully decelerate the vehicle to avoid collisions may cause serious personal injury or death.

ACC may be canceled or unavailable in the following cases:

- The driver steps on the brake pedal.
- The gear is not in Drive.
- The active switch is canceled.
- The driving speed exceeds 130 km/h.
- The driver's seat belt is unfastened.
- Doors, hood and liftgate are open.
- Pull up the Electronic Parking Brake (EPB).
- The traction control system (TCS) is enabled.
- The autonomous emergency braking (AEB) is enabled.

- The airbag is deployed.
- The tire pressure value is abnormal.
- Wheel reversal (the vehicle speed is negative and the vehicle slides backwards).
- Dark night environment.
- Camera obscuration or blindness caused by mud, water stains, ice and snow; or blindness caused by light and dimness.
- Turn on the wiper for a long time.

When driving a vehicle by using the ACC system, the following behaviors are not allowed:

- Fully rely on this system.
- Use this system in environments with many pedestrians, bicycles or animals.
- Take your hands off the wheel.
- Keep your eyes off the road.

The following cases may cause camera recognition disorders, reduce the ACC performance, and cause function exit, including but not limited to:

- Installation position of camera changed.
- The camera is blocked or dirty.
- The recognition capability at night is reduced, and the surrounding environment is dim at dawn, dusk and night, and in tunnels.
- Sudden changes in ambient brightness, such as tunnel entrances or exits.
- A large shadow of a building, landscape, or large vehicle.
- The camera is directly exposed to light.
- The windshield in front of the camera has water, dust, scratches, grease, dirt, fog, ice and snow.

 **WARNING**

- Since the ACC system is not a safety system, obstacle detector or collision warning system, but a comfort system, the driver must always maintain control of the vehicle, observe the road conditions ahead, take corrective measures at any time and take full responsibility for the safety of the vehicle, and he must not rely entirely on ACC.
- The ACC is an assisted driving function that cannot cover all road scenarios, weather, and complex road conditions, thus the driver must carefully use it in conjunction with the prevailing weather conditions, road traffic conditions and visibility, and bear ultimate and full responsibility for the driving safety of the vehicle.
- Don't use the ACC function on winding roads with sharp turns, icy or slippery roads, or when driving at a uniform speed in adverse weather conditions (such as heavy rain, snow, dense fog, etc.) is unsuitable.
- During the use of the ACC function, the driver must always observe the road conditions ahead and be prepared to take immediate corrective actions. If the vehicle in front is too close and the vehicle speed is significantly higher than the speed of the vehicle in front, the ACC braking effect cannot guarantee safety, and the driver should timely take measures to reduce the vehicle speed to avoid collisions.
- During vehicle driving, a vehicle in the adjacent lane quickly and laterally moves to the front of the vehicle or is directly in front of the vehicle on the adjacent curve, which may lead to erroneous target judgment of the ACC system. ACC may cause the vehicle to brake when braking is not required or when the driver does not brake. To ensure driving safety, the driver must always pay attention to controlling the vehicle.
- The ACC can only achieve limited braking instead of emergency braking.
- At intersections, speed bumps, crossing zebra crossings or changing lanes, highway entrances and exits, ramps, or construction sections, the driver should control the vehicle and exit the ACC system to ensure driving safety.
- During vehicle driving, other vehicles suddenly quickly move or change lanes in close proximity to the front of the vehicle, and ACC fails to brake or decelerate in a timely manner.
- The ACC system is suitable for driving on highways and roads with good conditions. Do not use ACC on urban roads or under changing road conditions.
- ACC may respond to vehicles or objects that do not exist or are not in the driving lane, resulting in unnecessary or improper deceleration of the vehicle. The driver should always be prepared to control the vehicle and should not always rely on the ACC system.
- The ACC can only control the speed of the vehicle instead of the forward direction of the vehicle.
- For stationary vehicles or objects, especially when the vehicle in front suddenly leaves the driving lane where the vehicle is located, and stationary vehicles or objects are present in front of the lane, ACC cannot detect all objects, and may fail to brake. During usage, the driver must pay attention to the road conditions ahead and be prepared to quickly take corrective measures. Excessive reliance on ACC can cause serious personal injury or death.
- During the usage of the ACC function, the driver should always observe the surrounding environment of the vehicle and maintain a reasonable distance from the vehicle in front. When the vehicle in front cuts in quickly and in close proximity, or the relative speed is too low, the ACC system does not have enough time to reduce the relative speed. In this case, the driver must take timely measures to ensure driving safety.
- The ACC function may exit at any time for unknown reasons. During the usage of this function, the driver must observe the road conditions ahead and be prepared to take appropriate measures. The driver is responsible for always controlling the vehicle to ensure driving safety.
- The ACC system can enable the vehicle to drive out automatically after the vehicle has stopped for a short time and the driver has confirmed (lightly stepped on the accelerator

pedal). During this period, the driver must ensure no obstacles or other traffic participants, such as pedestrians, in front of the vehicle.

- The calibration of the camera may be affected by collision or vibration, which may reduce their performance. In this case, they may be recalibrated.
- Target selection may be delayed or disturbed when entering and exiting curves. In such situations, the vehicle with the ACC may not brake as expected or may brake too late.
- On a sharp turning road, such as a serpentine road, the vehicle with ACC turned on may accelerate as the vehicle in front disappears for a few seconds due to limitation in the field of view of the camera.
- When the vehicle is driving on the road conditions such as sharp turns, due to the limited recognition range of the system, it may result in failure to recognize the vehicle in front or a significant lag in recognition.
- In some cases (the vehicle in front is much slower than your vehicle, it changes lanes too quickly, or the safety distance is too small, etc.), the system does not have enough time to reduce the relative speed. In such cases, the driver must have appropriate response. The system may not give audible or visual warnings in every situation.
- If the distance between the vehicle with the ACC and the adjacent lane is too small (or the vehicle in the adjacent lane is too close to the lane in which the vehicle with the ACC is driving), the ACC may respond to the vehicle and brake.
- If a vehicle changes lanes to the path of the vehicle with the ACC and is within the detection range of the camera, it will be identified as the target vehicle. The ACC will respond depending on the target vehicle, which may cause forced braking or late braking.
- If the vehicle is driving in special road conditions such as circular parking lots, tunnels, etc. for a long time, it may have a functional failure for a short term. In such situations, the radar

can restore to normal functions by restarting the vehicle or driving a certain distance along the normal road.

- Structural modifications to the vehicle, e.g. lowering the chassis or changing the mounting plate of the vehicle front license plate, may affect the ACC system.
- The ACC may not provide adequate speed control due to limited braking capability and being on slopes. It may also misjudge the distance to the vehicle in front. The driving speed may be increased when going downhill, causing the vehicle to exceed the set speed (and possibly the limited speed of the road). When driving, the driver must observe the road conditions and be prepared to take correct measures as needed.
- For stationary or slow-moving objects, such as vehicles, tail end of the traffic flow, toll booths, bicycles or pedestrians, the ACC may only respond under special conditions, which are very specific.
- If the vehicle in front brakes suddenly (stops in emergency), there is a risk that the ACC cannot respond or react too slowly to the vehicle in front, resulting in too late braking. In such case, the driver will not receive the request of being prepared to control the vehicle.
- You are responsible for always determining and maintaining a safe following distance, do not rely on the ACC to maintain an accurate or appropriate following distance or reduce the vehicle speed sufficiently to avoid collisions. Make sure to observe the road conditions ahead and be prepared to take immediate corrective actions.

ATTENTION

- If the automatic emergency braking system is activated at the same time, the full-speed ACC will automatically exit after the automatic emergency braking system is triggered.
- If the ACC fails, the driving assist system fault warning indicator  on the instrument cluster will always be on. Please contact the authorized dealer for maintenance in time.

FOLLOWING AT A LOW SPEED

Following at a low speed is an extended function of the ACC. The relative distance and speed between the vehicle on the path ahead and your vehicle are detected through the millimeter-wave radar installed on the windshield, and the driving speed of your vehicle is controlled through the ADAS controller, achieving autonomous following the vehicle ahead at a low speed (speed < 30 km/h) without driver intervention.

FORWARD COLLISION WARNING (FCW)

Through the monocular camera installed on the windshield, the forward collision warning system detects the relative distance, orientation and speed between the front vehicle and your vehicle in the same lane, integrates other operation behaviors (such as stepping on brake pedal, stepping on accelerator pedal, etc.) of the driver to evaluate the risk degree of pre-collision, and warns the driver when necessary, and reminds the driver to take measures to avoid or alleviate collision in time in case of any collision risk.

ACTIVATING/DEACTIVATING THE FCW SYSTEM

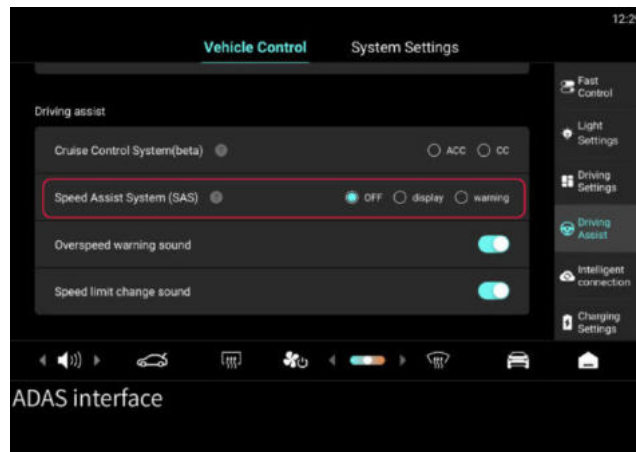

In the Vehicle Control - ADAS interface on the Infotainment Screen, tap to select the near, medium, far warning distance or deactivate the FCW function.

When the forward collision warning system of the Infotainment Screen is turned on, and the gear is in the position D, the instrument switches to the intelligent driving interface mode.

NOTE

- The forward collision warning is turned on by default. When you turn it off on the Infotainment Screen and start the vehicle again, the function is still turned off. You need to choose to turn it on manually.

- It is strongly recommended not to turn off the forward collision warning system. If it is turned off, the vehicle will not be able to provide warning or assist in braking when it is determined that a collision is likely to occur.
- Before using the forward collision warning, the driver should refer to this section to understand the usage guidelines and restrictions of relevant functions.

Trigger of the FCW system

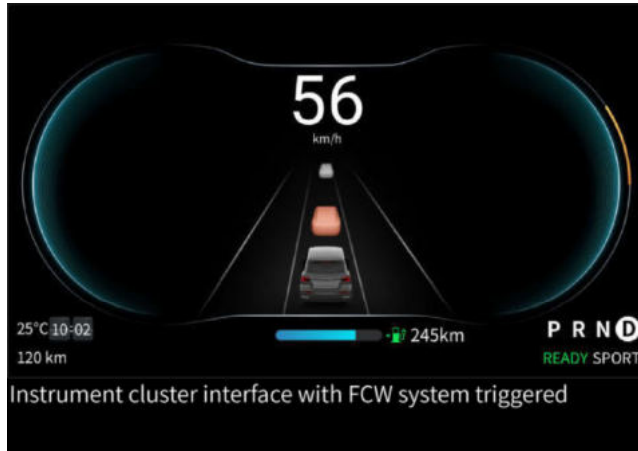

When the forward collision warning system is turned on during driving, and the vehicle speed is in 8~130km/h, if the system recognizes that there is a danger of collision with the vehicle in front, the instrument will display the trigger status of the forward collision warning system, reminding the driver to take measures to avoid or mitigate the collision.

FUNCTION RESTRICTION

In the following cases, the FCW system will not work:

- When the vehicle speed is less than 8km/h or greater than 130km/h.
- The forward collision warning system is turned off.
- The angle of the steering wheel is greater than 30°.
- The brake pedal is being stepped on or it is within 3s after releasing the brake pedal.
- The road turning radius is less than 200m.
- Heavy fog, rain or snow.
- The camera is blocked.
- The forward collision warning system has a fault. (This system fault icon will only be displayed on the instrument after the function is turned on)

The following cases may cause the camera recognition disorders, preventing the forward collision warning system from operating as expected. Including but not limited to:

- Installation position of camera changed.
- The camera is blocked or dirty.
- Poorer recognition capability at night.
- Dark surrounding environment, such as dawn, dust, night, and in tunnels.
- Sudden changes in ambient brightness, such as tunnel entrances or exits.
- A large shadow cast by a building, landscape, or large vehicle.
- The camera is directly exposed to the sun or light.
- Severe weather conditions such as rain, snow, fog and haze.
- Exhaust gas, water spray, snowflakes or dust raised by the vehicle in front fall on your vehicle.
- There is water, dust, minor scratches, oil stains, dirt, wipers, freezing, snow, etc. on windshield in front of the camera.
- Wet road surface.
- The camera is out of focus or has a fault.

The forward collision warning system may only recognize and respond to the vehicles, cyclists and pedestrians moving in the same direction and conforming the conditions. The system will not recognize and respond to the following targets, including but not limited to:

- Oncoming vehicles.
- Lateral-crossing vehicles.
- Animals.
- Traffic lights.
- Walls.
- Barricades (warning cones, etc.).
- Other non-vehicle objects.

In order to play the best role of the forward collision warning system, the system needs to recognize the body contours and main features of pedestrians as clear and complete as possible, that is, it can recognize the pedestrian's head, shoulders, arms, legs, the upper body and the lower body by combining standard human movement methods. The following cases may cause the failure in recognition of the pedestrian, preventing the forward collision warning system from operating as expected. Including but not limited to:

- The pedestrian is taller than 200 cm or shorter than 100 cm.
- The pedestrian wears larger clothes (such as raincoats, Han clothing, etc.), causing the main features (arms, legs, etc.) to be blocked and the contours not to be obvious.
- The pedestrian first appearing in the camera's field of view is relatively close to the vehicle.
- The pedestrian carries a large luggage or backpack.
- The color of the pedestrian's clothes and the background color of the scene have low contrast.
- The pedestrian holds an umbrella, which blocks the main features of the head, the arms, etc.
- The pedestrian bends or crouches down.
- The pedestrian is sitting in a wheelchair.

- The distance from one pedestrian to another is relatively close.
- The pedestrian wears clothing with reflective materials.
- The pedestrian is in dark places such as night roads, tunnels, etc.
- The speed of the pedestrian changes greatly when crossing the road.

In order to play the best role of the forward collision warning system, the system needs to recognize the body contours and main features of pedestrians and the contours of the bicycle as clear and complete as possible. The cyclist identified by the system is an adult riding a bicycle designed for adults. The following cases may cause the failure in recognition of cyclists, preventing the forward collision warning system from operating as expected. Including but not limited to:

- The features of the cyclist or the bicycle are blocked by clothing or other items, causing the contours not to be obvious.
- The bicycle carries large luggage.
- The bicycle is relatively fast.
- The color of the cyclist's clothes and the bicycle have low contrast to the background.
- The speed of the cyclist changes greatly.
- The cyclist first appearing in the camera's field of view is relatively close to the vehicle.
- The cyclist is riding in dark places such as night roads, tunnels, etc.
- People ride balance bikes, scooters, some motor scooters, electric bicycles in special forms, etc.

The following cases may cause the forward collision warning system not to work as expected because the target is not directly ahead, including but not limited to:

- The system will not respond to targets in the blind zone of the camera, such as the targets in the blind zones of the vehicle

corners and edges as well as those in the blind zones of the side and rear of the vehicle.

- They system may select an erroneous target or may be missed a target when approaching or making a turn.
- When the vehicle is on a slope, the system may lose its target or misjudge the distance to the target.
- When only a portion of the body of a vehicle in an adjacent lane cuts into the front of the vehicle (especially large vehicles such as buses and trucks), it may not be able to recognize and respond to the case.
- When a vehicle suddenly cuts behind the vehicle in front, or another vehicle suddenly cuts into or out of the front of the vehicle, the system may not recognize in time.

Due to the special or complicated road conditions in the following situations, the forward collision warning system may fail to work as expected, including but not limited to:

- Water accumulated, muddy, rugged and icy pavement, pavement with speed bumps, and pavement with obstacles.
- Traffic conditions with many pedestrians, bicycles, motor scooters or animals.
- Complex and changing traffic conditions, such as busy intersections, highway ramps, congested roads, etc.
- Tortuous roads, and roads with sharp turns.
- Uphill and downhill roads.
- Bumpy roads.
- Entrance and exit of tunnels.

The following cases may cause the forward collision warning system not to send an alarm, including but not limited to:

- When the driver is already braking, the forward collision warning system may not send an alarm.
- When the driver forcibly or suddenly steps on the accelerator pedal, the forward collision warning system may not send an alarm.

- When the driver spin the wheel sharply, the forward collision warning system may not send an alarm.

WARNING

- The forward collision warning system is an auxiliary function, which may not work in all driving situations, traffic conditions, weathers and road conditions, and it cannot replace focused driving and accurate judgment. Drivers are solely responsible for driving safety. The driver must observe the road conditions while driving, and he shall not rely on the forward collision warning system to warn or avoid possible collisions. Many factors can reduce or affect the performance, resulting in unnecessary, invalid or inaccurate warnings, brake interventions or omissions. Relying on the forward collision warning system to warn and avoid potential collisions may result in a serious injury or death.
- The forward collision warning system cannot guarantee that it can recognize special vehicles in all situations, especially at night. For example, tricycles, vehicles with damaged tail lamps or unclear tail contours, vehicles with blockages in the tail part, vehicles with irregular shapes, vehicles with the vertical plane of the tail being lower than a certain height, unloaded vehicle carrying vehicles, etc.
- The forward collision warning system may fail to recognize stationary or slow-moving vehicles, especially at night.
- The forward collision warning system may be falsely triggered in special scenes when the vehicle needs to drive onto a platform trailer or a wrecker.
- Before driving, the driver must confirm that there are no low obstacles that affect safety around the vehicle, avoiding related accidents caused by blocked vision.
- When the forward collision warning system is triggered, the driver needs to immediately brake to reduce the speed or avoid obstacles depending on the traffic conditions.

- The forward collision warning is only applicable to the warning of a frontal collision, and it will not work when the vehicle is in reverse gear.
- The monitoring range of the camera linked to the forward collision warning system is limited. Road and weather conditions may adversely affect the area that the forward collision warning system can monitor, and the driver must drive with caution.
- The FCW system may give an early warning when there is no risk of collision. Please concentrate and always observe the area ahead of the vehicle in order to predict whether any action needs to be taken.
- Warnings may be delayed or not given at all if traffic conditions or external influences prevent the cameras from properly detecting pedestrians, cyclists, vehicles and other objects.

ATTENTION

- When the forward collision warning system fails, the FCW warning indicator  on the instrument cluster will always be on. Please contact the authorized dealer for maintenance in time.

AUTONOMOUS EMERGENCY BRAKING (AEB)

The autonomous emergency braking (AEB) system adopts the monocular camera installed on the windshield to detect the relative distance and speed between the vehicle on the path ahead and your vehicle. With the AEB system activated, when the vehicle speed is in the range of 8~130km/h, and the driver brakes too late, applies insufficient braking force or does not brake at all, the system will initiate the AEB function to assist the driver to reduce or alleviate the collision. When it detects that the distance to the vehicle on the road ahead is too close, the system will control active deceleration when the vehicle speed is within the range of 60~130km/h, and will actively brake to a stop when the vehicle speed is within the range of 8~60km/h.

TURNING-ON AND TURNING-OFF OF AEB SYSTEM

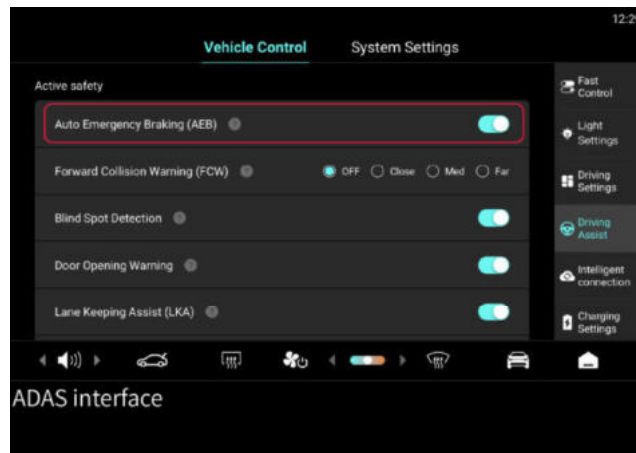

Turn on: In the Vehicle Control-Assisted Driving interface on the Infotainment Screen, slide the switch, and click OK according to the prompts on the interface to turn on the automatic emergency braking system.

Turn off: When the gear position is not in "D" and the automatic emergency braking system is turned on, in the Vehicle Control-Assisted Driving interface on the Infotainment Screen, slide the switch and click OK according to the prompts on the interface to turn off the automatic emergency braking system.

During the autonomous emergency braking process, if you step on the brake pedal again, the autonomous emergency braking will not exit. For safety reasons, do not intentionally drive close to the vehicle in front to test whether the autonomous emergency braking is triggered.

FUNCTION RESTRICTION

Due to the inherent performance limitations of the AEB, false triggering may inevitably occur during vehicle driving. Please use the AEB with special caution under the following conditions:

- Driving in adverse weather such as rainy days or snowstorms.
- There is a stationary obstacle ahead (such as a broken-down vehicle).
- No response to animals, crossing vehicles, and targets with unclear contours.
- Vehicles are driving in opposite directions in the same lane.
- Road conditions such as large curves or intersections where traffic crosses.
- Dark environment (poor lighting conditions) or poor visibility (caused by heavy rain and snow).
- When hard light (such as oncoming headlamp light or direct sunlight) interferes with the camera's field of view.
- The front windshield has conditions that block the camera's field of view (such as water mist, dust, or stickers).
- During driving, another vehicle in the adjacent lane suddenly and quickly cuts into the front of the vehicle, and the AEB cannot take braking measures in a timely manner.
- If the vehicle speed is greater than a certain speed, the autonomous emergency braking (AEB) cannot completely avoid collisions when pedestrians are detected.
- The autonomous emergency braking (AEB) does not work on retrograde vehicles.
- When the camera is blocked or dirty, the system will not work properly.

WARNING

- The AEB is only an auxiliary system. Please carefully read the prompt information on the function opening interface and

understand the restrictions on the use of the AEB when enabling it.

- The AEB can improve your driving safety, but it cannot exceed the laws of kinematics. Don't take advantage of the convenient features provided by the AEB to take risks while driving. The driver must be prepared to apply braking to the vehicle, reduce speed or avoid obstacles at any time.
- Several factors may lead to failure of emergency braking and improper or untimely emergency braking for the AEB system. The driver must always maintain control of the vehicle during driving, and take full responsibility for the safety of the vehicle.
- The AEB system does not prevent collisions. Once the AEB detects an emergency, it can only achieve limited braking to mitigate collision injuries. The driver should always observe the road environment, maintain an appropriate distance from the vehicle in front, and be ready for braking or steering at any time. Overreliance on the AEB by the driver may cause serious personal injury or death.
- During the autonomous emergency braking, the brake pedal will autonomously move down quickly. Do not place any objects under the pedal, otherwise they will affect the free movement of the pedal.
- Autonomous emergency braking is not a substitute for maintaining a safe driving distance from vehicles, cyclists, and pedestrians in front. Please avoid being too close to the vehicle in front, cyclists or pedestrians or driving fiercely.
- Autonomous Emergency Braking is only intended to lessen the impact of a frontal collision. Autonomous emergency braking does not operate when the vehicle is in Reverse gear.
- When emergency braking is triggered, during AEB braking intervention, if the driver forcibly steps on the accelerator pedal or turns the steering wheel, the AEB will stop working.
- If the vehicle has a visual or audible warning signal, the driver will take immediate measures to avoid danger to the vehicle.
- The AEB may give an early warning or apply braking in case of no risk of collision. Please concentrate on and always observe the

area ahead of the vehicle in order to predict whether any action needs to be taken.

- The braking distance will be extended on wet and slippery roads. If the anti-lock braking system (ABS), the traction control system (TCS), and the vehicle stability control system are activated, the capability of autonomous emergency braking to mitigate a collision may be reduced.

ATTENTION

- When the AEB system is turned on, the forward collision warning system will be turned on automatically.
- When the AEB system is turned off, the vehicle will not brake even if it detects a possible collision. You are recommended not to turn this feature off.
- If the AEB fails, the AEB fault warning indicator  on the instrument cluster will always be on. Please contact the authorized dealer for maintenance in time.

LANE DEPARTURE WARNING (LDW)

The LDW system uses a monocular camera installed on the front windshield to detect the lane markings on the road. When driving between 60 and 130km/h, the system continuously detects and recognizes lane markings in real-time through visual sensing. It collects data on the road ahead and integrates it with the vehicle's driving data. In the event of a lane departure without the driver activating the direction indicator lamp, the system issues an early warning signal to prompt the driver to take corrective actions promptly, ensuring the safety of both the driver and passengers.

TURNING-ON AND TURNING-OFF OF THE LANE DEPARTURE WARNING (LDW) SYSTEM

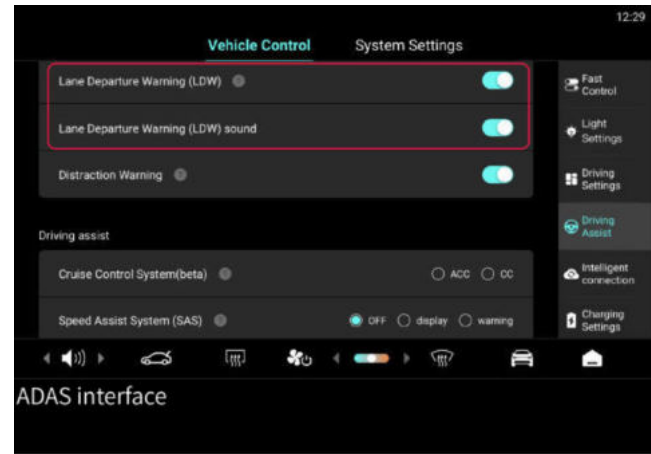

In the Vehicle Control - ADAS interface on the Infotainment Screen, slide to turn on or off the LDW system. After activating the LDW system, you can further turn on or off the LDW alert sound.

When the LDW system of the Infotainment Screen is turned on, and the gear is in the position D, the instrument switches to the intelligent driving interface mode.

NOTE

- The LDW system is turned on by default. When you turn it off on the Infotainment Screen and start the vehicle again, the

function is still turned off. You need to choose to turn it on manually.

TRIGGERING OF LDW



When the LDW system is on, the vehicle speed is within 60~130km/h, the LDW function is triggered when the system monitors that the vehicle deviates from the lane inactively and is driving on the lane line. The instrument cluster displays the state of the vehicle driving on the line, and prompts the driver to keep driving in the original lane through the prompt tone.

FUNCTION RESTRICTION

The LDW does not work in the following conditions:

- The LDW system is off.

- When the vehicle speed is less than 60km/h or more than 130 km/h.
- When the direction indicator lamp on the corresponding side is turned on.
- The lane marking lines on the road are not clear.
- Make a turn, turn around, or pass a winding or sharp-turn road.
- The road turning radius is less than 200m.
- Heavy fog, rain or snow.
- The camera is blocked.
- The monocular camera is not working.

Do not use the LDW System in the following conditions:

- At road crossings or intersections.
- Tire chains are used.
- The tires are excessively worn and the tire pressure is too low.
- When tires of different structures, manufacturers, brands or tread patterns are used.
- When the vehicle is driven on a road under construction (with obstacles like construction bulletin board, warning cones, etc.).
- On pavement with sharp turn, steep slope, ice or slippery surface, or in rainy, snowy or foggy days.

The following cases may cause the LDW system to fail to operate as expected or to autonomously exit, including but not limited to:

- When passing through a curve of a large curvature, e.g. expressway ramp, etc.
- Lane markings are unclear, worn, missing, crossed, or obscured by shadows of other vehicles or buildings or landscapes.
- The vehicle passes through the road sections without lane markings, such as non-standardized roads, intersections, construction areas, etc.
- When passing through a road section with special lane markings for, among others, reducing speed, traffic guidance, etc.
- When passing through an area where lanes are not clearly marked, e.g. areas where lane markings join together or

separate, expressway ramp entrance, urban intersection area, left turn waiting area, etc.

- Pavement with edges or other high-contrast lines, rather than lane markings, such as pavement joint, curb, etc.
- Lane markings cannot be recognized or are incorrectly identified due to height changes, such as on uphill and downhill slopes.
- Lane markings cannot be identified or identified incorrectly due to light, such as reflection of lane markings under strong lights, and poor visibility or insufficient light in bad weather conditions and at night.
- The lane markings on both sides are excessively or inadequately spaced.

The following cases may cause camera recognition disorders, resulting in the LDW system to fail to operate as expected or to autonomously exit due to recognition failure of the camera, including but not limited to:

- Installation position of camera changed.
- The camera is blocked or dirty.
- Poorer recognition capability at night.
- Dark surrounding environment, such as dawn, dust, night, and in tunnels.
- Sudden changes in ambient brightness, such as tunnel entrances or exits.
- A large shadow cast by a building, landscape, or large vehicle.
- The camera is directly exposed to light.
- Severe weather conditions such as rain, snow, fog and haze.
- Exhaust gas, water spray, snowflakes or dust raised by the vehicle in front fall on your vehicle.
- There is water, dust, minor scratches, oil stains, dirt, wipers freezing, snow, etc. on windshield in front of the camera.
- Wet road surface.

You are not recommended to use the LDW system in special and complicated road conditions, otherwise it may cause the LDW

system to fail to operate as expected or to autonomously exit, including but not limited to:

- Water accumulated, muddy, rugged and icy pavement, pavement with speed bumps, and pavement with obstacles.
- Traffic conditions with many pedestrians, bicycles, or animals.
- Complex and changing traffic conditions, such as busy intersections, highway ramps, congested roads, etc.
- Tortuous roads, and roads with sharp turns.
- Uphill and downhill roads.
- Bumpy roads.
- The road is narrow.
- Entrance and exit of tunnels.
- Non-standard roads.
- Roads without central isolation belt.

The above warnings and restrictions do not represent all situations that may interfere with the LDW system. Many factors can cause the LDW system to malfunction, and to avoid a collision, you need to stay alert during driving, keeping an eye on the road conditions to anticipate the need for take corrective actions as early as possible.

WARNING

- The LDW system is only an auxiliary system and cannot actively control the vehicle to change lanes or keep lanes. Do not rely on this function to prompt the driver that the vehicle is out of the lane boundary. The driver should always stay alert, pay attention to road conditions, actively control the vehicle and take full responsibility for vehicle safety.
- The LDW system may not always recognize lane markings. Due to adverse weather and other factors, it may cause missed or false triggering of functions. Therefore, the driver must concentrate on observing the road and traffic conditions and drive cautiously.

- Cracking of the windshield glass in the field of view of the front camera, coloration of the front windshield glass, the addition of coating that does not meet the specifications, the placement of objects that reflect light on the instrument cluster, and the addition of any objects that affects the sight line of the camera may affect the normal operation of the system.
- The sound of the sound system inside the vehicle or the noise outside the vehicle may prevent the driver from hearing the warning buzzer. Please avoid interference as much as possible and concentrate on observing the road conditions.
- Do not rely too much on the LDW system, do not deliberately test the trigger of the function, or deliberately wait for the trigger of the function. Due to the inherent restraints of the system performance, false trigger and missed trigger cannot be avoided completely.
- If the driver turns on the direction indicator lamps and changes lanes in the direction of the direction indicator lamp, the LDW system will not work.
- When driving on a steep slope or a curved road, the distance to the vehicle in front is too close or the vehicle in front blocks the lane markings, the LDW system may not give an alarm.
- When the vehicle is greatly bumped due to road conditions during driving, and when the driver accelerates, decelerates or turns the steering wheel quickly, the LDW system may not give an alarm. If the driver drives on the lane marking, the lane marking is not obvious, or if the lane marking is too thin, worn, blurred or covered with dirt/snow, the LDW system may be suppressed.
- When the lane is too wide or too narrow, the number of lanes is increased or decreased, and the lane markings are changed in a short time, such as ramps or expressway exits, or when the lane markings are complicated, the LDW system may be suppressed.
- When driving on a steep slope or a curved road, the distance to the vehicle in front is too close or the vehicle in front blocks the lane markings, the LDW system may be suppressed.
- When the vehicle is greatly bumped due to road conditions during driving, and when the driver accelerates, decelerates or

turns the steering wheel quickly, the functions of the LDW system may be suppressed.

- For your driving safety, please do not test the lane departure warning function by yourself. The field of view for the camera shall not be blocked by objects or interfered by strong light. The function will temporarily exit when the field of view is temporarily blocked or interfered by strong light, and it will resume autonomously after the field of view is normal. If it cannot be restored by itself, please contact the authorized dealer.
- When the vehicle gives visual, audible and tactile warnings, it is your responsibility to take immediate measures to avoid further danger to the vehicle. Do not rely on the intervention of the lane keeping assist (LKA) system.

ATTENTION

- When the LDW system fails, the LDW fault warning indicator  on the instrument cluster will always be on. Please contact the authorized dealer for maintenance in time.

LANE KEEPING ASSIST (LKA)

The lane keeping assist (LKA) system detects the current lane information status of your vehicle in the forward direction through the monocular camera installed on the front windshield. When the vehicle speed is within 60~130km/h and there is a trend of lane departure or when the lane marking is about to be crossed, the LKA system will apply slight steering assistance to the steering wheel for correcting deviations to reduce the possibility of the vehicle deviating from the lane. If the vehicle deviates from the lane too much, the LKA system will provide appropriate visual and audio prompts.

TURN ON OR OFF THE LKA SYSTEM

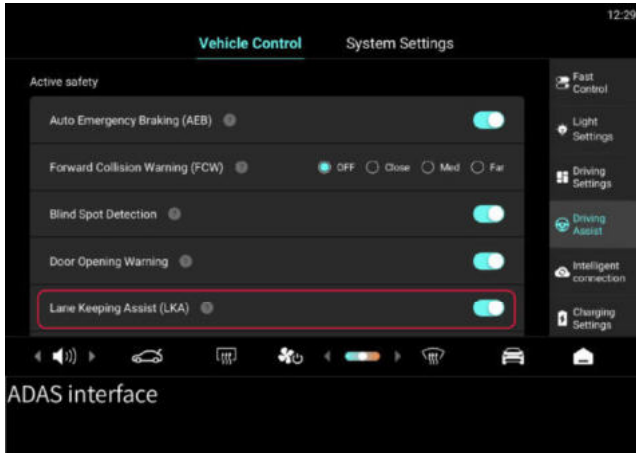

On the Vehicle Control - ADAS interface of the Infotainment Screen, slide to turn on or off the lane keeping assist (LKA) system. After the system is turned on, when the vehicle speed is increased to above 60 km/h, the LKA system will be activated.

NOTE

- When the speed is lower than 60 km/h, the lane keeping assist (LKA) system will not be activated in the lane departure state.

TRIGGER OF LANE KEEPING ASSIST SYSTEM



When the lane keeping assist (LKA) system is turned on, and the vehicle speed is within 60 km/h-130km/h, and the vehicle is detected to have a trend of non-active deviation to the adjacent lane or the lane marking is about to be crossed, the LKA system will apply slight steering correction assistance to the steering wheel to reduce the possibility of the vehicle deviating from the lane. If the vehicle deviates from the lane too much, the LKA system will provide appropriate visual and audio prompts.

FUNCTION RESTRICTION

The lane keeping assist system does not work in the following conditions:

- The Lane Keeping Assist (LKA) system is turned off.
- The speed is below 60km/h.

- When the direction indicator lamp on the corresponding side is turned on.
- The lane marking lines on the road are not clear.
- Make a turn, turn around, or pass a winding or sharp-turn road.
- The road turning radius is less than 200m.
- Heavy fog, rain or snow.
- The camera is blocked.
- The monocular camera is not working.

Do not use the LKA system in the following conditions:

- At road crossings or intersections.
- The vehicle drives on roads other than main roads or expressways.
- When tires of different structures, manufacturers, brands or tread patterns are used.
- When the vehicle is driven on a road under construction (with obstacles like construction bulletin board, warning cones, etc.).
- On pavement with sharp turn, steep slope, ice or slippery surface, or in rainy, snowy or foggy days.

The following cases may cause the LKA system to fail to operate as expected or to autonomously exit, including but not limited to:

- When passing through a curve of a large curvature, e.g. expressway ramp, etc.
- Lane markings are unclear, worn, missing, crossed, or obscured by shadows of other vehicles or buildings or landscapes.
- The vehicle passes through the road sections without lane markings, such as non-standardized roads, intersections, construction areas, etc.
- When passing through a road section with special lane markings for, among others, reducing speed, traffic guidance, etc.
- When passing through an area where lanes are not clearly marked, e.g. areas where lane markings join together or separate, expressway ramp entrance, urban intersection area, left turn waiting area, etc.

- Pavement with edges or other high-contrast lines, rather than lane markings, such as pavement joint, curb, etc.
- Lane markings cannot be recognized or are incorrectly identified due to height changes, such as on uphill and downhill slopes.
- Lane markings cannot be identified or identified incorrectly due to light, such as reflection of lane markings under strong lights, and poor visibility or insufficient light in bad weather conditions and at night.
- The lane markings on both sides are excessively or inadequately spaced.

The following cases may cause the LKA system to fail to operate as expected or to autonomously exit due to recognition disorders of the camera, including but not limited to:

- Installation position of camera changed.
- The camera is blocked or dirty.
- Poorer recognition capability at night.
- Dark surrounding environment, such as dawn, dust, night, and in tunnels.
- Sudden changes in ambient brightness, such as tunnel entrances or exits.
- A large shadow cast by a building, landscape, or large vehicle.
- The camera is directly exposed to light.
- Severe weather conditions such as rain, snow, fog and haze.
- Exhaust gas, water spray, snowflakes or dust raised by the vehicle in front fall on your vehicle.
- There is water, dust, minor scratches, oil stains, dirt, wipers freezing, snow, etc. on windshield in front of the camera.
- Wet road surface.

You are not recommended to use the LKA system in special and complicated road conditions, otherwise it may cause the LKA system to fail to operate as expected or to autonomously exit, including but not limited to:

- Water accumulated, muddy, rugged and icy pavement, pavement with speed bumps, and pavement with obstacles.
- Traffic conditions with many pedestrians, bicycles, or animals.
- Complex and changing traffic conditions, such as busy intersections, highway ramps, congested roads, etc.
- Tortuous roads, and roads with sharp turns.
- Uphill and downhill roads.
- Bumpy roads.
- The road is narrow.
- Entrance and exit of tunnels.
- Non-standard roads.
- Roads without central isolation belt.

The above warnings and restrictions do not represent all situations that may interfere with the LKA system. Many factors can cause the LKA system to malfunction, and to avoid a collision, you need to stay alert during driving, keeping an eye on the road conditions to anticipate the need for take corrective actions as early as possible.

WARNING

- The LKA is only an auxiliary system. Please carefully read the prompt information on the function opening interface and understand the restrictions on the use of the AEB when enabling it.
- The LKA cannot replace the driver in monitoring traffic status. The driver should always be alert to the surrounding environment and bear full responsibility for vehicle safety.
- The driver should always hold the steering wheel and actively control the vehicle.
- The LKA system may not always recognize lane markings. Due to adverse weather and other factors, it may cause missed or false triggering of functions. Therefore, the driver must concentrate on observing the road and traffic conditions and drive cautiously.

- The LKA system has limited steering force and can only provide slight steering assistance for correcting deviations, but cannot completely prevent vehicles from deviating from the lane. Therefore, do not rely on the LKA system to control the direction. The driver should always be prepared to increase the steering force, especially in curves.
- The LKA system cannot continuously control the direction of the vehicle, that is, it cannot keep the vehicle in the middle of the lane all the time.
- When the lane marking has a non-smooth transition, the steering wheel may be adjusted significantly, please drive cautiously.
- When driving on a curve and departing from the lane, the system may not have a separate prompt to exit the function, please drive cautiously.
- Do not place objects that reflect light on the instrument panel, because these objects are not only easy to dazzle the driver, but also may reflect light into the field of view of the front camera of the system, which may affect the normal operation of the system.
- Do not rely too much on the LKA system, do not deliberately test the trigger of the function, or deliberately wait for the trigger of the function. Due to the inherent restraints of the system performance, false trigger and missed trigger cannot be avoided completely.
- When the lane keeping assist (LKA) system exits unexpectedly, such as when the curve is too large, the road surface is inclined, the lane markings are not clear, the lane is too wide or too narrow, etc., the system will only prompt the user to exit the function through the status change of the lane markings on the instrument. Drivers must take full responsibility for driving safety.
- The Lane Keeping Assist (LKA) system do not always recognize markings, and it may sometimes recognize poor-quality pavements, certain road structures or objects to be lane markings by mistake. In such cases, make sure to turn off the lane keeping assist (LKA) system immediately.

- Excessive tire wear, or low tire pressure will reduce the performance of the lane keeping assist (LKA) system.
- When the road marking is close to the curb, and the road marking is not clear at this time, such as in the boundary lane of the tunnel, switching between the lane marking and the curb may occur during the camera recognition, causing the steering wheel to swing back and forth, please drive cautiously.

ⓘ ATTENTION

- If the lane keeping assist (LKA) system fails, the LKA fault warning indicator 🚨 on the instrument cluster will always be on. Please contact the authorized dealer for maintenance in time.

BLIND SPOT DETECTION (BSD)

The BSD system continuously detects the vehicle's rear blind spots when the vehicle speed is at least 13km/h, and it alerts the driver with warning indicators installed on the side rearview mirrors when another vehicle enters the blind spot range.

TURN ON OR OFF THE BSD SYSTEM

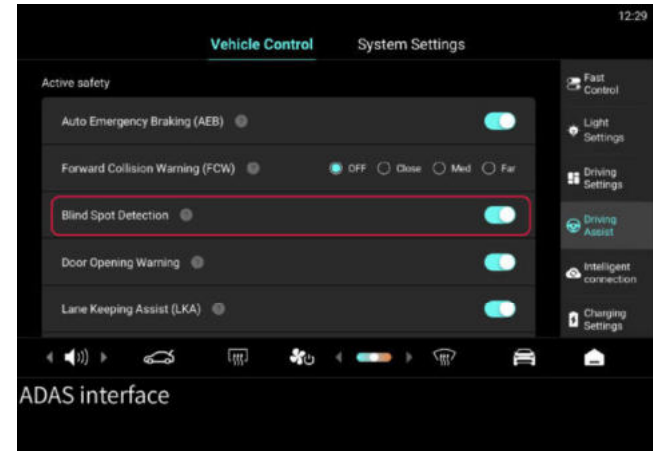

In the Vehicle Control - ADAS interface of the Infotainment Screen, slide to turn on or off the BSD system.

When the BSD system of the Infotainment Screen is turned on, and the gear is in the position D, the instrument switches to the intelligent driving interface mode.

ⓘ NOTE

- The BSD system is turned on by default. When you turn it off on the Infotainment Screen and start the vehicle again, the function is still turned off. You need to choose to turn it on manually.

TRIGGER OF THE BSD SYSTEM

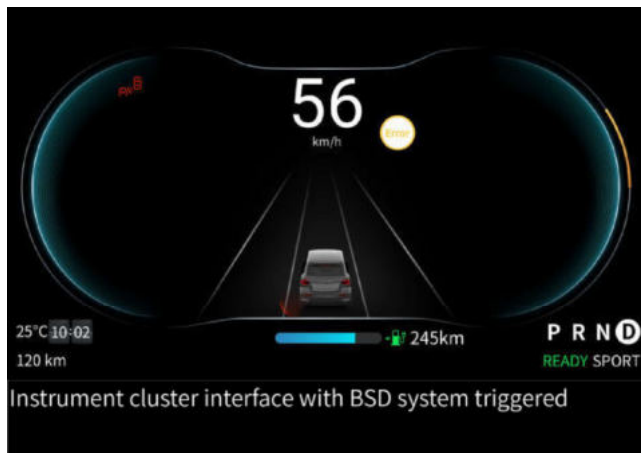

When the BSD system is activated during driving and the vehicle speed is at least 13km/h, if the system detects another vehicle entering the blind spot range, the instrument cluster will display the triggered BSD system, reminding the driver to take measures to avoid or mitigate the collision.

FUNCTION RESTRICTION

The system may also issue an alarm when there is no vehicle in the blind spot, and the system may issue a false alarm in the following situations:

- Crash barriers of the road.
- Concrete walls of the highway.
- Construction areas.
- Sharp turns around buildings.

- Shrubs and trees.

The BSD system does not work in the following conditions:

- The rear vehicle changes lanes at the last minute.
- The vehicle speed is less than 11km/h.
- Rear vehicles are detected too late in scenarios such as sharp turns, steep slopes, etc.
- Rear vehicle's relative speed is too fast.
- Target vehicles are obscured.
- The radar cross-section of the target (such as a bicycle, a scooter) is too small.
- The radius of the bend is too small, or when entering and exiting the bend.
- Bad weather, such as rain, snow and other weather.

⚠ WARNING

- The BSD system may experience delays, and the driver should always pay attention to the vehicle's driving conditions.
- The BSD system cannot replace the driver in monitoring traffic status. The driver should always be alert to the surrounding environment and bear full responsibility for vehicle safety.
- The driver should not rely on the BSD system too much, intentionally test its triggering function, or wait intentionally for it to be triggered. Due to the inherent restraints of the system performance, false trigger and missed trigger cannot be avoided completely.
- In order to ensure safety, the driver must not solely rely on the BSD radar, and must maintain the correct use of the interior rearview mirror and the side mirrors.
- Using the BSD function does not imply that the driver can be inactive and relaxed. Safely changing lanes is always the driver's responsibility.
- In case of sharp turns, the BSD system may not work.

- When a target vehicle approaches your vehicle from rear at a high speed, the BSD system may not be able to provide adequate warning function.
- The BSD system cannot replace safe driving and the use of the interior rearview mirror and side mirrors.
- If unrelated objects in the side or rear area (such as large roadside barriers during road repairs, large billboards on the roadside, or reflectors in tunnels with large cross-sectional areas, etc.) are mistakenly identified as detected target vehicles, the BSD system will issue a warning.
- The driver should ensure the proper functioning of the BSD system and keep the installation area of the BSD radar in good condition. If covered with mud, snow, etc., it should be promptly cleaned.

DOOR OPEN WARNING (DOW)

The DOW system detects approaching vehicles from the adjacent lane when the vehicle is stopped. It alerts the driver when there is a risk of opening the door, thereby avoiding potential safety accidents.

TURN ON OR OFF OF THE DOW SYSTEM

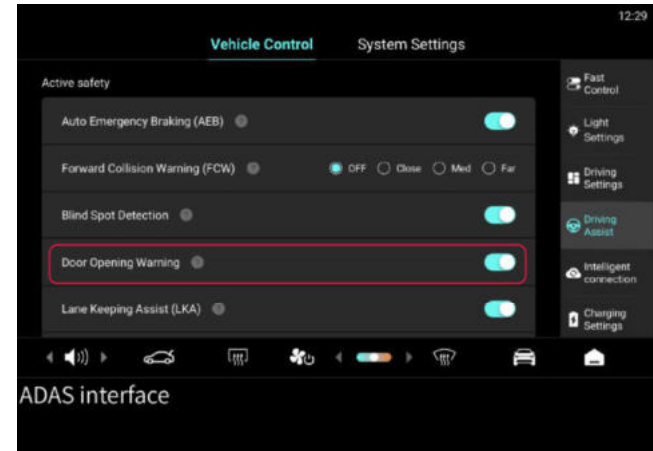

On the Vehicle Control - ADAS interface of the Infotainment Screen, slide to turn on or off the DOW system.

TRIGGER OF THE DOW SYSTEM



When the DOW system is activated and the vehicle speed is not higher than 3 km/h, if the system detects a vehicle approaching from the rear in the adjacent lane and detects a risk of opening the door, the warning indicator on the instrument cluster illuminates, and a reminder message is displayed, alerting the driver to be cautious when opening the door.

FUNCTION RESTRICTION

The system may also issue a warning when there are no vehicles in the monitoring area. In the following situations, the system may generate false alarms:

- Crash barriers of the road.
- The speed is greater than 5 km/h.
- Concrete walls of the highway.

- Construction areas.
- The vehicle is parked too close to vehicles behind it.
- Shrubs and trees.

⚠ WARNING

- The DOW cannot replace the driver in monitoring traffic status. The driver should always be alert to the surrounding environment and bear full responsibility for vehicle safety.
- Do not rely too much on the DOW system, do not deliberately test the trigger of the function, or deliberately wait for the trigger of the function. Due to the inherent restraints of the system performance, false trigger and missed trigger cannot be avoided completely.
- The DOW system may not function effectively in all situations. Depending on sensor performance and the complexity of the traffic environment, instances of no alarm or false alarm may occur. Actively observing the surrounding environment is the most effective measure to ensure personal safety. Please do not rely too much on the DOW function.
- The DOW function is only effective when the vehicle is stationary or traveling slowly.

INTELLIGENT SPEED ASSIST (ISA)*

When the ISA system will integrate the speed limit signs on the road and the navigation map information through the monocular camera installed on the front windscreen, and display the speed limit information on the instrument cluster. It provide visual and auditory warnings to alert the driver after exceeding the speed limit. Additionally, it can prompt the driver to actively reduce the speed to comply with the speed limit through speed limit reminders displayed on the instrument cluster.

TURN ON OR OFF THE ISA SYSTEM

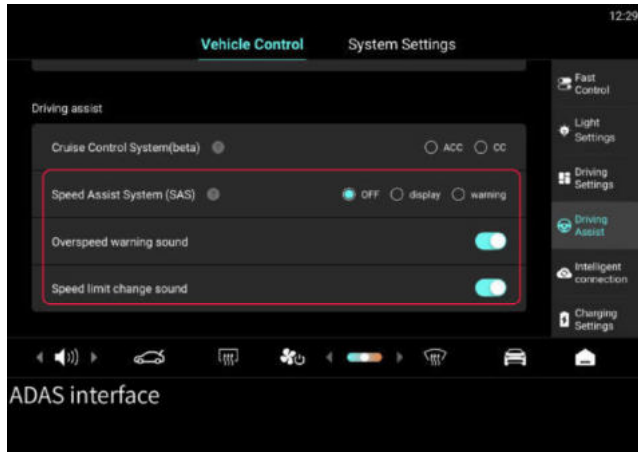

In the Vehicle Control - ADAS interface on the Infotainment Screen, tap to select the ISA Off, speed limit display or speed limit warning. When the speed limit warning function is activated, you can toggle on or off the overspeed warning alarm and speed limit change alert sound.

TRIGGER OF THE ISA SYSTEM

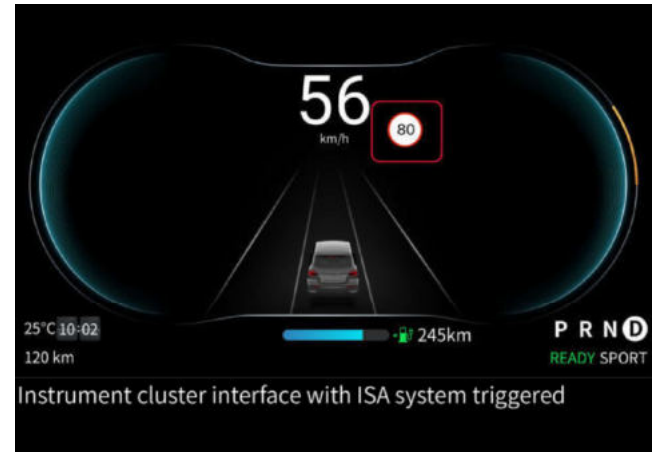

When the ISA system is activated, it will integrate the speed limit signs on the road recognized by the monocular camera and the navigation map information, and display the speed limit information on the instrument cluster. After recognizing and displaying the speed limit information, the system compares it with the real-time speed. If the speed does not exceed the speed limit, only the speed limit sign icon is displayed on the instrument cluster. If the speed limit is exceeded, the speed limit sign icon on the instrument cluster flashes, when the alarm conditions are met, the system will give an audible warning.

The system will give an alarm sound when any of the following conditions is met:

- The real-time speed is not less than 130% of the speed limit information and lasts for 3 seconds or more.

- The real-time speed is not less than 120% of the speed limit information and lasts for 4 seconds or more.
- The real-time speed is not less than 110% of the speed limit information and lasts for 5 seconds or more.
- The real-time speed is not less than 100% of the speed limit information and lasts for 6 seconds or more.

FUNCTION RESTRICTION

The ISA system can only function properly when the speed limit signs are clearly visible. It may not be able to recognize or may misrecognize in certain situations:

- Signs are not compliant with relevant regulations.
- Signs are faded, reflective, or unclear, etc.
- Signs are located on bends.
- Signs have improper angles.
- Signs are partially or completely obscured.
- Signs are positioned too far or too high.
- Signs are affixed to the road surface.

The ISA system does not work in the following conditions:

- The ISA system is deactivated.
- There is a severe weather condition such as heavy fog, snow or rain.
- The camera is blocked.
- The ISA system fails.
- Driving too close to the vehicle in front obstructs the detection range of the camera.

WARNING

- The ISA system can only recognize the speed-related signs, and cannot identify other road signs.
- The ISA system can only recognize the maximum speed limit of this road. Do not rely on traffic sign recognition to determine the

appropriate speed, and always drive within the safe speed range according to the speed limit and road conditions.

- ISA system cannot work under all conditions, and the driver shall always take the ultimate responsibility for the safe driving of the vehicle and abide by the applicable laws and road traffic rules.
- The speed limit signs along the road are unclear or distorted, tilted, reflective, partially covered, causing the reduced capability or inability of recognition of the camera.
- The ISA system may not be able to detect the road speed limit signs when the vehicle is running on winding or narrow roads or those with coexistence of people and vehicles or steep slopes, or passing through tunnels.
- The ISA system is only an auxiliary system and cannot completely replace the driver's judgment of the road speed limit information. In any case, the driver shall pay attention to the road information signs, drive carefully and take full responsibility for vehicle safety.
- The ISA system can only recognize speed limit signs and give alerts, and does not participate in the active control of the vehicle. The vehicle is always under the control of the driver, so please drive reasonably.
- Do not rely on the ISA system to determine the appropriate limit speed or driving speed, and always drive within the safe speed range according to the traffic and road conditions.
- The ISA system does not always recognize the speed limit signs accurately. It may misjudge road conditions and provide speed limits that may be different on adjacent roads, or the camera may misidentify the speed limit sign and display the limit speed on the instrument cluster.
- The performance of the ISA system is affected by weather, illumination and the visual quality of road signs. Driving at night, backlight, sunset, rainy days, fog, haze, ice and snow coverage, sand, sudden change of brightness, etc. may lead to a decline of the recognition capability, causing speed limit signs unable to be recognized.

NOTE

The ISA Map data can be upgraded via online every year (free of charge) within 7 years to ensure the accuracy of the ISA system in identifying speed limit signs.

- When the ISA map of a certain area is updated and you drive to this location, the ISA map data will be automatically updated.
- The updated ISA map data will only take effect after the vehicle is powered off and then powered on again.

DRIVER DROWSINESS AND ATTENTION WARNING (DDAW)*

The Driver Drowsiness and Attention Warning (DDAW) uses the facial recognition camera installed on the left front A pillar and auxiliary detection capabilities of some IVI signals to monitor the driver's fatigue state in real time during normal running of the vehicle. Upon detecting signs of fatigue driving (e.g. yawning, closing eyes, opening and closing eyes, etc.), the DDAW system analyzes such behavior and alerts the driver through visual and audible warnings to warn the driver and correct wrong driving behaviors.

TRIGGER OF THE DDAW SYSTEM

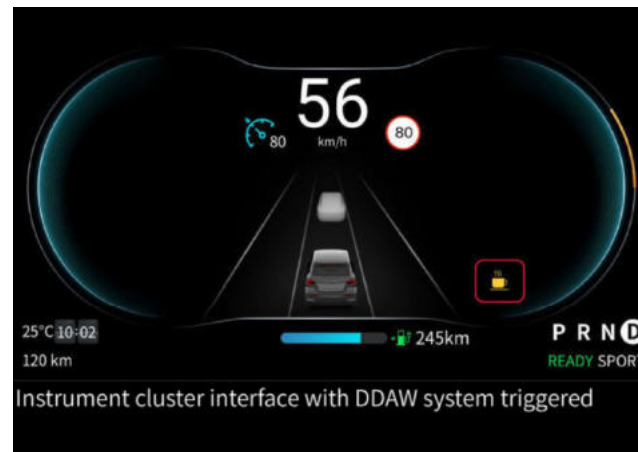

After the vehicle is started, the DDAW system is turned on by default. When the gear is in 'D' and the speed is within 65-130km/h, if the system detects signs of driver fatigue, the DDAW system will be activated, and the DDAW warning indicator on the instrument cluster illuminates, a pop-up warning will be displayed on the Infotainment Screen, and a prompt sound reminds the driver to drive safely.

FUNCTION RESTRICTION

The DDAW system does not work in the following conditions:

- Vehicle in non-Drive gear.
- The vehicle speed is less than 65 km/h.
- The face recognition camera sensor fails or the camera is blocked etc. In some cases, it may affect or fail to detect the

driver drowsiness, resulting in the system not issuing corresponding warnings or being partially unavailable.

- Direct sunlight, oncoming headlamps, and other sources of interference.
- The driver's seating posture is unusually beyond the typical driving posture range, or the driver's face is within the blind spot of the camera.
- The driver's vision is obstructed, including but not limited to sunglasses with low light transmittance, polarized lenses, tinted sunglasses, and obstructions by eyeglass frames.
- The driver wears a hat, scarf, headscarf or other accessories that may change the shape of the head.
- When the driver wears a mask or other objects obstructing the mouth.
- The driver's face is partially illuminated by light or his facial features are incomplete.

WARNING

- The DDAW system is only an auxiliary system and cannot guarantee effective recognition and alerting in all circumstances. It cannot replace the driver's subjective judgment. Do not rely solely on the system's prompts; the driver must always maintain control of the vehicle and drive in accordance with road laws and regulations, taking full responsibility for the vehicle.
- Focused driving and timely rest breaks are essential. When fatigue warning occurs, the driver should adjust the driving behavior promptly or stop for a rest in a safe manner.
- The DDAW system cannot actively intervene in driving operation. The driver always has responsibility to drive the vehicle safely and prudently.
- The DDAW system is a ADAS system, and cannot ensure proper functioning under all circumstances. The driver should be always responsible for driving the vehicle safely, obeying current laws and traffic regulations.

- Do not drive while fatigued. The driver has the responsibility to maintain healthy and remain alert while driving.

NOTE

-

If the DDAW system has a recoverable short-term fault (such as: blocked camera, etc.), the DDAW short-term fault warning lamp in the instrument  will light up to inform the driver of the fault of the system and the failure of relevant fatigue detection functions. After the fault is repaired, the DDAW system recovers in real time.

-

In case of long-term or unrecoverable faults occur to the system (such as open circuit of the DDAW camera), the DDAW fault warning lamp on the instrument cluster  will be on. After the long-term (or unrecoverable) fault is repaired, the DDAW system recovers in real time.

ADVANCED DRIVER DISTRACTION WARNING (ADDW)*

The Advanced Driver Distraction Warning (ADDW) uses the camera installed on the left front A pillar and partial MMI information to monitor the driver's attention during driving, when the driver distraction (e.g. eye movement, head movement, body tilting and other behaviors) is detected, it will give warnings to warn the driver and correct wrong driving behaviors.

TURN ON OR OFF THE ADDW SYSTEM

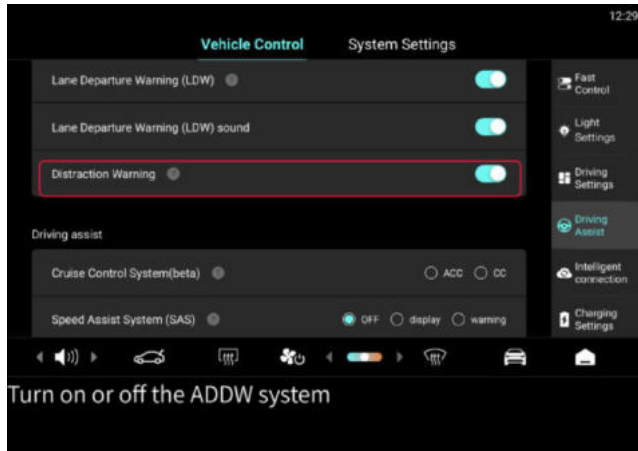

In the Vehicle Control - ADAS on the Infotainment Screen, slide to toggle on or off the ADDW system.

TRIGGER OF THE ADDW SYSTEM



When ADDW is turned on, the gear is in "D" and the speed is at least 10km/h, if the system detects signs of driver distraction or diverted attention, the ADDW system will be activated, and the ADDW warning lamp on the instrument cluster illuminates, and a prompt sound reminds the driver to drive safely.

FUNCTION RESTRICTION

The ADDW system does not work in the following conditions:

- The vehicle speed is less than 10 km/h.
- Vehicle in non-Drive gear.
- The face recognition camera sensor fails.

In some cases, it may affect or fail to detect the driver's distractions, resulting in the system not issuing corresponding warnings or being partially unavailable.



- Direct sunlight, oncoming headlamps, and other sources of interference.
- The driver's seating posture is unusually beyond the typical driving posture range, or the driver's face is within the blind spot of the camera.
- The driver's vision is obstructed, including but not limited to sunglasses with low light transmittance, polarized lenses, tinted sunglasses, and obstructions by eyeglass frames.
- The driver wears a hat, scarf, headscarf or other accessories that may change the shape of the head.
- When the driver wears a mask or other objects obstructing the mouth.
- The driver's face is partially illuminated by light or his facial features are incomplete.

WARNING

- The ADDW system is only an auxiliary system and cannot guarantee effective recognition and alerting in all circumstances. It cannot replace the driver's subjective judgment. Do not rely solely on the system's prompts; the driver must always maintain control of the vehicle and drive in accordance with road laws and regulations, taking full responsibility for the vehicle.
- Focused driving is essential. When distraction warning occurs, the driver should adjust the driving behavior promptly.
- The ADDW system cannot actively intervene in driving operation. The driver always has responsibility to drive the vehicle safely and prudently.
- The ADDW system is a ADAS system, and cannot ensure proper functioning under all circumstances. The driver should be always responsible for driving the vehicle safely, obeying current laws and traffic regulations.

- Do not drive while distracted. The driver has the responsibility to maintain focus and remain alert while driving.

NOTE

- When the vehicle is powered on and performs self-checks, the DDAW/ADDW indicator lamp is turned off after a few seconds.
- In case of recoverable short-term faults occur to the ADDW system (such as blocked camera), the DDAW short-term fault warning lamp on the instrument cluster  will be on to warning the driver of the system fault and the failure of related functions. After the fault is repaired, the ADDW system recovers in real time.
- In case of long-term or unrecoverable faults occur to the ADDW system (such as open circuit of the ADDW camera), the ADDW fault warning lamp on the instrument cluster  will be on. After the long-term (or unrecoverable) fault is repaired, the ADDW system recovers in real time.

DRIVING AT NIGHT

LAMP SWITCH

Most of the lamp control is integrated in the Infotainment Screen. You can control the lamp off button as well as position lamps, low beam headlamps, the auto lamp, headlamp leveling, the rear fog lamp switch, the reading light and the Follow Me Home through the Infotainment Screen.

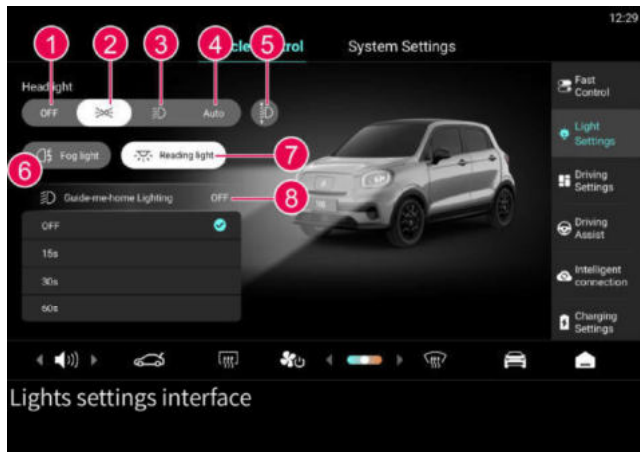

1. Lamps off
2. Position lamp switch
3. Low beam headlamp switch
4. Auto lamp switch
5. Headlamp leveling button
6. Rear fog lamp switch
7. Reading light switch
8. Follow Me Home switch

Lamps off: When illuminated, all exterior lamps are off.

Position lamp switch: Tap it to turn on the front position lamp, the rear position lamp, the license plate lamp and the button backlight.

Low beam switch: Tap the low beam switch to turn on low beam headlamps and position lamps at the same time.

Auto lamp switch: When illuminated, the auto lamp function is activated. When the light outside the vehicle gradually becomes dark, e.g. the vehicle enters a tunnel or a garage, the position lamps and the low beam headlamps will be automatically turned on at the same time. When the light outside the vehicle is sufficient, the position lamps and the low beam headlamps will be automatically turned off at the same time.

Fog light switch: Tap the rear fog light switch to turn on the rear fog lights; and tap the switch again to turn off the rear fog lights.

Reading light switch: When it is lit, the reading light switch is turned on; and tap the switch again to turn the reading light off.

Guide Me Home switch: Tap to set the trigger time of Guide Me Home or deactivate this function. When the outside is dark after the Guide Me Home function is activated, the position lamp and low beam headlamps will automatically go on after the vehicle is locked and automatically go off after some time. During the lighting period, if the vehicle is locked again, the position lamps and low beam headlamps will continue to be on for a period of time.



Headlamp leveling: Tap  to enter the headlamp leveling interface, and slide the slider up and down to adjust the headlamp height. Tap the Reset button to restore the set angle of the headlamps when they leave the factory.



Direction indicator lamp: When the vehicle is energized, toggle the light and wiper control switch on the lower left side up and down to turn on the left and the right direction indicator lamps. After the lamp and wiper control switch is returned to the normal position, the direction indicator lamp is turned off.

NOTE

- When the direction indicator lamp on one side fails, it will flash at a double frequency after being turned on.
- When a collision occurs, the left and the right direction indicator lamps flash simultaneously after receiving the collision signal from the airbag module.
- When the hazard warning lamp is on, if the direction indicator lamp switch is operated, the corresponding direction indicator lamp will flash. After the direction indicator lamp is turned off, the hazard warning lamp will continue to flash.

Daytime running lamp: When the position lamps, the low beam headlamps and the high beam headlamps are off, the daytime running lamps will be on after the vehicle is started successfully.

When one of the position lamps, the low beam headlamps and the high beam headlamps are on or the vehicle is locked, the daytime running lamps will be off.

When the direction indicator lamp on one side is turned on, the daytime running lamp on that side will be off.

The intermittent luminous warnings do not affect the daytime running lamps to be on and off.



High beam: When the low beam headlamps are on, press the lamp and wiper control switch in the direction away from the steering wheel as shown by the arrow to turn on the high beam headlamps, and at the same time the high beam indicator lamp on the instrument cluster is on.



Intermittent luminous warnings: When the vehicle is energized, toggle the lamp and wiper control switch towards the direction of the steering wheel to turn on the high beam headlamps. After releasing, the control lever will automatically return to the normal position, and the high beam headlamps will be off. By operating the high beam headlamps to flash, you can let other road participants understand your intention to overtake.

High-mounted stop lamp and stop lamp: As you step on the brake pedal, the high-mounted stop lamp and stop lamp illuminate.

Reversing lamp: When the vehicle is in the "READY" state and in "Reverse" gear, the reversing lamp will be on.

NOTE

- In a humid environment, when the temperature difference is significant, water vapor may appear inside the headlamps and tail lamps. If the water vapor completely or largely disappears after

the lamps are turned on for a short time, it does not mean that the headlamps and tail lamps are faulty.

DRIVING IN SPECIAL WEATHER CONDITIONS

DRIVING IN FOGGY DAYS

PRECAUTIONS FOR DRIVING IN FOGGY DAYS

- When driving in fog, turn on the fog lamps and slow down, honk the horn to alert other pedestrians and vehicles.
- When you hear the horns of other vehicles, you should also honk immediately to signal the position of your vehicle.
- When driving in foggy days, pay attention to controlling the speed of the vehicle, and do not drive at a speed exceeding 100 km/h. Advice when driving on the expressway:
 - When the visibility is at 200~500 m, the vehicle speed shall not exceed 80 km/h.
 - When the visibility is at 100~200 m, the vehicle speed shall not exceed 60 km/h.
 - When the visibility is at 50~100 m, the vehicle speed shall not exceed 40 km/h.
 - When the visibility is within 50 m, the vehicle speed shall not exceed 20 km/h.
- When driving in foggy days, try to drive in the middle of the road instead of driving along the roadside, and avoid collision with vehicles temporarily parked on the roadside.
- Before driving in foggy days, you should thoroughly check the lamps of the vehicle. When driving, turn on the rear fog lamps, position lamps and low beam headlamps, and use the lights to improve visibility, thus seeing clearly the vehicles, pedestrians and road conditions in front, and letting others see your vehicle. Also, do not use high beams when driving in foggy days.
- When driving in foggy days, do not forcefully step on or quickly release the accelerator pedal, and do not brake or turn the

steering wheel sharply. If you have to reduce the speed of the vehicle, first slowly release the accelerator pedal, and then gently step on the brake pedal for several times in succession to control the speed and prevent the occurrence of rear-end collision accidents.

WARNING

- Check the vehicle lighting system before traveling, such as front and rear combination lamps, rear fog lamps, etc., preventing incidents and personal injuries during driving.
- In foggy days, please do not drive. The visibility of driving on roads in foggy days is low, which is prone to traffic incidents, causing personal injury and even endangering lives.

DRIVING IN RAINY DAYS

PRECAUTIONS FOR DRIVING IN RAINY DAYS

- When it rains, the windows are prone to fog due to reduced visibility, and the roads are slippery. Therefore, you should drive cautiously.
- When it starts to rain, you should drive at a low speed because the road becomes slippery.
- When it rains, the exterior rearview mirror shall be cleaned in time to prevent the raindrops accumulated on the rearview mirrors from causing blind spots of the driver's sight.
- In case of cloudy days, heavy rain and fog days with poor visibility, the fog lamps and the low beam headlamps shall be turned on in time.
- When the rain is too heavy or it is impossible to continue driving in case of thunder and lightning, the vehicle shall be parked in a position without water to prevent it from being soaked, and the hazard warning lamp shall be turned on to remind the vehicles behind to pay attention.
- When driving in rainy days, do not forcefully step on or quickly release the accelerator pedal, and do not brake or turn the

steering wheel sharply. When driving in rainy days and if you have to reduce the speed of the vehicle, first slowly release the accelerator pedal, and then gently step on the brake pedal for several times in succession to control the speed and prevent the occurrence of rear-end collision accidents.

- After rainy days, the vehicle shall be cleaned in time to prevent acidic substances in rainwater from corroding the paint surface of the vehicle body.

⚠ WARNING

- When driving in rainy days, please control the speed of the vehicle. In rainy days, the visibility is low, and the road surface is slippery, which is prone to traffic accidents, causing injuries and even endangering lives.

ⓘ ATTENTION

- When performing emergency braking, acceleration, or sharp turning of the steering wheel on slippery roads, the vehicle is prone to slipping and difficult to control. Please drive cautiously.
- Before driving onto road sections with accumulated water, the depth must be checked, and the height of the accumulated water shall not exceed the lower edge of the vehicle body.
- After driving out of the road section with accumulated water, please gently step on the brake pedal to check whether the brake works properly. When the brake pads are wet, the braking performance will be significantly reduced, and accidents are prone to occur.

WIPER CONTROL



Toggle the wiper switch on the lamp and wiper control switch up and down to select the wiper position.

○Reset: The wiper keeps in the initial position and does not move.

•••Intermittent 1: The wiper automatically wipes at a low speed at a long time interval.

•••Intermittent 2: The wiper automatically wipes at a low speed at a relatively short time interval.

—Manual Low position: The wiper operates continuously at a certain frequency and a low speed.

═Manual High position: The wiper operates continuously at a certain frequency and a high speed.

NOTE

- If the surface of the front windshield is dirty or has foreign matters (snow, gum, etc.), the foreign matters shall be removed first, otherwise the wiper blade or the interior structure of the wiper may be damaged.
- Before using the wiper to wipe automatically in winter, make sure that the wiper blades are not frozen on the windshield.
- Before washing the vehicle, make sure that the windshield wiper is in the off position.

FRONT WINDSHIELD WASHING

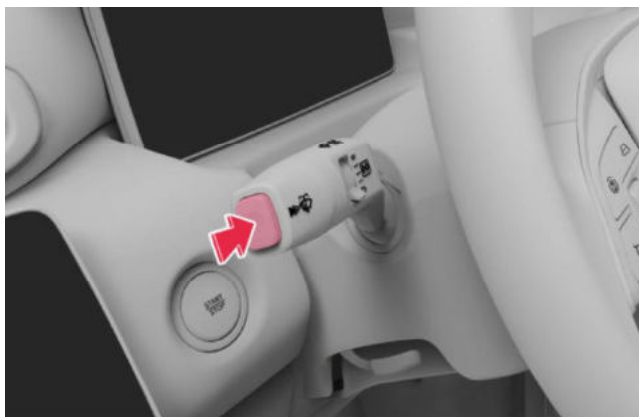

When the vehicle is energized, short press the washer switch button on the top of the lamp and wiper control switch to turn on the function of merely wiping, and the front washer is inoperative.

Press and hold the washer switch button, the front washer sprays washer fluid, and the wiper wipes three times at a low

speed. After a few seconds, it wipes again once and stops moving.

ATTENTION

- When the windshield is dry or the washer fluid in the washer fluid reservoir is exhausted, do not use the wiper blades.

REARVIEW MIRROR HEATING

When driving in rainy days, water droplets are likely to remain in the side mirrors, which will block the driver's vision and affect driving safety. The rearview mirror heating function can heat the side mirror glass to evaporate the water droplets and keep the side mirror clear.

In the Vehicle Control - Quick Control interface on the Infotainment Screen, you can tap the rearview mirror heating icon to turn on the rearview mirror heating function, and tap the rearview mirror heating icon again during heating to turn off the heating function.

ATTENTION

- During the heating of side mirrors, do not touch the glass of the side mirrors with hands to avoid burns.

DRIVING IN HOT SEASONS

When driving in hot weather such as summer, please observe the precautions for driving in hot seasons to ensure the safety of others and yourself.

ATTENTION

- Do not expose the vehicle for a long time in hot summer, and do not place flammable items (such as lighters, paper scraps, cloth toys, etc.) in and near the instrument panel of the vehicle.

In summer, the ambient temperature is high, and the vehicle is prone to overheating. Therefore, in summer, the inspection and maintenance of the vehicle cooling system shall be strengthened, and water scale in the coolant expansion tank and the water channel as well as sundries in the radiator chip shall be removed in time.

WARNING

- Do not drive the vehicle wearing slippers or high heels.

ATTENTION

- Since the weather is hot in summer, it is necessary to check whether the vehicle lines are short-circuited or aged, whether the plugs are loose, whether the battery is in normal working condition, etc., to prevent the vehicle from spontaneous combustion.
 - In summer, the tire pressure in the wheel tire will increase with the increase of temperature, which is prone to tire burst. When the TPMS indicator  in the instrument lights up during driving, stop the vehicle immediately and wait for the tire temperature to drop before driving.

DRIVING IN COLD SEASONS

When driving in cold weather, please observe the precautions for driving in cold seasons to ensure the safety of others and yourself.

WARNING

- The driving environment in winter is more dangerous than that in other seasons. When driving, you need to be extremely cautious, and you should reduce the speed to avoid incidents, injuries and even life endangering.

Precautions for driving in cold seasons:

- Before driving in winter or other cold seasons, it is essential to carefully check the safety devices in the vehicle, such as the steering, brakes, lamps, instrument cluster, horn, wipers, etc.
- The road is slippery after snow in winter, please keep a steady speed when driving, and do not perform unstable operations such as sudden acceleration, emergency braking, sudden steering, etc.
- Be gentle and slow when starting and accelerating to prevent tire slipping and side-slipping.

Precautions for parking in cold seasons:

- Do not park the vehicle in snow or water to prevent the water from freezing and tearing the tires.
- Place wooden boards at the tires to prevent snow accumulation.
- Do not park the vehicle under a tree to prevent the falling ice from damaging the vehicle.
- When parking, the wiper arm can be raised to prevent freezing on the windshield glass, and avoid tearing of the wiper blade or damage to the wiper motor during use.
- Wipe off the snow water on the combination lamp to prevent it from freezing and cracking the combination lamp.
- Try to choose a level ground for parking.
- When parking, open the door to cool down, and lock the door after a few minutes. Reduce the temperature difference between the inside and the outside of the vehicle to prevent the glass from freezing.

In cold weathers, the energy of any battery will drop, so the condition of the battery shall be checked frequently to keep sufficient battery energy for starting.

In winter, please use the glass washing fluid containing anti-freezing agent.

You are recommended to prepare some equipment and tools in case of emergency. It is recommended to carry the following supplies: tire chains, window scrapers, signal flash devices, connecting cables, etc.

Use of tire chains:

- When driving in harsh environments such as snow or icy roads in winter, tire chains can be installed.
- Different countries or regions have different laws and regulations on tire chains. Before assembling the tire chains, you should refer to the laws and regulations of each country or region. The installation of tire chains shall be avoided when you do not know whether the use of tire chains is restricted by regulations in some countries or regions.
- Tire chains shall be installed in pairs on the front tires, not on the rear tires.
- Do not use tire chains on dry roads. After driving on a snow-free road, please remove the tire chains.
- After installing the tire chains on the tires, you should bear in mind that the power of the vehicle may be insufficient. Drive cautiously even if the road surface is in good condition. Do not drive above the speed limit for tire chains or 50km/h, whichever is lower.
- Install the tire chains as closely as possible to the front tires, and after driving for 0.5-1.0km (0.311-0.621mi), tighten the chains again.
- Wrong specifications of the tire chains will adversely affect the performance and safety of the vehicle. Moreover, driving laden, speeding, emergency acceleration, emergency braking,

emergency turning and other operations are potentially dangerous.

- When decelerating, make full use of the braking performance. Emergency braking on roads with snow or ice will lead to drift and slip. Keep a proper safe distance from the vehicle in front, and step on the brake pedal slightly. The tire chains installed on the tires can provide certain friction, but they cannot prevent side-slipping.
- Drive cautiously and avoid road bumps, holes and sharp turns or wheel lock, as they may adversely affect the vehicle.

EVENT DATA RECORDER

The vehicle is equipped with an event data recorder (EDR) system. Depending on the type and severity of collision, the EDR system may record the following data information regarding dynamic stability control system and safety system during vehicle collision (including but not limited to):

- Brake pedal/accelerator pedal positions.
- Vehicle speed (the speed is the wheel speed, which is indicated by the wheel speed sensor).
- Longitudinal acceleration of vehicle.
- Seat belt locking status.

The above data can be used to restore the vehicle state at the time of the accident and assist with the analysis.

Due to the limited storage space for EDR data, the system divides the saved events into overridable events and non-overridable events:

- Overridable events refer to similar accident scenarios where data for such events may be overwritten when there is insufficient storage space. For example, data saved when a

collision event occurs but the airbag trigger threshold is not reached.

- Events that cannot be overwritten will be continuously stored in the EDR. For example, the data saved during the point enabling of the airbag or seat belt pre-tensioner.

We will not disclose the data to third parties except in the following circumstances:

- Reach an agreement with the owner (or the lessee of the vehicle).
- At the official request of the police, court or government agency.
- It is only used for the technical diagnosis, research and development of the vehicle by Leapmotor, and the owner information or identity information will not be disclosed.

The way to obtain the EDR data:

- Special technical equipment is needed to read the EDR data. If you want to read the EDR data or know about more information, please contact the authorized dealer.

PARKING



PARKING SETTINGS

REVERSING ASSIST SYSTEM

REVERSING RADAR SYSTEM

The reversing radar system can assist the driver to park the vehicle and adjust the vehicle position.

Before the reversing radar system is enabled, the radar sensor on the rear bumper sends and receives ultrasonic waves, and the system calculates the distance from the rear of the vehicle to an obstacle, if there is, based on the ultrasonic waves sent and reflected.

Enable the reversing radar system: Engage Reverse when the vehicle is at the READY state, and then the reversing radar begins its working state and the vehicle sends out chime sounds based on the distances to front and rear obstacles and displays the radar detected information on the instrument cluster.

Phased warnings and displays of reversing radar system:

Distance	Image displayed	Text displayed	Alarm sound
0~0.3m	Red	Stop	Quick chiming
0.3~0.8m	Orange	Distance value	Slow chiming
0.8~1.5m	Yellow	N/A	N/A

The reversing radar system may give a false warning or not warn under the following conditions:

- When there are thin obstacles, such as steel wires, ropes, wire fence, etc.
- When the vehicle is driving or parked on rough road or in the brushes.
- When the radio or antenna at high frequency output is installed and used.
- When there are shorter objects like rocks.
- When there is an object that easily absorb ultrasonic waves, such as loose snow, cotton, sponge, etc.
- When the horn sound of other vehicles, the engine sound of a motorcycle or brake sounds with gas emission, etc. are close.
- When a foreign matter is stuck on the radar sensor.
- When water drops are splashed or ice is covered on the radar sensor.
- When the radar sensor is covered up in any way.
- When the vehicle is driven in heavy rain or snow.
- Disturbance of metal striking sound.
- Within an environment of same frequency.
- When the vehicle inclines to one side obviously or is excessively overloaded.
- When the vehicle is driven on a very bumpy road, a slope, gravel pavement or grasslands.
- When the radar sensor is repainted.
- When the bumper or the radar sensor is heavily impacted.
- When the vehicle is approaching a high or curved curb.
- When the sun is burning or it is frosty.
- When a non-OEM suspension with quality inferior to OEM ones is installed.

The above examples do not cover all the conditions that affect the normal operation of the reversing radar system. It is possible that the radar sensor cannot correctly determine the actual distance to some objects due to their own shape.

 **WARNING**

- The radar is unable to work normally under all driving, traffic, weather and road conditions. When the surrounding environment is complicated or of poor conditions, you should drive carefully and be always responsible for driving safety.
- The radar sensor cannot replace the driver's observation of the surrounding environment. The driver should concentrate on reversing safely and adjusting the parking space according to the actual situation.
- There are blind spots when the radar sensor detects obstacles. During reversing, The driver should always be alert to the surrounding environment and bear full responsibility for vehicle safety.
- The shape and material of obstacles may hinder the radar to detect them.

! ATTENTION

- Always keep the surface of the reversing radar sensor clean, and do not cover the sensor.
- To ensure the functions of the reversing radar sensor, it shall be maintained clean and kept from icing.
- When cleaning the surface of the reversing radar sensor, a soft damp cloth should be used to avoid scratching the surface.
- Please don't flush the position of the radar sensor with water or steam, otherwise the radar may malfunction.
- When the reversing radar sensor is damaged, don't replace or repair it by yourself. It is recommended to contact an authorized dealer for check and repair in time.
- To avoid the function of the radar sensor from being affected, you should not paint or install an enclosure over the rear bumpers.
- The rear license plates shall not be framed or installed with other objects to avoid interfering the radar sensor.
- If an image is shown on the instrument cluster or the buzzer sounds, an obstacle may be detected by the radar, or the radar is

interfered by the external environment. If the situation continues, maintenance at the authorized dealer is suggested.

- If the reversing radar system fails, the driving assist system fault warning indicator  on the instrument cluster will always be on. Please contact the authorized dealer for maintenance in time.

RVC

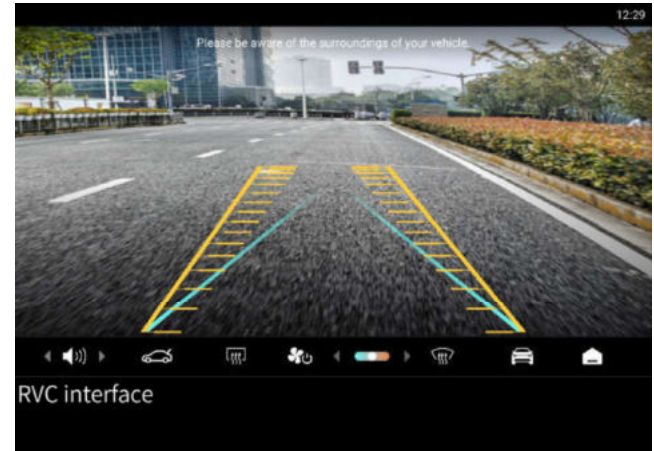

The rear-view camera (RVC) system can display real-time images behind the vehicle on the Infotainment Screen through the rear view camera installed beside the license plate lamp to enable the driver comprehensively master different complicated road conditions behind the vehicle and improve the safety in reversing.

Operating conditions of RVC: Engage the Reverse gear when the vehicle is at the READY state, and then the RVC system automatically starts the working mode; when R is disengaged, the reversing screen is closed.

⚠ WARNING

- As the rear view camera has blind spots, you must look out surrounding children or pets, if any, during reversing. The rear view camera may also be unable to identify upright objects at higher positions, such as wall protrusions.
- The RVC system cannot substitute the observation of surroundings made by the driver, and the driver should always be alert to the surrounding environment and bear full responsibility for vehicle safety.
- The object distance displayed on the RVC interface may be different from your subjective feeling, especially when the object is close to the vehicle. The driver should judge the distance between the vehicle and the object through a variety of means.
- When HP water is used to wash the vehicle body, maximally avoid directly flush on the camera to prevent the operation performance of the camera from being affected. If there is water or dust on the camera, wipe it clean with soft wet cloth in time.
- Don't knock the camera in any way, otherwise it may malfunction or be damaged.
- If the IVI system is not completely booted after the vehicle is started, the RVC display interface would be subject to a time delay or flash if you engage the Reversing (R) gear at this moment. This is the power-on process during starting of the camera and a normal phenomenon.

ELECTRONIC PARKING BRAKE (EPB)

The driver can apply or release the parking brake by operating the EPB button. When starting on a slope, you can use the HSA; As you step on the accelerator pedal, the EPB will automatically release, providing convenient driving assistance for the driver.

ⓘ NOTE

- The EPB system parks the vehicle with a constant force based on gradients, and if the vehicle slides downward after it is parked on a slope, the EPB system would automatically increase the braking force.

APPLICATION OF ELECTRONIC PARKING BRAKE

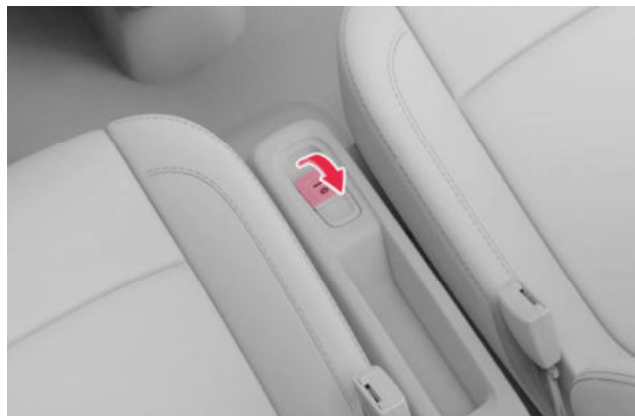

When the vehicle is stationary, as you pull up the EPB button, the button indicator lamp will be on. The EPB indicator lamp  on the instrument cluster will be on, indicating that the EPB has been activated.

⚠ WARNING

- Don't reduce the vehicle speed with the EPB under unnecessary conditions during driving, as the EPB only applies the braking force to the rear wheels, liable to cause a traffic incident.

NOTE

- Motor running sounds are produced when the EPB is applied. This is normal.
- To park, the EPB must be applied.
- If the vehicle slides downward a slope after the brake is applied, step on the brake pedal to brake and drive the vehicle to a level road for parking. Please contact an authorized dealer for check and repair in time.
- When parking on a slope, it is recommended to place wheel chocks or other hard objects to prevent the vehicle from sliding down the slope when leaving the vehicle, to avoid sliding down the slope due to long-term parking.

RELEASE OF ELECTRONIC PARKING BRAKE





When the vehicle is powered on, step on the brake pedal and press the EPB button. The switch indicator lamp goes out, and the EPB indicator lamp  in the instrument cluster goes out, indicating that the EPB has been released.

NOTE

- Motor running sounds are produced when the EPB is released. This is normal.
- If the EPB is not used for a long time, the system would detect automatically, and motor running sounds can be heard.

Dynamic emergency braking: If the service brake fails when you are driving, keep pulling up the EPB switch to realize emergency braking. Release the EPB switch or step down the accelerator pedal, and then the system exits the emergency braking mode.

In case of any of the following conditions, operate the EPB switch once again; if the fault symptom still exists, please contact an authorized dealer for check and repair.

- If the EPB indicator lamp  flashes continuously, it indicates that the EPB is partially engaged/released or there is a system fault.
- If the EPB indicator  lights up without applying the EPB, it indicates that the system is abnormal.
- If the EPB fault warning lamp  lights up, it indicates that the performance level of the EPB is decreased.

WARNING

- Do not use dynamic emergency braking unless necessary; otherwise it will easily lead to traffic incidents and shorten the service life of parking brake system.

LEAVE THE VEHICLE



Leave the vehicle

PREPARATIONS

CLOSING WINDOWS

Refer to the [Window control](#) (page 64) section for closing the windows in the vehicle.

POWERING OFF

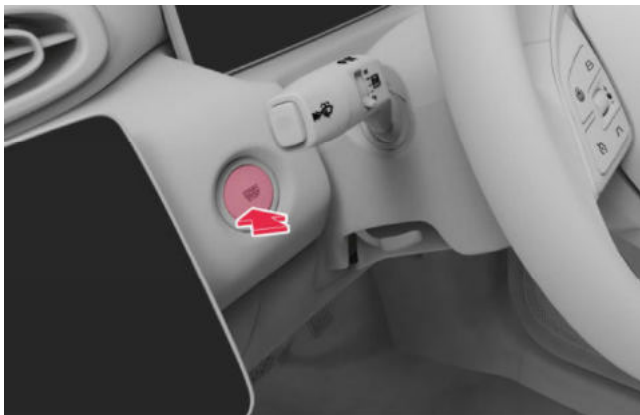

After parking, the start/stop button to switch the vehicle power system to the ON1 state, and then power it off by locking the vehicle from outside.

NOTE

- Please make sure that the vehicle is powered off before leaving the vehicle.

UNLOCK IN VEHICLE

CENTRAL CONTROL UNLOCKING



When all doors are locked, press the Unlock key on the center control door lock to simultaneously unlock all the doors.

INTERIOR HANDLE UNLOCKING



Pull the interior door handle in the direct as shown in the figure:

- When the vehicle is locked, pull the interior door handle for the first time to unlock the current door, and pull it again to open the current door.
- When the vehicle is unlocked, pull the interior door handle to open the current door.

⚠ WARNING

- Don't pull any interior door handle during driving.

ⓘ ATTENTION

- After the child locks are turned on, the rear doors cannot be opened from the interior.

- Don't overexert when pulling the door's interior handle to prevent damaging the vehicle.

AFTER LEAVING THE VEHICLE

SAFETY TIPS FOR LEAVING THE VEHICLE

When you want to lock the vehicle after getting off while the driver door is not closed, the vehicle cannot be locked, the instrument cluster indicates door left open and gives text prompts.

ⓘ ATTENTION

- When leaving the vehicle, please confirm if the doors are closed and vehicle is locked.

Leave the vehicle

LOCKING

LOCKING THE VEHICLE

LOCKING WITH KEY FOB



When all the doors are closed, press the Lock key on the key fob to lock the vehicle, and all the direction indicator lamps flash once.

NOTE

- When leaving the vehicle, do remember to take along the key fob, otherwise it is possible that the vehicle cannot be locked.
- Don't put the key fob in the rear trunk. It may be incidentally locked in the vehicle.

EXTERIOR REARVIEW MIRROR FOLDING

EXTERIOR REARVIEW MIRROR FOLDING

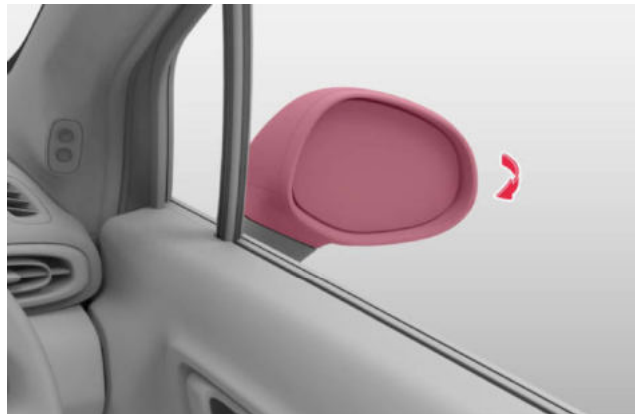

When necessary, the side mirrors can be folded manually. Push the side mirror towards the rear of the vehicle to fold the mirror.

WARNING

- Before setting out, do remember to unfold the folded rearview mirrors to ensure the driving safety.

WALKING AWAY



WALKING AWAY

GUIDE ME HOME

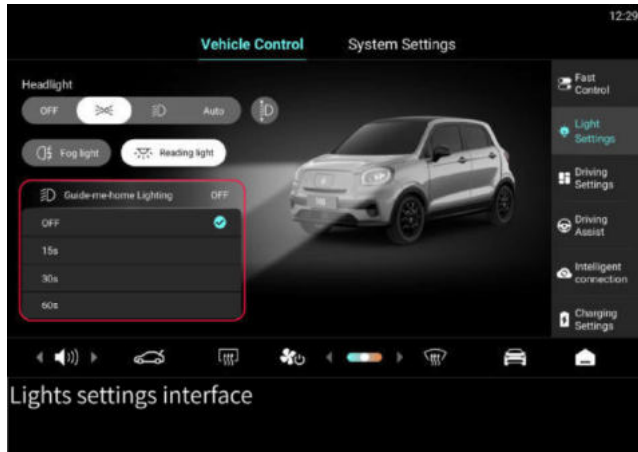

After the Guide Me Home function is disabled on the Infotainment Screen, the position lamp and the low beam headlamps do not go on after the vehicle is closed and locked.

The Guide Me Home function can be set on the Vehicle Control - Lamp Settings interface on the Infotainment Screen. Touch the Guide Me Home setting frame to select the prolonged time or disable the function.

When the outside is dark after the Guide Me Home function is activated, the position lamp and low beam headlamps will automatically go on after the vehicle is locked and automatically go off after some time. During the lighting period, if the vehicle is locked again, the position lamps and low beam headlamps will continue to be on for a period of time.

MAINTENANCE AND CLEANING



VEHICLE CLEANING

EXTERIOR CLEANING

Wash your vehicle regularly to help protect the appearance of your vehicle. Please wash the vehicle with the regular washing methods.

The following conditions will cause the peeling of the paint or lead to corrosion of the body and parts, and the vehicle must be cleaned immediately:

- After the vehicle is driven in a coastal area for some time.
- After the vehicle is driven on pavement with coal tar, resin, bird manure and dead insects for some time.
- After the vehicle is driven in an area with large amounts of soot, coal ash, dust, iron filing or chemical materials for some time.
- When the vehicle is apparently smeared by dust and mud.

MANUAL WASHING

Park the vehicle at a shaded place, and wash the vehicle after it sufficiently cools down.

1. Flush off the loose dirt and all mud or saline-alkaline matters from roads that are at the bottom or in recessed parts of the wheels of the vehicle through a hose.
2. Soak special washing agent in a sponge bar, and gently wipe off dirt with the sponge.
3. Clean the tires with tire dedicated cleaning sponge and a brush.
4. Sufficiently flush the vehicle.
5. To prevent water stains on the body, use special absorbent towels to dry the body. Do not wipe or press hard, otherwise the paint may be damaged.

WARNING

- When washing the chassis, take care not to cut your fingers.
- Don't wash the vehicle while charging.
- Don't flush the high voltage devices at the bottom of the vehicle to avoid electric shock or vehicle damage.

ATTENTION

- When washing and waxing the vehicle, please choose special cleaning agents and curing agents, pay attention to the shelf life before use, and be sure to store them in a place out of reach of children after use.
- Don't wash the vehicle in direct sunlight, or you will risk damaging the paint.
- To wash the vehicle in winter, if you use flush the vehicle through a hose, please note that the spray of water should not be directed at the exterior door handles, the charging port and the door joints, otherwise these places will be subject to risks of being frozen.
- Don't use rough sponges or corrosive cleaning agents to clean the vehicle to avoid damaging the paint finish.
- The temperature of washing water should not exceed 60°C.
- The charging port plate should be kept closed during the washing process to avoid damaging the vehicle.
- When washing the vehicle with HP water, an excessively high water pressure would damage the paint of the vehicle.
- Don't spray water into the front trunk to avoid short circuits of the electrical parts.
- Don't use highly alkaline laundry detergent, soapy water, dewaxing detergent, organic matters (gasoline, kerosene, volatile oil or strong solvent).
- Do not wipe the lamps with dry towels or use abrasive cleaning agent to clean the lamps to avoid scratching them.
- Don't wax the surface of lamps to avoid damaging the lamps. Alcohol or organic detergents (such as adhesive remover, tar

cleaner, coating, foam cleaner, iron dust cleaner for paint finish, glass cleaner, thinner, deicing agent, paint treatment agent, etc.) may damage the lamps and cause cracking. Protect the lamps during vehicle washing or during the installation of protective films.

- Don't wipe the body with abrasive cleaner.
- Wax the plated bright metal parts on a regular basis for protection.

AUTOMATIC WASHING

When washing the vehicle at an automated carwash, be aware that certain types of brushes, unfiltered washing water or machine-defined washing procedures may scratch the paint finish. Scratches on the paint finish would reduce the durability and gloss of the finish, especially on dark-colored vehicles.

It is best to consult the staff of the carwash before washing the vehicle to choose the safest washing procedure for the paint finish of your vehicle.

ECO

- The vehicle should be washed at a professional carwash, which can treat the sewage correctly to avoid polluting the environment.

INTERIOR CLEANING

To clean the interior of the vehicle, please read the following tips first.

WARNING

- Don't damp the airbag components or wires in the vehicle, otherwise the airbag may not be deployed or incidentally explode, resulting in serious injury and even endangering life.

- Don't use polishing wax or polishing detergent, otherwise the instrument panel may reflect light onto the windshield, blocking the driver's field of view, causing serious injury and even endangering life.

ATTENTION

- Don't spill liquids such as cleaners into the vehicle, otherwise electrical components may malfunction due to dampness. In case of incidental splashes, quickly wipe away all spilled liquids.
- To use a cleaner, please carefully read the instructions for using the cleaner and strictly abide by them. Avoid using organic substances (solvents, kerosene, alcohol and gasoline) or acid-base solutions, as these chemicals will cause discoloration, contamination or peeling of the surface.
- Colored clothing of certain materials (such as dark jeans and sheepskin clothing) may stain the interior fabric. If this happens, it is important to clean and maintain the fabric in these areas as soon as possible.
- Do not spray detergent directly onto components with electrical buttons and controls. Wipe them with soft clothes dipped with cleaning agent.
- Sharp objects may damage fabric facing.
- Don't use solvent-based cleaning agents to clean the instrument panel, the trim cover of airbags, or leather products.
- Don't spray water in the vehicle to avoid short circuits of the electrical parts.

CLEANING INSTRUMENT PANEL AND OTHER INTERIOR PARTS

The following precautions should be taken for cleaning the instrument panel and other interior parts:

- For cleaning the instrument panel, soak a clean soft cloth in warm water, and then gently wipe away the dust.

Maintenance and Cleaning

- Don't remove dirt from the interior surface with a blade or other sharp objects.
- Don't use a stiff brush, which may damage the interior surface of the vehicle.
- Do not use excessive force or press to wipe the interior. Excessive force will not only fail to achieve the descaling effect, but also damage the interior.
- Try to use mild neutral soaps and avoid using strong detergents or degreasing soaps.
- Do not soak the interior during cleaning.

ⓘ ATTENTION

- Don't use polishing wax or cleaning agent on the surface of the instrument cluster or other interior parts to avoid damaging the surface of the parts.

CLEAN LEATHER

If the vehicle leather trim is not maintained and cleaned for a long time, it can lead to moisture, mildew, lusterlessness, dry cracking, and aging of the leather, affecting the health and the driving experience. Therefore, vehicle leather must be used and cured thoroughly and meticulously with the following methods:

- Use a semi-dry cloth to remove dust from leather trims, but if more thorough cleaning is required, use a special leather cleaner. After cleaning, wipe leather trims with a dry cloth or keep the leather dry naturally.
- Don't use ordinary detergents (laundry detergent and detergent) to clean leather, otherwise the leather surface will be corroded or discolored.

ⓘ ATTENTION

- Avoid exposing the vehicle to strong sunlight for a long time to prevent fading of the leather material. If you need to park your vehicle outdoors for an extended period of time, cover the leather areas.
- Sharp objects at the edges of clothing may leave scratches on the surface of the leather material.
- Don't apply sunscreen, hand cream and similar products on the leather surfaces.
- Don't place sharp objects on the seats, such as keys, scissors, etc., to avoid scratching or cutting the leather.
- Don't use alcoholic, corrosive, acidic or alkaline curing agents, which damage the protective layer over the leather surface.
- Don't use a hair dryer to blow the leather surface. Improper temperature control will cause the leather to shrink. Wipe the surface and dry it naturally.
- Do not place vinyl, plastic or waxy products on the surface of leather interior. Because when the temperature inside the vehicle rises significantly, these products may stick to the leather.

SWITCH CLEANING

-Use a small soft bristle brush to flick away the dust on the key and switch.

WINDOW CLEANING

Use soft cloth and special glass cleaner to clean the glass surfaces of the vehicle. Don't use any abrasive cleaning fluid, otherwise the glass may be scratched or the defogging function of the rear window may be damaged.

ⓘ ATTENTION

- When cleaning the interior side of the rear windscreen, be careful to avoid scratching or damaging the electrical heating wires and the connector.

SEAT BELT CLEANING

Clean seat belts with a sponge or soft cloth dipped in neutral soapy water or warm water. Please check the seat belts for excessive wearing and scratches on a regular basis.

ⓘ ATTENTION

- Don't retract the seat belts until they are completely dry; otherwise, the seat belt retractors would be damaged.
- Don't use bleach, dye, or cleaning solvents, which can reduce the durability of the seat belts.

CLEANING CARPETS

Please clean the carpet as follows:

- Carpets should be cleaned with a high-quality foam cleaner.
- First, remove dust with a vacuum cleaner as much as possible, and then scrub the carpet by drawing circles with a sponge or brush soaked with foam.
- Don't use clean water to avoid body corrosion caused by water immersion. Please keep the carpet dry.

VEHICLE MAINTENANCE

EXTERIOR MAINTENANCE

VEHICLE WAXING

In order to keep the vehicle polished as a new one, we recommend you to polish and wax the surface of the body once a month or when the surface does not properly resist water.

- Make sure to wash and wipe your vehicle dry before waxing, even if you use a combination of detergent and car wax.

- Use quality polishing agent and car wax. If the polished surface of the body is heavily weathered, use a car cleaning polish without car wax. Carefully follow the instructions and precautions given by the manufacturer. Polish and wax chrome and painted surface as well.
- When the body surface is in contact with water on a large scale, no water droplets come into being and the water remains on the body surface, the vehicle should be waxed again.

MAINTENANCE OF PAINT FINISH

Pay attention to the following points during maintenance of the paint finish of the vehicle:

- Timely wash the vehicle after raining. Rain stains on the body will gradually shrink after raining and the concentrations of acidic substances in the rain will gradually increase. If rain stains are not rinsed with water as soon as possible, the paint finish would be damaged over time.
- When washing the vehicle, use special detergent and neutral running water, and don't use highly alkaline washing powder, soapy water or dishwashing liquid, to prevent washing off the grease in the paint finish, accelerating the aging of the finish. If the vehicle is washed in a carwash, remind the washing personnel not to use dewaxing detergent to avoid damaging the paint finish. In particular, vehicles running in coastal or heavily polluted areas should be rinsed on a daily basis.
- Use clean and soft cloth or sponge to wipe the vehicle to prevent metal and sand particles. Do not use any dry cloth, towel or sponge to wipe the vehicle to leave no scratches. When wiping, gently wipe along the direction of the water flow, instead of in circles or crosswise.
- Some special and highly corrosive traces (e.g., asphalt, bird droppings, or insects) shall be removed in a timely manner. It must be cleaned with special detergent, and cannot be scraped with a knife or removed with gasoline to avoid damaging the paint finish.

Maintenance and Cleaning

- Don't touch the body paint finish with your hands stained by oil or wipe the paint finish with oil stained rags, and do not put any tool with oil stains or rags with organic solvents on the body to prevent chemical reactions.
- If there is no obvious scratch on the paint finish, don't paint the vehicle again with a wet finger to prevent mismatch of paint colors or poor combination.
- Avoid strong impacts, collisions and scratches on the paint finish of the body. In case of any scratch, pit or peeling of the paint finish, touch up in time. It is suggested to touch up in the authorized dealer.
- Wax the plated bright metal parts on a regular basis for protection.
- Use a detergent of good quality to clean the body trimmings, and don't scrub hard during waxing to prevent penetrating the paint finish.
- Wax the paint finish from time to time for protection, and regularly (quarterly) drive your vehicle to the authorized dealer for maintenance to restore the bright gloss of the paint finish of the body in time.

INTERIOR MAINTENANCE

Interior maintenance is based on cleaning inside the vehicle. After completion of cleaning inside the vehicle, conduct the interior maintenance in the following ways.

- After cleaning of the instrument panel, a layer of clean and protective water wax can be applied on the instrument panel to mitigate the aging of the instrument panel and other plastic parts, thus to prolong the service life of the plastic material.
- Leather trims can be sprayed with special leather wax and then polished with a dry cloth.
- For the window glasses, etc., glass coating products can be sprayed on them to prevent fogging of the windows during rainy and snowy days or when driving in winter.

- The sealing strip of an automobile has the sealing action due to its colloidal properties. The sealing strip should be regularly maintained with a rubber maintenance agent to ensure that the sealing strip remains elastic for a long time.

TIRE MAINTENANCE

For the sake of safety, the type and size of tires must be suitable for your vehicle model, while all tires have good tread patterns and standard tire pressures.

TIRE PRESSURE

The proper tire pressure can improve vehicle maneuverability and driving comfort, and is beneficial to extending the service life of tire treads.

The vehicle is equipped with a tire pressure monitoring device (direct). In the cold tire state, check the tire pressure values on the Vehicle Control - Health interface of the Infotainment Screen to determine whether it is necessary to increase the tire pressure.

Cold tire status: The vehicle has parked for at least 3 hours or run for no more than 1.6km (0.994mi).

ATTENTION

- Using tires with insufficient tire pressure will lead to uneven tire wear, affect vehicle maneuverability and power consumption, and cause air leakage due to overheating, and even loss of control of the vehicle in severe cases.
- Tires with high tire pressure will reduce the comfort of the vehicle, and are more likely to be damaged due to uneven road surfaces. In severe cases, there is a risk of tire burst, which seriously threatens the safety of the entire vehicle. Moreover, it

will also lead to uneven tire wear and shorten the service life of tires.

TIRE INSPECTION

Every time when you check the tire pressures, also check the tires for apparent damage, penetration by foreign matters, and wearing status. A tire should be replaced under the following circumstances:

- Damages and bulges on the tread or side. If either condition is found, the tire should be replaced.
- Scratches, cracks, or fractures on the side of the tire. If the tire fabric or cord thread is visible, replace the tire.
- Excessive tread wear.

TIRE MAINTENANCE

Satisfactory tire pressures and good driving habits will extend the service life of the tires.

- Periodically check the tire pressure.
- Check the tire condition regularly, and check the wearing status irregularly.
- Be careful to avoid the tires from being stained by oil.
- Don't turn or accelerate abruptly.
- Every wheel must be re-balanced after new tires are installed or after tire repair.

CHANGING TIRES AND WHEELS

The original tires of this vehicle are selected to maximize vehicle performance, while providing you with the best combination of maneuverability, ride comfort and service life.

You are recommended to purchase original tires from the authorized dealer.

Replacing original tires with radial tires with different sizes, load ranges, rated speeds and maximum cold inflation pressure (marked on the side of the tire), or mixed use of radial and bias tires will reduce the vehicle's braking capacity, driving force (ground adhesion), and steering accuracy.

Unsuitable tires will affect the operational flexibility and stability of the vehicle, and may lead to accidents, resulting in casualties.

It is best to change all four tires at the same time, and if it is not possible or necessary, the two front or rear tires should be changed in pairs. Changing only one tire can seriously affect the maneuverability of the vehicle.

The anti-lock braking system (ABS) works by comparing the speed of the wheels. Therefore, when changing tires, tires to be used must be the same size as the original tires of the vehicle.

NOTE

- Don't use any two types of radial tires, bias belted tires and diagonal-ply tires at the same time, otherwise you will lose control of the vehicle.
- Don't use tires of other sizes than those recommended by Leapmotor.

WINTER TIRE

The vehicle is equipped with summer tires, which may experience reduced performance and traction in low-temperature environments, while also exhibiting increased sensitivity to impact damage. In cold weather, high-performance tires may temporarily harden, resulting in rotational noise during the initial few kilometers before the tires warm up. For optimal vehicle performance, it is recommended to use winter tires in winter. Please select appropriate models of winter tires or studded tires according to local laws and regulations.

Maintenance and Cleaning

It is recommended to fit winter tires for vehicles when driving at a temperature below 7°C. The driving performance of summer tires decreases at low temperatures, reducing comfort. For example, there may be tire-induced shaking noises when maneuvering or accelerating out of bends on dry and wet slippery surfaces.

Extremely low temperature below -15°C may cause permanent damage to summer tires.

WIPER

WIPER MAINTENANCE

When replacing a wiper blade, you should enable the Wiper Maintenance Position. When the vehicle is stationary and the front wipers are not engaged, you can enable the Wiper Maintenance function on the Vehicle Control - Maintenance interface on the Infotainment Screen and set the front windshield wiper blades to the Maintenance Position.

After you have completed the inspection and replacement, please reset the wiper blade. Turn off wiper maintenance on the Infotainment Screen, and the wiper blade will wipe from the maintenance position once and then stop at the initial position.

NOTE

- Wiper maintenance cannot be enabled when the vehicle is not powered on or the instrument cluster is "READY".

REPLACING WIPER BLADES

1. Enable the Wiper Maintenance Position.
2. Lift the wiper arm to be replaced.

ATTENTION

- Don't open the hood when the wiper arm is lifted up; otherwise, the hood and the wiper arm would be damaged.

3. Press the fixing clip on the wiper blade while sliding the blade down the arm.

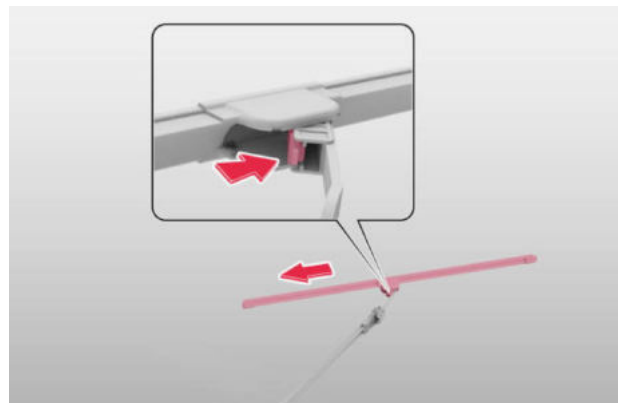

4. Push the new wiper blade hard in the direction shown in the figure until a "click" sound is made.

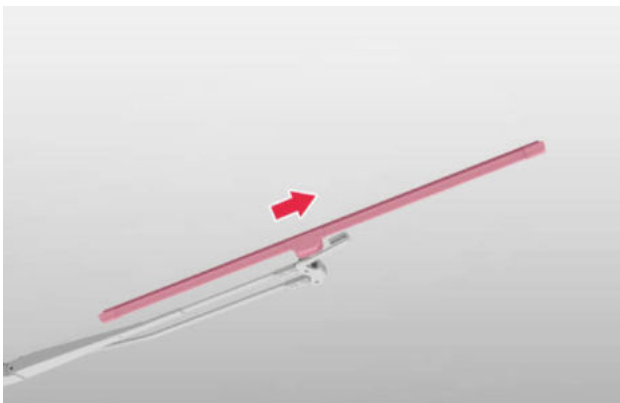

5. Reset the wiper arm to the front windshield.
6. Turn the Wiper Maintenance Mode off on the Infotainment Screen to return the wipers to their normal position.

! ATTENTION

- After the wiper blade is replaced, place the wiper arm slowly on the front windshield with your hand to avoid it from dropping too fast and damaging the front windshield.
- Don't make the wipers come into contact with gasoline, kerosene, paint thinner or other solvents to avoid damages.
- Don't shake the wiper arms to avoid damaging the arms and other parts.
- The wipers cannot be used if the Wiper Maintenance Mode is not turned off on the Infotainment Screen.

BULBS

BULB INSPECTION

Regularly check the operation of external lamps. Damaged bulbs can seriously affect driving safety by reducing the visibility of the vehicle and its ability to signal alerts to other road participants.

REPLACING BULBS

Bulbs should be replaced by a professional. Please contact the authorized dealer for replacement.

! WARNING

- Bulbs are pressurized and may explode when replaced, causing personal injury.
- Modifications or additions to external lamps and signaling devices are prohibited.

FOGGING OF HEADLAMPS

Under certain humid conditions (such as high air humidity, after washing, etc.), a layer of fog or even a small amount of water droplets may cover the headlamp cover, due to the difference in temperature between the interior of the headlamps and the outside air, similar to fogging of the windows on a rainy day, which is a normal physical phenomenon and will not affect the function or the life of the headlamps.

! ATTENTION

- If a large amount of water beads or accumulates inside the cover, please contact an authorized dealer for check and repair.

BRAKE WEAR

The brake friction lining of this vehicle is fitted with wear indicators. The indicator is a thin metal plate attached to the brake friction lining. When the friction lining is worn to the limit, a sharp sound is emitted, indicating that the friction lining has reached the end of their service life and needs to be replaced. It is recommended to contact the authorized dealer to replace the friction lining.

Please refer to the [Technical parameters of brake system](#) (page 238) for specific restrictions on the use of brake friction lining.

WARNING

- Please replace the brake friction lining promptly. Failure to replace the worn friction lining can damage the braking system, leading to brake failure.

NOTE

- Regularly remove the tires and hubs to visually inspect the brakes.
- For areas where road salt is used in winter, it is recommended to clean and lubricate the brake caliper once a year or every 20,000 kilometers.

CORROSION PROTECTION MEASURES

Proper vehicle maintenance can prevent corrosion of the vehicle for a long time. To prevent corrosion of the vehicle, observe the following rules:

- Wash the vehicle regularly. Regular washing keeps the vehicle body clean and prevents corrosion.

- High-pressure washer cannons are very effective for cleaning the chassis and wheel houses of the vehicle. Because it is difficult to see all the mud and dirt in these parts, special attention should be paid to them. Simply wetting the mud and debris without removing it will create a greater hazard. Do not allow dust to clog the drain holes at the lower edge of the doors, the door sill protectors and various parts of the frame, otherwise water in these areas will cause corrosion.
- After winter, thoroughly clean the chassis of the vehicle.
- Check the paint finish and trimmings of the body.
 - In case of any cracking of the paint finish, touch up immediately to prevent corrosion to commence from the cracking. In case of paint finish peeling off the metal surface, You are recommend to go to the authorized dealer for the touch-up.
- Keep the inside of the vehicle dry.
 - When transporting chemicals, detergents, fertilizers, salt, etc., appropriate containers must be used for storage. In case of spillage or leakage, clean it immediately and keep it dry.
- Install the mudguard.
 - When driving on saline-alkali areas or gravel roads, fenders can protect the vehicle.
- Park your vehicle in a well-ventilated garage or place with a roof. Don't park your vehicle in a wet, airtight garage.

If you live in a peculiar area or in a peculiar environment, you should pay more attention to driving carefully:

- Dust of saline-alkali or chemical substances on roads will accelerate the corrosion of the vehicle, and in coastal areas or industrial pollution areas, the air also contains salt.
- High humidity accelerates corrosion, especially at temperatures slightly above zero.
- Some parts of the vehicle are always wet and will corrode even if other parts remain dry.

- For vehicles that do not dry quickly due to a lack of ventilation, components will be subject to corrosion when the room temperature is too high.

LONG-TERM STORAGE OF VEHICLE

If your vehicle needs to be stored for a long time (more than one month), the following preparations should be made, and proper preparations can help prevent the condition of the vehicle from deteriorating. If possible, park your vehicle indoors.

- Please ensure that the balanced capacity of the vehicle battery is not less than 40%.
- Disconnect the negative connection of the low-voltage battery.
- If possible, start the vehicle regularly (preferably once a month).
- Thoroughly wash and dry the exterior of the vehicle.
- Clean the interior of the vehicle to ensure that carpets, upholstery, etc., are completely dry.
- If possible, use a jack to prop up the body to lift the tires off the ground.
- Open a window slightly (if parked indoor).
- Put a folded towel or cloth sheet under the front wiper blades so that they don't come into contact with the front windshield glass.
- Use a breathable covering made of a "porous material" such as linoleum to cover the body, while non-porous materials such as plastic sheets can accumulate moisture and damage the finish.

ADDING FLUIDS

FRONT COMPARTMENT

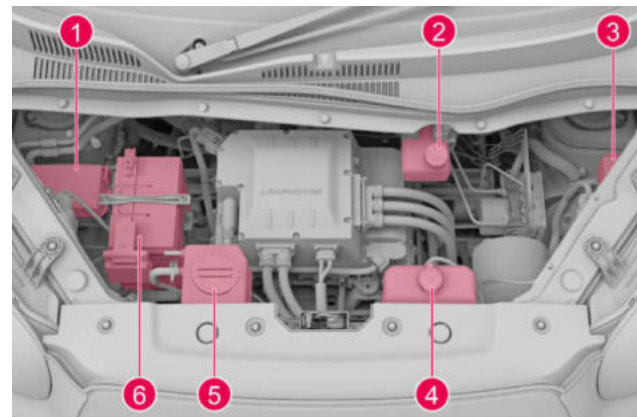

1. Front trunk fuse box
2. Brake fluid pot
3. Auxiliary fuse box in front compartment
4. washer fluid reservoir
5. coolant expansion tank
6. Battery

⚠ WARNING

- The high voltage system of new energy vehicles is dangerous, and for easy identification, orange cables are used for the HV harness. Don't touch, disassemble or replace high-voltage components, orange cables or related connectors. Otherwise, it may cause burns or electric shocks, or even personal injuries or death.

Maintenance and Cleaning

HOOD OPENING

1. Pull up the hood opening handle in the cockpit twice in succession, and the hood produces two "click" sounds and springs up slightly.



2. Raise the hood up and support it with strut bars.

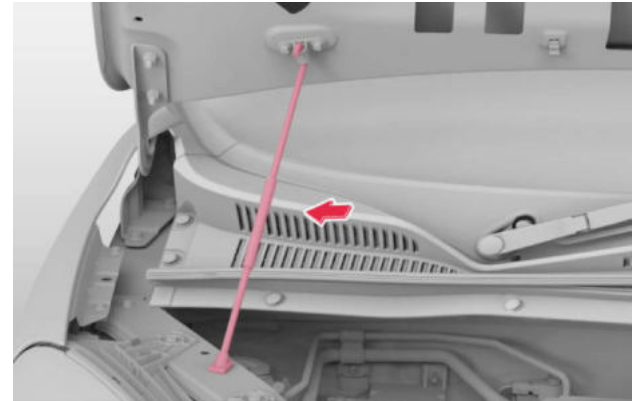

⚠ WARNING

- Don't open the hood while the vehicle is in motion.

ⓘ ATTENTION

- In order to avoid scratches, don't carry anything in your hand (e.g. Vehicle key, jewelry, etc.).

HOOD CLOSING

Before closing the hood, check that no tools, rags, etc. are left in the front trunk, retract the strut bars, and after the hood is slowly lowered to a certain height, release the hood to let it lower freely and ensure that it is locked in place.

If the hood is not fully closed, open the hood again and close correctly.

⚠ WARNING

- Before driving, confirm that the hood is closed and locked, otherwise the hood may suddenly open during driving, resulting in an incident.
- Before closing the hood, ensure that the closing path under the hood is not blocked. Otherwise, there is a risk of personal injuries.

ⓘ ATTENTION

- Don't press hard on the hood to avoid damaging the hood.

CHECKING/ADDING COOLANT

CHECK COOLANT



Check the coolant level from time to time when the coolant is cold, to ensure that the level is between the MIN and MAX marks.

ⓘ NOTE

- The brake fluid can only be changed at the authorized dealer, please complete the maintenance as scheduled according to the maintenance specifications of the main equipment manufacturer.

ADD COOLANT



When the coolant is cold, unscrew the coolant filler cap to add the coolant to the standard, and ensure that the coolant level is between the MIN and MAX marks.

⚠ WARNING

- Don't remove the coolant filler cap when the coolant temperature is high. Otherwise, personal injuries such as burns may occur.
- The coolant must be stored in a marked container that is not accessible to children.

Maintenance and Cleaning

- Avoid having the coolant stick to the skin. If it does, rinse it immediately with water.

NOTE

- If the coolant spills when adding the fluid, wipe it clean with a rag to prevent damage to the parts or paint finish.

ECO

- Waste coolant must be treated in accordance with the local regulations. Don't dump it directly into any garbage, into the sewer or on the ground.

CHECKING/ADDING BRAKE FLUID

CHECK THE BRAKE FLUID

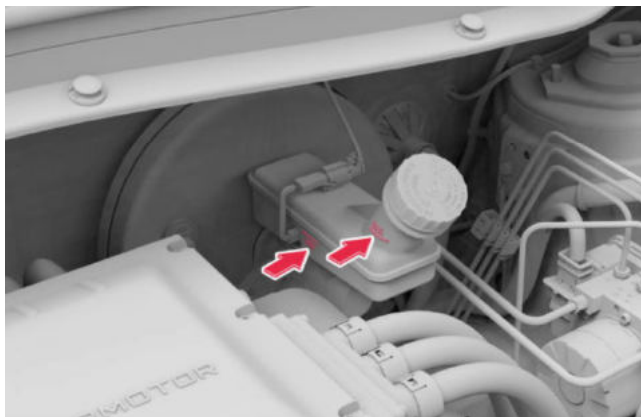

Check the brake fluid level at regular intervals to ensure that it is between the MIN and MAX marks.

NOTE

- The brake fluid can only be replaced at the authorized dealer.
- The brake fluid must be replaced every 3 years or 40,000 kilometers (24,854.85mi) of driving, and the replacement interval should be shortened appropriately under particularly severe conditions.
- The specification of the brake fluid is DOT4.

FILL THE BRAKE FLUID

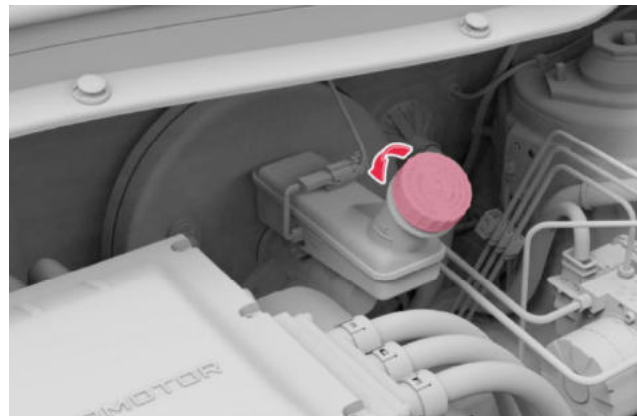

Unscrew the brake fluid reservoir cap to add the coolant to the standard, and ensure that the fluid level is between the MIN and MAX marks.

⚠ WARNING

- Use only new brake fluid stored in a sealed condition. Don't use used or unsealed brake fluid, which absorbs moisture and would reduce the braking performance.
- Brake fluid is highly toxic and must be sealed and kept away from children. In case of accidental ingestion, seek medical attention immediately.
- Don't store brake fluid in empty food containers, bottles or any non-original oil containers, otherwise it may be mistaken for food, resulting in poisoning incidents.
- In the course of use, the vehicle automatically makes adjustments due to the wear of the brake friction lining, and the brake fluid level may drop slightly, which is a normal phenomenon. However, if the liquid level drops in a short period of time, or falls below the MIN mark, or frequent filling is required, it indicates that the brake system leaks.

ⓘ ATTENTION

- The brake fluid damages the painted surface. Don't spill any brake fluid on the paint finish, and in case of any spillage, clean the paint finish immediately with water.
- The brake fluid is absorbent and continuously absorbs moisture from the surrounding air during use. If the moisture content of the brake fluid is too high, it would corrode the brake system, greatly reduce the boiling point of the brake fluid and produce an air resistance during emergency braking, worsening the braking effect, so the brake fluid must be replaced regularly.

♻ ECO

- Waste brake fluid must be treated in accordance with the local regulations. Don't dump it directly into any garbage, into the sewer or on the ground.

ADD WINDSHIELD WASHING FLUID

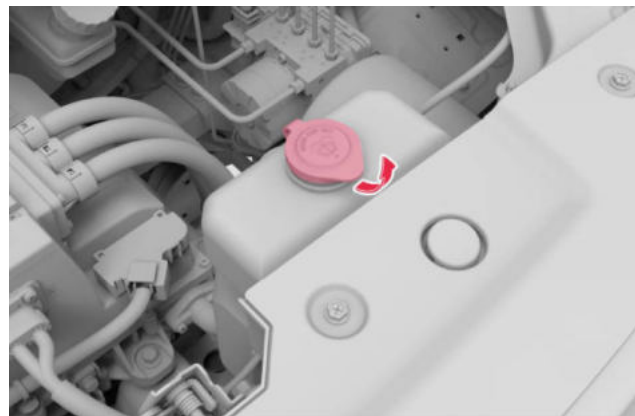

Check the washer fluid in the washer fluid reservoir from time to time. If the volume of the washer fluid is too small, add the fluid. Add the washer fluid with the method as described below:

1. Open the hood and the washer fluid reservoir.
2. Add suitable washing fluid into the reservoir (don't top up).

⚠ WARNING

- Don't add any additive in the washer fluid for the windshield. Otherwise, oil stains or other debris would be left on the front windshield during cleaning, seriously affecting the front vision, and liable to cause accidents.

ⓘ NOTE

Maintenance and Cleaning

- Don't use soapy water or other antifreeze to replace the washing liquid, otherwise stripe marks may occur on the paint finish.
- Don't mix windshield washer fluid with any other cleaning agent, otherwise the compositions of the cleaning agent may decompose and block the nozzle of the windshield washer.

WIPER

WIPER MAINTENANCE

When replacing a wiper blade, you should enable the Wiper Maintenance Position. When the vehicle is stationary and the front wipers are not engaged, you can enable the Wiper Maintenance function on the Vehicle Control - Maintenance interface on the Infotainment Screen and set the front windshield wiper blades to the Maintenance Position.

After you have completed the inspection and replacement, please reset the wiper blade. Turn off wiper maintenance on the Infotainment Screen, and the wiper blade will wipe from the maintenance position once and then stop at the initial position.

NOTE

- Wiper maintenance cannot be enabled when the vehicle is not powered on or the instrument cluster is "READY".

REPLACING WIPER BLADES

1. Enable the Wiper Maintenance Position.
2. Lift the wiper arm to be replaced.

ATTENTION

- Don't open the hood when the wiper arm is lifted up; otherwise, the hood and the wiper arm would be damaged.
3. Press the fixing clip on the wiper blade while sliding the blade down the arm.

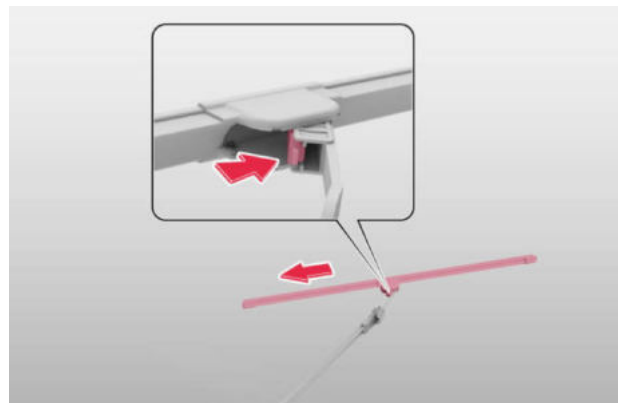

4. Push the new wiper blade hard in the direction shown in the figure until a "click" sound is made.

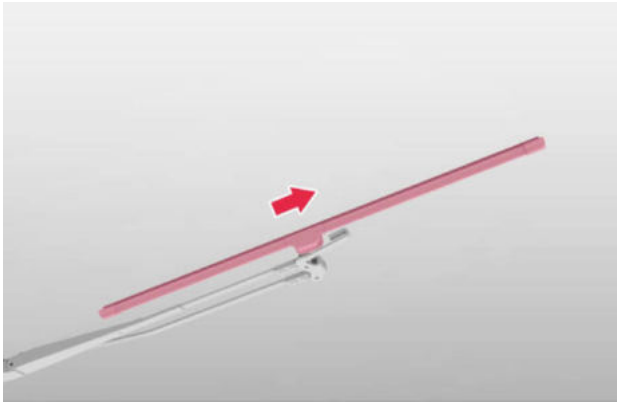

5. Reset the wiper arm to the front windshield.
6. Turn the Wiper Maintenance Mode off on the Infotainment Screen to return the wipers to their normal position.

ATTENTION

- After the wiper blade is replaced, place the wiper arm slowly on the front windshield with your hand to avoid it from dropping too fast and damaging the front windshield.
- Don't make the wipers come into contact with gasoline, kerosene, paint thinner or other solvents to avoid damages.
- Don't shake the wiper arms to avoid damaging the arms and other parts.
- The wipers cannot be used if the Wiper Maintenance Mode is not turned off on the Infotainment Screen.

BULBS

BULB INSPECTION

Regularly check the operation of external lamps. Damaged bulbs can seriously affect driving safety by reducing the visibility of the vehicle and its ability to signal alerts to other road participants.

REPLACING BULBS

Bulbs should be replaced by a professional. Please contact the authorized dealer for replacement.

WARNING

- Bulbs are pressurized and may explode when replaced, causing personal injury.
- Modifications or additions to external lamps and signaling devices are prohibited.

FOGGING OF HEADLAMPS

Under certain humid conditions (such as high air humidity, after washing, etc.), a layer of fog or even a small amount of water droplets may cover the headlamp cover, due to the difference in temperature between the interior of the headlamps and the outside air, similar to fogging of the windows on a rainy day, which is a normal physical phenomenon and will not affect the function or the life of the headlamps.

ⓘ ATTENTION

- If a large amount of water beads or accumulates inside the cover, please contact an authorized dealer for check and repair.

REPLACING FUSES

FUSE DESCRIPTION

The fuses of the vehicle is intended to prevent damages to the harness due to short circuits or overloading. These fuses are installed in four fuse boxes, namely, the fuse box in the front trunk, the auxiliary fuse box in the front trunk, the battery positive fuse box and the instrument cluster fuse box.

To inspect and replace fuses, ensure that the vehicle is powered off.

CHECKING FUSES

If you suspect that a fuse is broken, you can take it out of the fuse box with fuse tongs against the fuse location diagram.

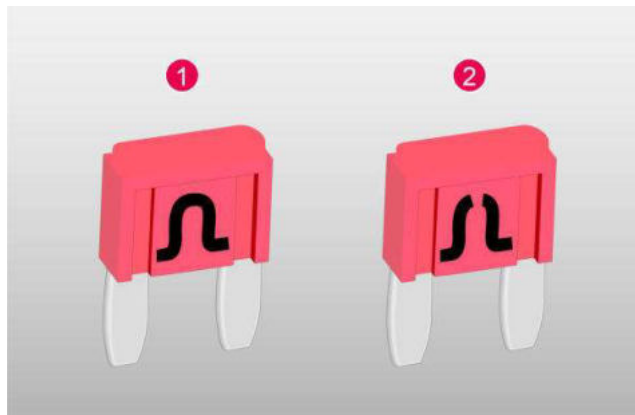

1. Normal fuse
2. Blown fuse

ⓘ NOTE

- Check whether the metal wire inside the fuse is blown. If so, replace it.
- The fuse clip is placed inside the front trunk fuse box.

REPLACE THE FUSE

If you cannot determine whether a fuse is blown, replace the suspicious fuse with a normal spare fuse.

If a fuse is blown, install a new fuse into the fuse holder. Only fuses with the same current rating on the fuse box cover can be installed.

ⓘ ATTENTION

- Don't replace the fuse with a fuse or any other object with a current higher than the rated current, otherwise it will cause serious damage to the electrical system and may cause a fire.
- The inside of the fuse box must be kept clean and protected from moisture.
- Don't attempt to repair a blown fuse before continuing to use it, otherwise a fire may occur due to cable overload.
- If a correct fuse is replaced and still blows out in a short time or the electrical components do not resume normal operation, the vehicle may have a serious electrical system fault. Please contact the authorized dealer immediately for repair.

FRONT TRUNK FUSE BOX

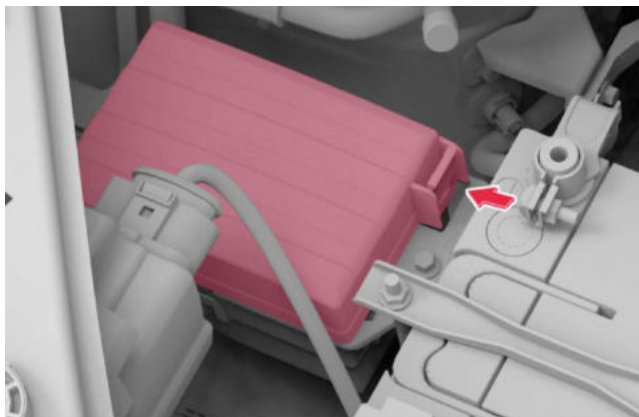

The fuse box in the front compartment is located at the right rear side of the front compartment. Open the hood, press the latch in

the direction of the arrow, and pull open the cover of the fuse box to check and replace the fuses.

LOCATION OF FRONT COMPARTMENT FUSES

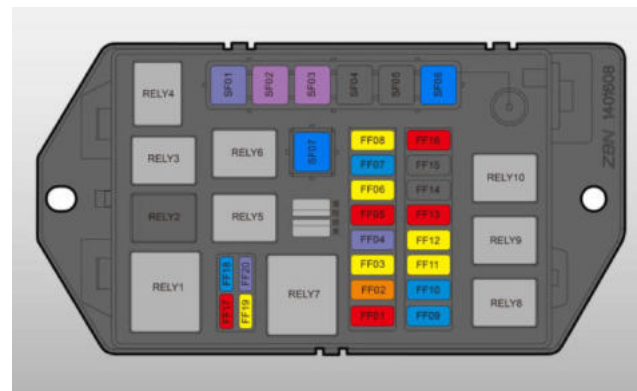

FUSE

Code	Rated current	Protected units or functions
FF01	10A	MCU fuse
FF02	5A	Brake switch fuse
FF03	20A	Low-speed fan fuse
FF04	25A	ON3 fuse
FF05	10A	EPB switch fuse
FF06	20A	Main relay fuse

Maintenance and Cleaning

Code	Rated current	Protected units or functions
FF07	15A	ON2 fuse
FF08	20A	Rear defroster fuse
FF09	15A	Left headlamp fuse
FF10	15A	Right headlamp fuse
FF11	20A	BCM4 fuse
FF12	20A	BCM5 fuse
FF13	10A	Battery fuse
FF14	-	-
FF15	-	-
FF16	10A	Slow charging fuse
FF17	10A	Spare fuse
FF18	15A	Spare fuse
FF19	20A	Spare fuse
FF20	25A	Spare fuse
SF01	25A	High-speed fan fuse
SF02	30A	Vacuum pump fuse
SF03	30A	Blower fuse
SF04	-	-

Code	Rated current	Protected units or functions
SF05	-	-
SF06	40A	ESCI motor fuse
SF07	40A	ESCI valve fuse

RELAY

Code	Rated current	Protected units or functions
RELY1	-	Vacuum pump relay
RELY2	-	-
RELY3	-	Main relay
RELY4	-	Rear defogger relay
RELY5	-	Low-speed fan relay
RELY6	-	High-speed fan relay
RELY7	-	Blower relay
RELY8	-	Headlamp relay
RELY9	-	ON2 relay
RELY10	-	ON3 relay

AUXILIARY FUSE BOX IN FRONT COMPARTMENT

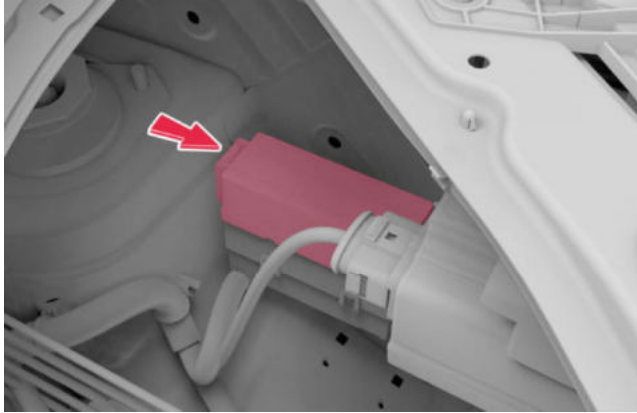

The auxiliary fuse box in the front compartment is located at the left rear side of the front compartment. Open the hood, press the latch in the direction of the arrow, and pull open the cover of the auxiliary fuse box to check and replace the fuses.

LOCATION OF AUXILIARY FUSES IN FRONT COMPARTMENT

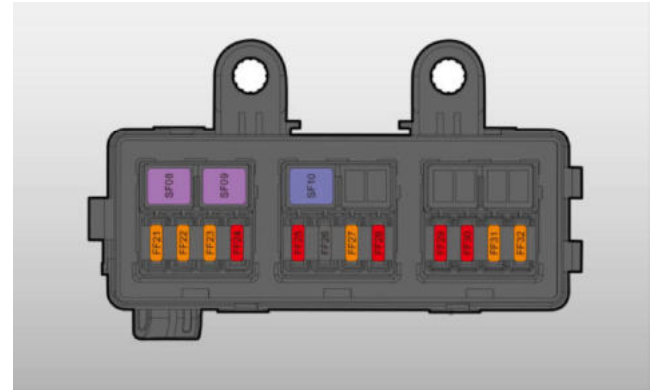

FUSE

Code	Rated current	Protected units or functions
FF21	5A	MCU ON2 fuse
FF22	5A	BMS ON2 fuse
FF23	5A	BCM feedback ON2 fuse
FF24	10A	Pedestrian warning ON3 fuse
FF25	10A	EPS ON3 power fuse
FF26	-	-
FF27	5A	BCM ON3 feedback electrical fuse

Maintenance and Cleaning

Code	Rated current	Protected units or functions
FF28	10A	ESCI ON3 fuse
FF29	10A	A/C related fuses
FF30	10A	Motor pump fuse
FF31	5A	Main relay feedback fuse
FF32	5A	Feedback fuse of the vacuum pump relay
SF08	30A	BCM1/ left-front and right-rear windows fuse
SF09	30A	BCM2/ right-front and left-rear windows fuse
SF10	25A	BCM3 fuse

BATTERY POSITIVE FUSE BOX

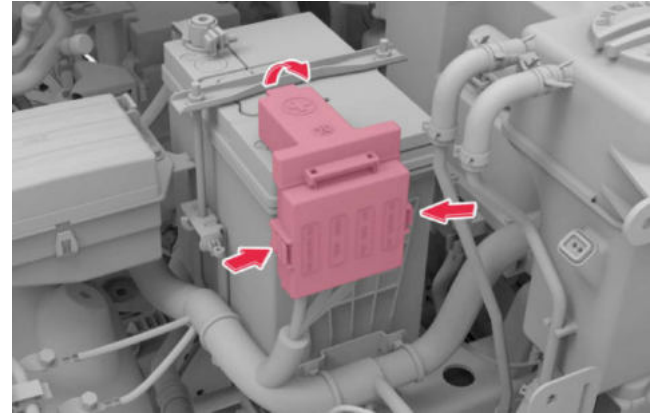

The battery positive fuse box is located at the right front side of the battery in the front compartment. Open the hood, pull up the cover of the battery positive fuse box, press the latches on both sides of the fuse box in the direction of the arrow, and remove the fuse box cover to check and replace the fuses.

LOCATION OF BATTERY POSITIVE FUSES

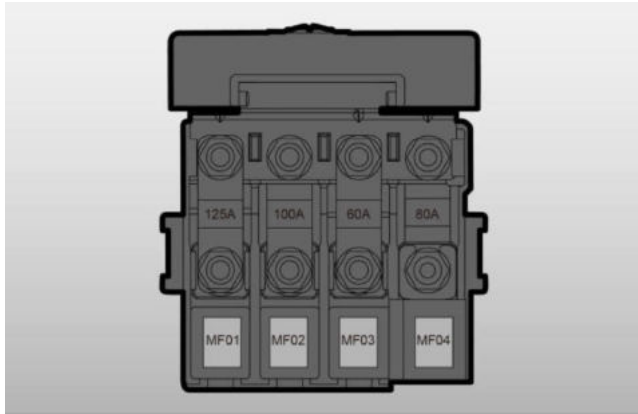

FUSE

Code	Rated current	Protected units or functions
MF01	125A	DCDC fuse
MF02	100A	Main fuse box fuse
MF03	60A	Instrument panel fuse box fuse / auxiliary fuse box fuse
MF04	80A	EPS fuse

INSTRUMENT PANEL FUSE BOX



The instrument panel fuse box is located on the driving side of the instrument panel. Remove the right end cover of the instrument panel to check and replace the fuses.

LOCATION OF INSTRUMENT PANEL FUSES

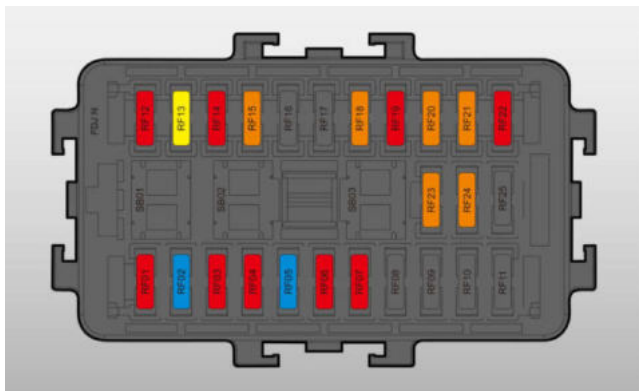

FUSE

Code	Rated current	Protected units or functions
RF01	10A	ESCL fuse
RF02	15A	MMI fuse
RF03	10A	ICU/Front view monocular camera fuse
RF04	10A	OBD/Alcoguard controller fuse
RF05	15A	Electrical sunshade fuse *
RF06	10A	Ripple controller fuse
RF07	10A	E-CALL fuse*

Code	Rated current	Protected units or functions
RF08	-	-
RF09	-	-
RF10	-	-
RF11	-	-
RF12	10A	ACU ON3 fuse
RF13	20A	Backup power supply ON3 fuse
RF14	10A	Shifter switch ON3 fuse
RF15	5A	E-CALL ON3 fuse*
RF16	-	-
RF17	-	-
RF18	5A	MMI ON2 fuse
RF19	10A	Rearview mirror switch fuse
RF20	5A	Sunshine ON2 fuse
RF21	5A	Electrical sunshade ON2 fuse*
RF22	10A	Alcolog/BSD radar/Front-view ON2 fuse
RF23	5A	IVI/Antenna amplifier ON1 fuse
RF24	5A	ICU ON1 fuse

Code	Rated current	Protected units or functions
RF25	-	-
SB01	-	-
SB02	-	-
SB03	-	-

BATTERY MAINTENANCE

TRACTION BATTERY

The traction battery is the power source of a vehicle and can be repeatedly charged and discharged. The traction battery is charged by an external power source. When the vehicle is braking or coasting, the traction battery can also be charged by energy recovery.

NOTE

- The traction battery is placed under the chassis of the vehicle body. When the vehicle is driving on bumpy or uneven roads, be careful to prevent collisions.

BATTERY FEATURES

Due to the influence of the electrochemical properties of the battery itself and for the purpose of protecting the traction battery, the performance of the vehicle has certain differences under the following circumstances, which is a normal phenomenon:

- When the traction battery is at a high charge, the vehicle feedback performance will weaken, and when the charge decreases, it will increase; the feedback performance has an enhanced transition stage.
- When the traction battery is charged to a high charge, it will switch to the trickle charging mode, and the terminal charging time will be extended. The estimated remaining charging time displayed on the instrument cluster will have a deviation.
- When the traction battery is at a low charge, the acceleration performance of the vehicle will be reduced.
- The charging and discharging capacity of the traction battery will decrease at a high or low temperature, and the charging time will become longer, which is a normal phenomenon. When driving in extreme temperatures, there may be a reduction in power performance.
- The available power of the traction battery will decrease at a low temperature, and the available power will decrease as the temperature decreases. When the vehicle with a high level of battery energy remaining is parked and charged in a low temperature environment, the SOC may jump to 100%.

Under normal traction battery conditions, the driving mileage of a vehicle is affected by the following factors:

- Driving habits: For example, the range under frequent acceleration and deceleration is shorter than that under a constant speed, and the range under high-speed driving is shorter than that under low-speed driving.
- Road conditions: For example, the driving mileage of bumpy roads or long slopes will be shorter than that of flat and dry roads.
- Temperature: The range in a low-temperature environment is shorter than that in a normal-temperature environment.
- Usage of electrical equipment: the driving mileage when the A/C is on during vehicle use, may be shorter than that when the A/C is off.

Maintenance and Cleaning

During low-temperature DC charging, the temperature control system can significantly improve the low-temperature charging capacity of the battery and improve the charging performance of the vehicle.

During low power AC charging at a low temperature, due to limited charging power, the self-heating capacity of the battery is low. To increase the charging capacity, battery heating will be enabled at this time, the heating energy consumption will increase compared to DC charging, and the charging time will increase, which is a normal performance of charging in low temperature environments.

-To improve the vehicle experience, you are recommended to charge the battery immediately after the vehicle is used. At this time, the battery temperature is relatively high, which can improve charging performance. If the battery temperature is low, the battery may quickly be in the charge end state to avoid damage to the battery.

When the A/C is on during low temperature charging, the performance of the battery temperature control system will be affected, and the charging performance of your vehicle will also be affected.

RECOMMENDATIONS FOR USING BATTERIES

To extend the service life of the traction battery and improve your vehicle experience, we recommend:

- Use the vehicle at an ambient temperature between -10~40 °C. When the battery is low, to ensure sufficient driving mileage and good acceleration performance, please charge it in a timely manner.
- Don't park your vehicle in an environment with temperature over 40°C for more than 15 days, otherwise the service life of the traction battery would be reduced.
- When using a vehicle, it is recommended to avoid frequent rapid acceleration and deceleration, and to choose a flat and dry road for driving. If necessary, turn off high-power electrical equipment such as the A/C or adjust the temperature of the A/C to reduce the power consumption of high-power electrical equipment and increase driving mileage.
- Using a portable AC charger for charging will extend the service life of the traction battery.
- If you use the vehicle for the first time or park it for a long time before reusing the vehicle, there may be a deviation between the SOC displayed on the instrument cluster and the actual SOC. It's recommended to fully charge the battery first.
- To keep the traction battery in optimal condition, please regularly use a charging device to fully charge the traction battery (it is recommended to fully charge the battery at least once a week).
- Under extreme operating conditions (such as continuous rapid acceleration and deceleration), if the temperature of the traction battery is too high, the discharge capacity of the traction battery will gradually decrease, which is a normal phenomenon. If the battery temperature continues to rise, the traction battery overheat warning indicator on the instrument cluster will be on. At this time, it is recommended to contact the authorized dealer.
- The slow heating mode is used for battery heating. When driving for a short time, the effect of the battery temperature control system is not obvious, and it also increases power consumption and shortens driving mileage. After driving for a long time, the battery temperature rises continuously as the battery itself heats up. At this time, your vehicle's battery heating demand is low. The battery temperature control system is mainly intended to ensure the low-temperature charging performance, to better enhance your experiences with the vehicle.
- If the vehicle is parked for a long time, it can be placed in areas with a high temperature such as underground garages and

warm warehouses to reduce battery heat loss and ensure vehicle performance.

WARNING

- To avoid personal injury, do not directly contact the traction battery.
- Do not touch the liquid if it leaks when the traction battery is damaged; if it gets into the skin or eyes, rinse immediately with plenty of water and seek medical attention immediately.
- If the vehicle is on fire, use a special fire extinguisher to extinguish the fire. Don't use a water-based fire extinguisher to extinguish the fire.
- If the traction battery suffers serious mechanical damage, resulting in the exposure of internal HV components, there will be a risk of severe combustion and electric shock, which may lead to serious casualties and environmental pollution.
- It is strictly forbidden to touch positive and negative terminals of the traction battery pack at any time.
- Don't spray, step on, impact or damage the unit to avoid a fire or explosion of corrosive chemicals.
- Don't disassemble, move, or modify the traction battery components and their harnesses, as this may cause serious burns or electric shock, which may result in personal injuries or death. The orange cables are high-voltage harnesses, and users cannot repair the high-voltage system of the vehicle by themselves. If there is any maintenance need, it is recommended that you go to the authorized dealer for repair.

ATTENTION

- Park your vehicle at a dry place, and try to avoid parking in a wet parking area with water.
- Avoid exposing your vehicle to a high temperature environment for a long period of time, so as not to affect the safety and service life of the battery.

- To ensure traction battery safety, vehicles should be parked away from inflammables, explosives, ignition sources and various hazardous chemicals.
- The available power of the battery will decrease as the vehicle usage time increases.
- Vehicles shall be parked away from heat sources and shall not be exposed to sunlight for a long time, otherwise the service life of the traction battery will be shortened.
- If the vehicle is not used for a long time (more than 7 days), it is recommended to keep the SOC at 40% to 60%, which will extend the service life of the traction battery; If the vehicle is not used for more than 3 months, the battery must be fully charged every 3 months and then discharged to 40%~60%. Failure to operate in accordance with the specifications may cause excessive discharge of the traction battery, reduce battery performance, or even damage. The resulting vehicle faults and damage will be beyond the scope of warranty.
- Avoid frequently charging your vehicle under DC large powers, otherwise the service life of the traction battery would be affected.
- If the battery energy is reduced to 0%, the battery must be charged in time. If it is not charged after a long period of time, it may be unable to be charged any longer. Prolonged loss of power in the vehicle can also cause permanent damages to the battery. If the vehicle cannot be charged, you are recommend to contact the authorized dealer immediately.

TRACTION BATTERY RECYCLING

When the vehicle reaches the scraping condition, please recycle the traction battery in accordance with local regulations.

Maintenance and Cleaning

LV BATTERY

USE AND MAINTENANCE OF LV BATTERY

To extend LV storage battery life and maintain the normal operation of the vehicle electrical system, we recommend that:

- Prevent the battery from overcharging or long-term power loss.
- The battery should be kept away from heat sources and open flames, and ventilation should be maintained during charging to prevent burns and injuries.
- Prevent the battery from high current discharge for a long time.
- The battery should be firmly installed on the vehicle to reduce vibration.
- Often check whether the battery terminal clamps are secured and effectively contacted to prevent sparks that may result in a battery explosion. The oxides and sulfates generated by the battery retaining clips must be scraped away and coated with petrolatum to prevent corrosion.

⚠ WARNING

- Battery electrolyte is corrosive. In case of contact with eyes or skin, rinse immediately with plenty of water and seek medical attention.

📌 NOTE

- When driving in cold areas, it is necessary to avoid complete discharge of the battery to prevent freezing of the electrolyte.
- Make sure to turn off electrical equipment such as lamps, media, etc. when you leave the vehicle.
- After the battery is disconnected and reconnected, the automatic lifting and lowering function and the anti-pinch function of the windows and the anti-pinch function of the sunroof are unavailable.

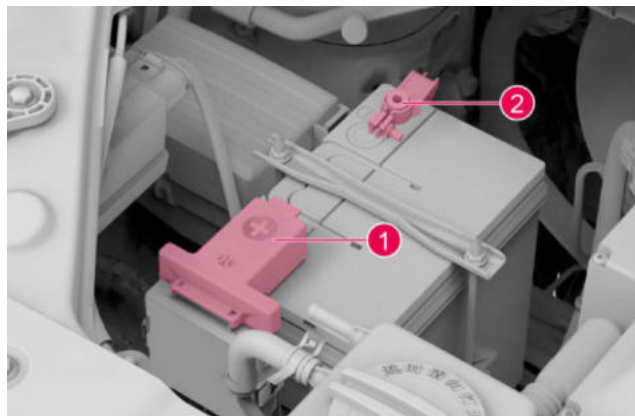

1. Positive pole
2. Negative pole

Frequently inspect the surface of the battery and the positive and negative terminals to ensure that the positive and negative terminals of the battery are not loose or corroded.

Check the appearance of the battery for cracks, expansion and other defects. In the above-mentioned case, go to the authorized dealer for maintenance as soon as possible.

During battery charging, the hydrogen generated by the battery is a flammable and explosive gas. Therefore, care shall be taken for the followings before charging:

- To charge a battery with a battery charger, remove the battery to prevent accidents.
- To connect and disconnect the charger cable from the battery, make sure that the power switch on the charger is turned off.

REPLACING THE LV BATTERY

-The used batteries must be replaced with the batteries of the same model and specification. Replace the battery at the authorized dealer.

ECO

- Recycle the LV battery in accordance with the requirements of the local regulations.

STORAGE OF VEHICLE

Due to the natural discharge and the depletion effect of specific electrical equipment, the energy stored in the battery will gradually be consumed even if the vehicle is not used. If the vehicle is not used for a long time, disconnect the negative terminal of the battery, check the battery energy periodically, and start the vehicle to charge the battery if necessary.

REGULAR MAINTENANCE



REGULAR MAINTENANCE

MAINTENANCE IMPORTANCE

Regular maintenance will help to prolong the service life of the vehicle and improve the driving safety of the vehicle. Failure to maintain the vehicle in accordance with the provisions may lead to excessive wear of some vehicle parts, decline of power performance, impact on driving safety, increase of economic expenditure and so on.

PRECAUTIONS FOR ROUTINE MAINTENANCE

Routine vehicle maintenance is an important measure to ensure driving safety and maintain good vehicle conditions. You can refer to the relevant instructions of the This Manual to complete the routine vehicle maintenance by yourself or in the Service Center. The following items shall be checked before driving. If you find anything abnormal, please contact the authorized dealer.

- Check whether the traction battery charging capacity is normal.
- Check whether the coolant/brake fluid/windshield cleaning fluid level is normal.
- Check whether all lights and horns are working properly.
- Check the wear condition of tyres and if the tyre pressure is normal.
- Check the braking effect of the brake system.
- Check whether there is fault warning information of the instrument cluster and if the information displays properly.
- Check whether the switches are working properly.
- Check whether the seat belt buckle is working properly.

MAINTENANCE CONTENT

Maintenance item		Content
tr ac ti o n b at te ry	Battery box body	Check around the battery box body for irritating, charring and other odors.
	High/low-voltage connectors and ground harness	Check whether the high/low-voltage connectors are clean, corroded, damaged, and whether the connection is reliable; whether the grounding harness is firm and not loose.
	Battery box body and chassis bolts	Check the battery box (including the rear suspension beam) and the chassis bolts for proper torque, and check for corrosion and rust.
	Cleanliness of outside of lower box body	Check the lower battery box for any corrosion or deformation; check the PVC coating on the bottom of the lower box for scratches, corrosion, damage, or peeling; clean the box to ensure it is kept clean.
	Clean the outer side of the upper	Check if there are cracks, bulges, etc. on the upper box cover; Check if the balance valve is secure; Remove dust from the box to ensure good cleanliness.

Maintenance item		Content
	box cover	
	Battery box protection plate	Check whether the battery box protection plate is damaged, falling off and so on.
	Box body air pressure balancing valve and water pipe interface	Check whether the box body air pressure balancing valve is firm without damage, and whether there are traces of coolant leakage or deformation at the water pipe interface.
	Battery parameters	Check the status parameters (alarm information, fault information), SOC, temperature, cell voltage, Pack insulation resistance value, and software version.
	Battery pack positioning hole sealing plug	Check whether the battery pack positioning hole sealing plug is intact, falling off and loose.
	Battery pack nameplate and	Check whether the battery pack nameplate and warning label are missing and falling off, and whether the information is complete.

Maintenance item		Content
	warning label	
B o d y / c h a s i s a n d a c c e s s o r i e s	Exposed bolts and nuts	Check the torque of exposed bolts and nuts, and tighten them in place as required.
	Friction disc	Check the wear condition of the friction plate. It is recommended to replace it if the thickness of front and rear brake pad is less than 3mm. If there is an alarm sound, replace it directly.
	Brake disc	Check the brake disc for wear. When the thickness of the front brake disc is less than 18mm, and the thickness of the rear brake disc is less than 8mm, the brake disc must be replaced.
	Brake fluid	Check the brake fluid level every 1 year or 20,000km (12,427.42mi) and add DOT4 brake fluid for Leapmotor when it is insufficient; the brake fluid must be replaced every 2 years or 40,000km (24,854.85mi), or shorten the replacement period under very bad circumstances.
	Brake hoses and tubes	Check whether the brake hoses/pipes are leaking, damaged, tightened positioned properly.

Regular maintenance

Maintenance item		Content
	Tire	Check the cold tire inflation pressure to ensure they are at the normal level: front tires: 230kPa (unloaded)/250kPa (full loaded), rear tires: 230kPa (unloaded)/250kPa (full loaded); It is recommended to replace the tires every 3 years or 60,000km (37,282.27mi); check the tire tread, and replace if the tread depth is less than 3mm; check tire wear, rotate the tires every 10,000km (6,213.71mi), and tighten the wheel fixing nuts to the specified torque.
	Steering gear dust cover	Check whether the dust cover is damaged and leaking.
	Drive shaft dust cover	Check whether the dust cover is damaged and leaking.
	Door, hood and tailgate hinges	Check whether the fixing bolts are fastened and clean the dust; if they do not move smoothly, you need to oil them or increase the lubricating oil.
	Door check	Check whether the fixing bolts are fastened and clean the dust; if they do not move smoothly, you need to oil them or increase the lubricating oil.

Maintenance item		Content
	Lock	Check the lock function and adjust it if necessary; Regularly clean up the dust and apply oil to the engagement part of the lock.
	Vehicle sealing strip	Check and remove the dust.
	Air spring	Check and clean off the dust.
	Coolant (maintenance-free)	Check if the coolant level is within the standard range. Add the coolant if it is insufficient.
	Wiper blade	Check the wiper blades for wear and aging, and replace them if necessary.
Electric drive assembly	Safety ground harness	Check the tightness of the safety ground harness.
	External part fixing bolts	Check whether the external part fixing bolts are tightened.
	Drive motor	Check the torque of drive motor fixing bolts, and oil leakage holes under the drive motor respirator and the drive motor.

Maintenance item		Content
Reducer		Check the joint surface of the reducer and the oil filler and draining bolts for oil leakage; check the torque of the reducer ventilation plug and the oil marks on the shell of the reducer output end.
Motor U/V/W inter-phase wire and motor grounding wire		Test the resistance of the motor U, V and W inter-phase wire, test the insulation resistance of the motor, and test the grounding resistance of the motor grounding wire.
Water cooling system pipes		Check the water cooling system pipes for aging, deformation and leakage.
Position and temperature sensors		Check the position and temperature sensors, and measure their resistance value and insulation resistance value.
Reducer oil		Replace the reducer oil every 2 years or 20,000km (12,427.42mi).
Assembly housing, electric drive		Clean and inspect the shell of the electric drive powertrain; check whether the electric drive powertrain runs smoothly and makes abnormal noise in no-load lifting state and driving state.

Maintenance item		Content
	powertrain	
Motor controller	Controller four-foot fixing bolts and grounding harness	Check the tightness of motor controller four-foot fixing bolts; check the tightness of the grounding harness.
	Three-phase wire of controller and motor	Check the tightness of the controller and motor three-phase wires.
	DC/DC converter harness and harness terminal bolts	Check whether the bellows skin of the DC/DC converter harness is aged, cracked or detached; Check if the harness terminal bolts are loose.
	Quick charging connector and harness	Check whether the surface of the fast charging connector/harness is intact and undamaged, firm and not loose, whether the bellow skin of the fast charging harness is aging, cracking and falling off,

Regular maintenance

Maintenance item		Content
		and whether the harness terminal bolts are loose.
	PTC/CCM connector	Check that the surface of the PTC and CCM connector/harness is intact, secure and not loose.
Vehicle electronics	Light, horn, wiper and washer	Check and confirm the light, horn, wiper and washer functions of the whole vehicle.
	Moving parts, connectors and harnesses	Check whether the moving parts interfere with the harnesses and are worn, whether the connectors are connected in place; whether the harnesses are fixed in place; and measure the insulation resistance value.
	Water cooling system pipes and water pump	Check the water cooling system pipes for aging, deformation and leakage; check the water tank and pipes for water scale; check whether the water pump works normally.
	Compressor	Test the insulation resistance value of the compressor; test the grounding resistance value of the grounding wire of the compressor.

Maintenance item		Content
	A/C system	Check whether the A/C functions normally, and whether there are leaks and abnormal noises in refrigerant, A/C line and compressor; under normal circumstances, the A/C filter element is cleaned every 6 months or 10,000km (6,213.71mi) (whichever comes first), and the A/C filter element is replaced every 12 months or 20,000km (12,427.42mi)(whichever comes first).
	A/C filter	
	Fast/slow charging cable assembly	Check and clean up the dust in the charging socket; Check if the harness is intact, undamaged, and secure without loosening.
	Vehicle control unit software version	Check whether the vehicle control unit software version is up-to-date and refresh when necessary.

For vehicles that frequently operate under the following harsh conditions, additional maintenance items or shorter maintenance intervals are required. Please contact the authorized dealers for details:

- Driving in high-dust environments such as construction sites and deserts.
- Driving in extremely cold (below 0°C) or hot (above 40°C) temperatures.

- Driving in wet conditions or frequently driving through water.
- Driving on roads with high salt or corrosive materials.
- Driving in mountainous conditions with frequent rapid acceleration and deceleration.
- Used as a taxi or engaged in other operational activities, or often used for special purposes such as high-load use.
- Engaged in racing or competitive activities.
- Additions or modifications without authorization from Leapmotor.

TABLE OF MAINTENANCE INTERVALS

Mainten ance interval	×1, 000 km (62 1.3 7mi)	2 0	4 0	6 0	8 0	1 0 0	1 2 0	1 4 0	1 6 0	1 8 0	2 0 0	2 2 0
Mainten ance item	Nu mb er of mo nth s	1 2	2 4	3 6	4 8	6 0	7 2	8 4	9 6	1 0 8	1 2 0	1 3 2
t r a c t i o n	Battery box body	J	J	J	J	J	J	J	J	J	J	J
	High/low-voltage connectors and ground harness	J	J	J	J	J	J	J	J	J	J	J

Mainten ance interval	×1, 000 km (62 1.3 7mi)	2 0	4 0	6 0	8 0	1 0 0	1 2 0	1 4 0	1 6 0	1 8 0	2 0 0	2 2 0
Mainten ance item	Nu mb er of mo nth s	1 2	2 4	3 6	4 8	6 0	7 2	8 4	9 6	1 0 8	1 2 0	1 3 2
b a t t e r y	Battery box body and chassis bolts	J	J	J	J	J	J	J	J	J	J	J
	Cleanliness of outside of lower box body	J	J	J	J	J	J	J	J	J	J	J
	Clean the outer side of the upper box cover	J	J	J	J	J	J	J	J	J	J	J
	Battery box protective plate	J	J	J	J	J	J	J	J	J	J	J

Regular maintenance

Maintenance interval	×1,000 km (62.137mi)												
		20	40	60	80	100	120	140	160	180	200	220	
Maintenance item	Number of months	12	24	36	48	60	72	84	96	108	120	132	
Box body air pressure balancing valve and water pipe interface		J	J	J	J	J	J	J	J	J	J	J	
Battery parameters		J	J	J	J	J	J	J	J	J	J	J	
Battery pack positioning hole sealing plug		J	J	J	J	J	J	J	J	J	J	J	
Battery pack nameplate		J	J	J	J	J	J	J	J	J	J	J	

Maintenance interval	×1,000 km (62.137mi)												
		20	40	60	80	100	120	140	160	180	200	220	
Maintenance item	Number of months	12	24	36	48	60	72	84	96	108	120	132	
	and warning label												
Body / chassis and accessories	Exposed bolts and nuts	J	J	J	J	J	J	J	J	J	J	J	
	Friction plate	J	J	J	J	J	J	J	J	J	J	J	
	Brake disc	J	J	J	J	J	J	J	J	J	J	J	
	Brake fluid	Check every 1 year or 20,000km (12,427.42mi); replace every 2 years or 40,000km (24,854.85mi) (whichever comes first)											
	Brake hoses and tubes	J	J	J	J	J	J	J	J	J	J	J	

Mainten ance interval	×1, 000 km (62 1.3 7mi)	2 0	4 0	6 0	8 0	1 0 0	1 2 0	1 4 0	1 6 0	1 8 0	2 0 0	2 2 0
Mainten ance item	Nu m b e r o f m o n t h s	1 2	2 4	3 6	4 8	6 0	7 2	8 4	9 6	1 0 8	1 2 0	1 3 2
e s s o r i e s	Tire	Please conduct routine inspection during each maintenance; replace every 3 years or 60,000km (37,282.27mi) (whichever comes first)										
	Steering gear dust cover	J	J	J	J	J	J	J	J	J	J	J
	Drive shaft dust cover	J	J	J	J	J	J	J	J	J	J	J
	Door, hood and tailgate hinges	J	J	J	J	J	J	J	J	J	J	J
	Door check	J	J	J	J	J	J	J	J	J	J	J
	Lock	J	J	J	J	J	J	J	J	J	J	J

Mainten ance interval	×1, 000 km (62 1.3 7mi)	2 0	4 0	6 0	8 0	1 0 0	1 2 0	1 4 0	1 6 0	1 8 0	2 0 0	2 2 0
Mainten ance item	Nu m b e r o f m o n t h s	1 2	2 4	3 6	4 8	6 0	7 2	8 4	9 6	1 0 8	1 2 0	1 3 2
E - d r i v e t r a	Vehicle sealing strip	J	J	J	J	J	J	J	J	J	J	J
	Gas spring	J	J	J	J	J	J	J	J	J	J	J
	Coolant (maintenance-free)	J	J	J	J	J	J	J	J	J	J	J
	Wiper blade	J	J	J	J	J	J	J	J	J	J	J
E - d r i v e t r a	Safety ground harness	J	J	J	J	J	J	J	J	J	J	J
	External part fixing bolts	J	J	J	J	J	J	J	J	J	J	J
	Drive motor	J	J	J	J	J	J	J	J	J	J	J

Regular maintenance

Mainten ance interval	×1, 000 km (62 1.3 7mi)	2 0	4 0	6 0	8 0	1 0 0	1 2 0	1 4 0	1 6 0	1 8 0	2 0 0	2 2 0
Mainten ance item	Nu mb er of mo nth s	1 2	2 4	3 6	4 8	6 0	7 2	8 4	9 6	1 0 8	1 2 0	1 3 2
i n	Reducer	J	J	J	J	J	J	J	J	J	J	J
	Motor U/V/W inter-phase wire and motor ground cable	J	J	J	J	J	J	J	J	J	J	J
	Water cooling system pipes	J	J	J	J	J	J	J	J	J	J	J
	Position and temperat ure sensors	J	J	J	J	J	J	J	J	J	J	J

Mainten ance interval	×1, 000 km (62 1.3 7mi)	2 0	4 0	6 0	8 0	1 0 0	1 2 0	1 4 0	1 6 0	1 8 0	2 0 0	2 2 0
Mainten ance item	Nu mb er of mo nth s	1 2	2 4	3 6	4 8	6 0	7 2	8 4	9 6	1 0 8	1 2 0	1 3 2
M o t o r c o n t r o l	Reducer oil	It is suggested to replace every 2 years or 20,000km (12427.42mi) (whichever comes first)										
	Assembly housing, e- powertrain	J	J	J	J	J	J	J	J	J	J	J
	Controller four-feet fixing bolts and ground harness	J	J	J	J	J	J	J	J	J	J	J
	Three- phase wire of controller and motor	J	J	J	J	J	J	J	J	J	J	J
	DC/DC converter	J	J	J	J	J	J	J	J	J	J	J

Maintenance interval		×1,000 km (62.137mi)	20	40	60	80	100	120	140	160	180	200	220
Maintenance item		Number of months	12	24	36	48	60	72	84	96	108	120	132
Unit	harness and harness terminal bolts												
	Fast charging connector and harness	J	J	J	J	J	J	J	J	J	J	J	J
	PTC/CCM connector	J	J	J	J	J	J	J	J	J	J	J	J
Vehicle	Light, horn, wiper and washer	J	J	J	J	J	J	J	J	J	J	J	J
	Moving parts, connectors	J	J	J	J	J	J	J	J	J	J	J	J

Maintenance interval		×1,000 km (62.137mi)	20	40	60	80	100	120	140	160	180	200	220
Maintenance item		Number of months	12	24	36	48	60	72	84	96	108	120	132
Electronics	and harnesses												
	Water cooling system pipes and water pump	J	J	J	J	J	J	J	J	J	J	J	J
	Compressor	J	J	J	J	J	J	J	J	J	J	J	J
	A/C system	J	J	J	J	J	J	J	J	J	J	J	J
	A/C filter	It is suggested to replace every 12 months or 20,000km (12427.42mi) (whichever comes first)											
	Fast/slow charging cable assembly	J	J	J	J	J	J	J	J	J	J	J	J

Regular maintenance

Mainten ance interval	×1, 000 km (62 1.3 7mi)	2 0	4 0	6 0	8 0	1 0 0	1 2 0	1 4 0	1 6 0	1 8 0	2 0 0	2 2 0
Mainten ance item	Nu mb er of mo nth s	1 2	2 4	3 6	4 8	6 0	7 2	8 4	9 6	1 0 8	1 2 0	1 3 2
Vehicle control unit software version		J	J	J	J	J	J	J	J	J	J	J

- To maintain the traction battery in optimal condition, it is necessary to regularly (at least every 6 months or 7,000km (4,349.6mi)) fully charge and discharge the battery for battery self-calibration. You can also contact the authorized dealer for capacity test and calibration.

The meaning of codes in the table:

- J: "Check, adjust or add if necessary".

ATTENTION

- It is recommended to perform vehicle maintenance in the above maintenance cycle to ensure that the vehicle is in its optimal condition and avoid warranty or repair, replacement and return policy disputes caused by improper maintenance.

NOTE

EMERGENCY TREATMENT



Emergency treatment

OWNER EMERGENCIES

URGENT UNLOCKING/LOCKING

OPEN REAR TRUNK IN EMERGENCY

In case of an emergency, if you cannot open the door or the rear trunk normally in the vehicle, you can urgently open the rear trunk in the following ways.

1. In an emergency, fold and put down the rear seats and enter the trunk area.
2. Remove the emergency switch trim cover on the liftgate.

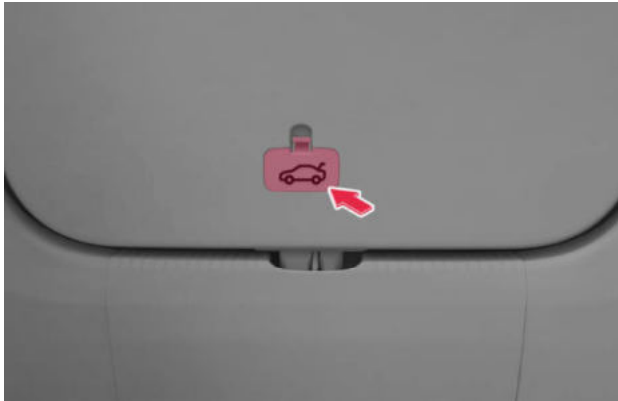

3. Toggle the emergency switch in the direction shown in the diagram, and open the liftgate.

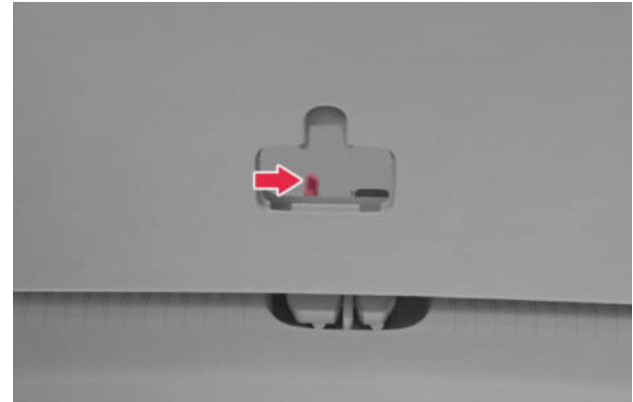

UNLOCKING IN CASE OF COLLISION

In case of a collision during driving, after receipt of the collision signal from the airbag module, all the doors are unlocked, the dome lamp is on, and all the direction indicator lamps flash. The automatic locking function is no longer implemented in the cycle, the locking function of the central control door lock switch is also disabled, and the functions are re-enabled after the vehicle is re-locked and started.

UNLOCKING/LOCKING WITH MECHANICAL KEY

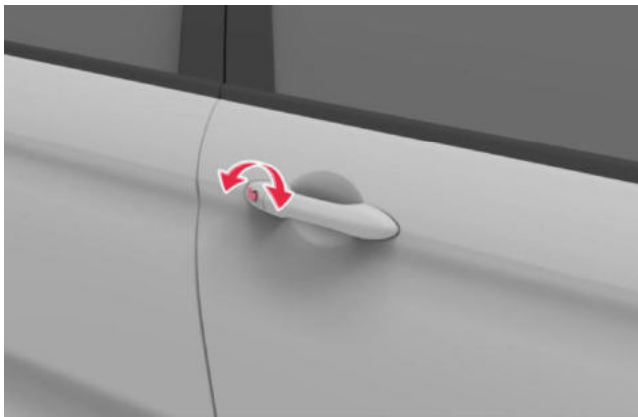

The mechanical key is located in the key fob. When the key fob cannot unlock/lock the doors, the mechanical key can be used to unlock/lock the doors.

Insert the mechanical key into the keyhole in the right front door and turn the key:

- Rotate the key clockwise to unlock the door.
- Rotate the key anticlockwise to lock the door.

NOTE

- Refer to the [Mechanical key](#) (page 30) section for the method to take out the mechanical key.

EMERGENCY UNLOCKING OF CHARGER

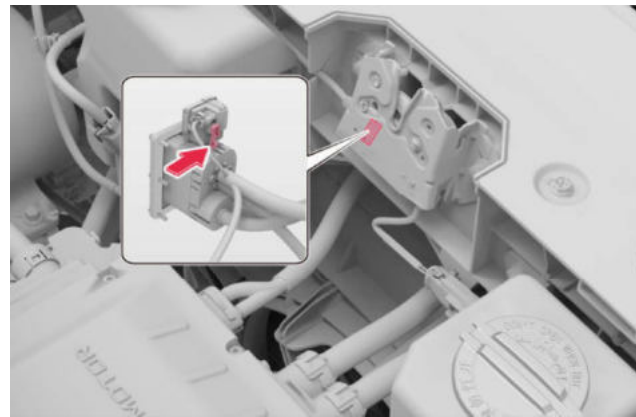

When the vehicle charger cannot be unlocked by tapping Unlock Charger in the Vehicle Control - Quick Control interface or Side Slide Bar interface, disconnect the power supply at the supply end, unlock it manually to try to pull out the charger.

1. Open the hood, the manual unlock button of the charger is located on the inside of the front bumper.
2. Toggle the manual unlocking button on the charger to try to pull out the charger.

INITIALIZATION OF SUNROOF SHADE *

If the sunroof shade cannot be tightly closed or cannot be closed at all with the normal operation method after it is used for several times, initialize the sunroof shade manually.

Emergency treatment



Initialization process:

1. When the vehicle is in "READY" status, manually or automatically operate the sunshade to the fully closed position.
2. Release the button, keep pressing the sunshade closing button again, and hold it.
3. When holding down for more than 10s, the sunroof shade will be initialized: the sunroof shade is locked at fully closed position and then moves back for several millimeters - the sunroof shade is opened to the maximum position - the sunroof shade is closed.
4. After the movements, the sunroof shade is at the fully closed position.
5. Release the sunshade closing button to end the initialization of the sunshade.

⚠ WARNING

- During initialization operations of the sunshade, take care to avoid the passenger's body parts being caught in the closing sunshade, otherwise serious injuries can be caused.

NOTE

- During initialization operations of the sunshade, the sunshade closing button should always be pressed.
- If the sunshade closing button is released during initialization or the vehicle exits the READY state, the movement of the sunshade stops immediately, the initialization operation fails, in this case, repeat these procedures to carry out initiation again.

INITIALIZATION OF SUNROOF SHADE *

If the sunroof shade cannot be tightly closed or cannot be closed at all with the normal operation method after it is used for several times, initialize the sunroof shade manually.



Initialization process:

1. When the vehicle is in Ready state, manually or automatically operate the sunshade to the fully closed position.
2. Release the button, keep pressing the sunshade closing button again, and hold it.
3. When holding down for more than 10s, the sunroof shade will be initialized: the sunroof shade is locked at fully closed position and then moves back for several millimeters - the sunroof shade is opened to the maximum position - the sunroof shade is closed.
4. After the movements, the sunroof shade is at the fully closed position.
5. Release the sunshade closing button to end the initialization of the sunshade.

⚠ WARNING

- During initialization operations of the sunshade, take care to avoid the passenger's body parts being caught in the closing sunshade, otherwise serious injuries can be caused.

📌 NOTE

- During initialization operations of the sunshade, the sunshade closing button should always be pressed.
- If the sunshade closing button is released during initialization or the vehicle exits the READY state, the movement of the sunshade stops immediately, the initialization operation fails, in this case, repeat these procedures to carry out initiation again.

TURNING ON HAZARD WARNING LAMPS



Turning on/off hazard warning flashers: Press the hazard warning flasher key to turn on the red background lamp of the key and the hazard warning flashers, and all the direction indicator lamps and the direction indicator in the instrument cluster flash simultaneously. Press the hazard warning flasher key again to turn off the red background lamp, and the hazard warning flashers turn off.

In the following cases, turn on the hazard warning lamp to attract the attention of other personnel on the road and reduce the risk of traffic incidents:

- When the vehicle is faulty.
- when there is a traffic jam and your vehicle is at the end of the jammed vehicles.
- when your vehicle tows another vehicle or is towed.

Emergency treatment

NOTE

- If the hazard warning lamps are inoperative, other measures must be taken to draw the attention of other traffic participants to your vehicle, and the measures taken must comply with the relevant traffic regulations.

WEARING THE REFLECTIVE VEST



If you have to get off the vehicle to check or handle vehicle faults during driving, especially at night, take out the reflective vest from the glove box and wear it neatly before getting off the vehicle to check and handle vehicle faults and attract attention from the rear vehicles.

WARNING

- When handling a vehicle accident, regardless of the lighting conditions, be sure to wear a reflective vest as required to attract the attention of pedestrians or other drivers.

NOTE

- After use, properly put the reflective vest into the glove box.
- If the reflective vest is worn or heavily soiled, please replace it with a new one in a timely manner.

KNOWING ATTACHED TOOLS

The attached tools are stored inside the rear trunk.

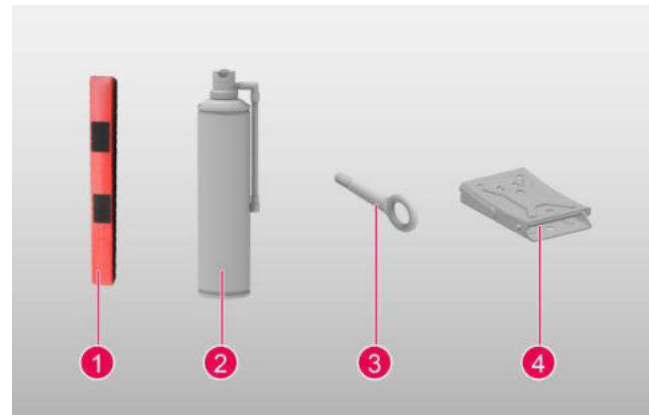

1. Warning triangle
2. Automatic tire sealer inflator
3. Towing hook
4. Stopper

ⓘ NOTE

- To respond to various emergency situations, you should be familiar with the positions and use methods of tools. After use, tools should be cleaned promptly and placed back in their original positions.

SETTING UP THE WARNING TRIANGLE

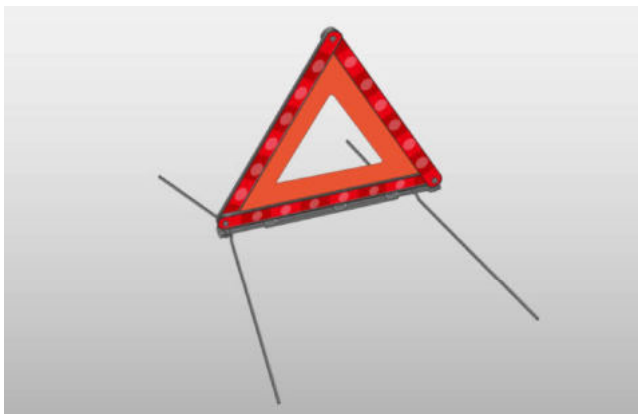

The warning triangle is stored inside the rear trunk. Take it out and unfold it to use.

ⓘ NOTE

- Correctly use the warning triangle in accordance with the relevant local laws and regulations.

EMERGENCY TREATMENT OF TIRES

TIRE BURST



If a tire blowout occurs during driving, hold the steering wheel tightly with both hands and lightly step on the brake pedal to slow down the vehicle and drive in a straight line in the original direction. After slowly driving to a safe position, wait for rescue.

⚠ WARNING

- Don't forcefully slam the brake pedal, otherwise the vehicle may lose its center of gravity and lose control or roll over.
- Turn on the hazard warning lamp in a timely manner, and place a warning triangle at the rear of the vehicle as required to remind the rear vehicles to avoid danger.

Emergency treatment

TIRE LEAKAGE



When a tire is found leaking, gently step the brake pedal to slow down, keep driving in a straight line, drive the vehicle off the road to a safe place, and repair the tire or wait for rescue as needed after stopping.

⚠ WARNING

- While repairing the tire or waiting for rescue, turn on the hazard warning flashers, and set up the warning triangle behind the vehicle according to the regulations to remind rear vehicles and prevent dangers.

ⓘ ATTENTION

- Don't keep driving with a leaking tire, even for a short distance, as the tire would be damaged to an unrepairable level.

AUTOMATIC TIRE SEALER INFLATOR



Automatic tire sealer inflator is equipped for this model for troubleshooting such as tire leakage.

⚠ WARNING

- Inhalation of tire repair sealant may be harmful to health, in the case of accidental ingestion of tire repair sealant, it is recommended to seek medical attention immediately and not to induce vomiting.
- If tire repair sealant gets into the eyes or comes into contact with the skin, rinse immediately with plenty of water. If you still feel uneasy, seek medical attention immediately.
- Keep out of reach of children.
- The storage temperature of the self-inflating tire sealer inflator is $-40\sim 85^{\circ}\text{C}$. It is strictly prohibited to place it in a vehicle where the front and rear windshields are exposed to direct sunlight or in

high-temperature areas. It is also prohibited to come into contact with open flames.

ⓘ NOTE

- Before use, please check whether the automatic inflated tire sealant is within the validity period. If it is beyond or near the validity period, please replace it in time.

Tire repair sealant cannot be used to temporarily repair tires in the following cases:

- A tire damage.
- A tire is damaged on the side.
- The spot punctured by a sharp object is greater than 6mm.
- The hub is exposed.
- The hub is damaged.

TIRE REPAIR METHOD

1. Park the vehicle in a safe area, and set up the warning triangle.
2. Uniformly shake the tire repair sealant before use.
3. Remove the tire valve cap.
4. Tear off the safety cover of the connector valve.



5. Tightly fasten the repair sealant connector valve on the tire valve.
6. Unscrew clockwise to open the repair sealant valve, and put the sealant bottle upside down.

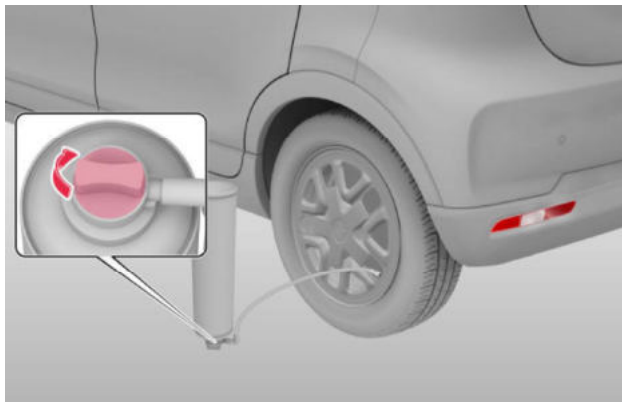

7. When all the repair sealant is inside the tire, close the sealant valve by turning anticlockwise, and screw the valve cap to complete the repair.
8. If the rear tire pressure monitoring shows the pressure between 1.4 and 3 bar after driving of 10km (6.21mi) with speed below 80km/h, you can continue the driving; if it is higher than 3.0 bar, deflate through the tire valve to achieve the recommended pressure; if it is lower than 1.4 bar, stop immediately and call for rescue.

TIRE ROTATION

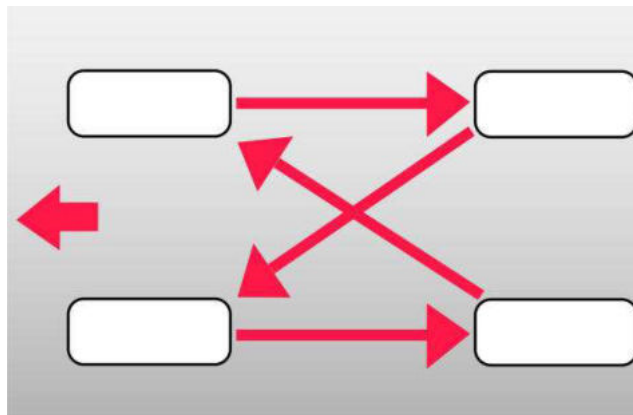

To avoid uneven tire wear and prolong the service life of the tires, the tires should be rotated every 10,000km (6,213.71mi) of driving. After tire rotation, adjust the tire pressure to the specified range.

NOTE

- To switch or replace tires, you're recommended to contact a authorized dealer.

TIRE WEAR INDICATOR

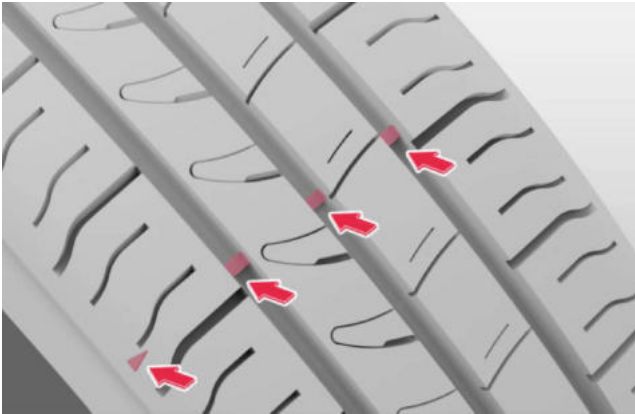

There are wear indicators on tires. The triangular pattern on the outer circle of the tire is used to guide the location of the tire tread wear indicators. You can find the tire tread wear indicators via this pattern.

The height of the raised "tread wear indication mark" is 1.6mm. If the tread pattern is worn to the marking surface, the tire cannot be used safely and must be replaced immediately.

JUMP STARTING

If the low-voltage battery energy is depleted, try to start your vehicle via a jumper cable connected with another vehicle.

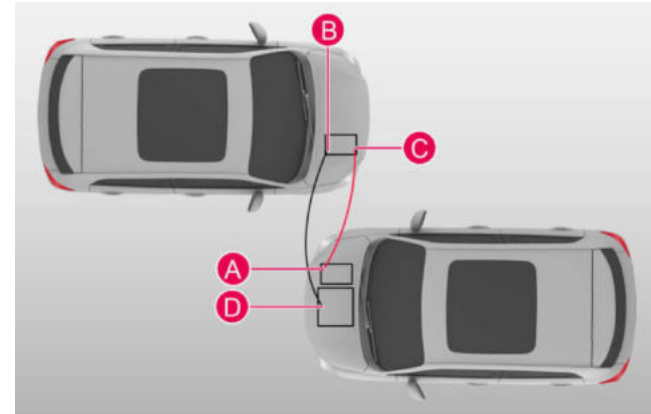

Connect the cable as per the following steps:

1. Connect one end of the red positive (+) cable to the positive (+) terminal (A) of the energy depleted battery.
2. Connect the other end of the red positive (+) cable to the positive (+) terminal (C) of a charged battery.
3. Connect one end of the black negative (-) cable to the negative (-) terminal (B) of the charged battery.
4. Connect the other end of the black negative (-) cable to an unpainted metal part (D) of the drive motor of the energy depleted battery, but keep it away from the running parts of the drive motor and the battery.
5. Start the vehicle with balanced battery energy, and energize the vehicle for some time.

! ATTENTION

- Don't let the other end touch anything before proceeding to the next step.

Emergency treatment

- Don't connect the other end of the black negative (-) cable to the battery without energy.
- Try to start the vehicle without battery energy, if it fails to start after several attempts, the vehicle may need repair, and it is recommended to send the vehicle to an authorized dealer for repair. Note that, during the jump starting, don't overlap the negative terminals of the batteries.
- When starting your vehicle via a jumper cable, the two vehicles cannot contact each other; otherwise, once the positive terminals of the low-voltage battery of the two vehicles are connected, the current may be immediately switched on, causing damages to your vehicle.

Disconnect the jumper cable as per the following steps:

1. Disconnect the black negative (-) cable on the vehicle with no battery energy.
2. Disconnect the black negative (-) cable on the vehicle with battery energy.
3. Disconnect the red positive (+) cable on the vehicle with battery energy.
4. Disconnect the red positive (+) cable on the vehicle with no battery energy.

! ATTENTION

- If the jumper cables are connected or disconnected in the wrong order, an electrical short circuit may occur and damage the vehicle. Any repair caused thereby is not covered by the warranty. Therefore, be sure to connect or disconnect the jumper cables in the correct order, and ensure that the cables do not come into contact with each other or touch other metals.

REPLACING THE REMOTE CONTROL KEY BATTERY

If the vehicle cannot be unlocked/locked when you try to unlock/lock the vehicle with the key fob for several times, you need to replace the key fob battery.

1. Use the appropriate tool to gently slide along the opening gap at the bottom of the key fob to the outer edges of both sides, pry up and remove the rear cover of the key fob.



2. Use a plastic sheet to remove the old battery and insert a new battery (type CR2032) with the '+' side facing the bottom cover (the side with Leapmotor logo).



⚠ WARNING

- Grab the battery by gently holding its edge only. Finger marks on the surfaces of the battery can reduce battery life.

3. Press the bottom cover into position after the replacement.

⚠ WARNING

- The remote key contains a battery. If swallowed, it may cause injury or even life-threatening for a period of time. If swallowed accidentally, please seek medical attention immediately.
- Keep the battery (new or old) away from children. If the battery cannot be properly secured inside the remote key, please use the vehicle's spare key and contact the authorized dealer as soon as possible.
- After using the mechanical key, please place it properly inside the remote key to prevent children from accessing its battery.

ⓘ ATTENTION

- To replace a battery, replacement by professionals of a authorized dealer is recommended.
- Do not replace the battery with sweat or water on your hands to prevent rusting of the battery.

ⓘ NOTE

- Batteries contain toxic and corrosive substances. Please send the depleted batteries to a qualified professional service center or waste battery recycling point.

CHARGING EMERGENCY PLAN

In the process of charging, when the charger is faulty, please unplug the charger. If necessary, please contact the authorized dealer for maintenance as soon as possible.

If the vehicle is in the DC fast charging state of the charging station, and there is smoke, peculiar smell, or internal abnormal phenomenon at the charging port, please press the emergency stop button on the fast-charging pile in a timely manner to stop charging, evacuate personnel around the vehicle, and handle it according to relevant on-site procedures.

If the charging port is damp in the process of charging, on the premise of guaranteeing safety, please disconnect the power supply first, then disconnect the plug at the power supply end, and then unplug the charger at the vehicle end. If necessary, please wear insulating gloves and contact the you authorized dealer for maintenance as soon as possible.

Before charging, please check the skin and shell of the charging cable for damage. If they are damaged, it's recommended to contact the authorized dealer for repair or replacement. Don't use worn charging cables.

Emergency treatment

In case of sudden weather changes (such as wind, rain, snow, thunderstorms, etc.) during the charging process, check whether the charger is secured and dry in time; When lightning strikes, don't touch the charging cable or the body. Stop charging if necessary.

EMERGENCY VEHICLE STARTING



When the battery of the key fob gets too low, place the key fob against the indicated area below the onboard power supply, and press the Start/Stop button while stepping the brake pedal to start the vehicle.

E-CALL*

This model is equipped with the E-CALL system, which automatically dials the emergency number in an emergency through the onboard equipment and sends the vehicle location information and other relevant rescue information to the rescue

service center. When the vehicle is involved in an incident or encounters an emergency, with the owner's authorization, the remote call module will automatically dial the local emergency number and send the vehicle's location and other important information to the rescue service center so that the rescue service can quickly reach the scene and provide emergency assistance.

① NOTE

- The service centers connected by the E-CALL system are not available in all areas.
- The minimum vehicle data set sent to PSAP includes basic information such as vehicle location, number of passengers, and vehicle identification number.
- E-CALL system requires communication through a cellular network.

AUTOMATICALLY TRIGGER THE E-CALL SYSTEM

E-CALL will be automatically triggered if the airbag is deployed or the vehicle rolls over.

MANUALLY TRIGGER THE E-CALL SYSTEM



Status 1*



Status 2*

Open the protective cover of the E-CALL button on the reading light panel and press and hold the E-CALL button to manually dial the emergency number.

NOTE

- Manual triggering can be used in the event of a serious incident or in emergencies occurring inside the vehicle (e.g., sudden cardiac arrest).

CANCEL THE E-CALL SYSTEM

E-CALL can only be canceled if it is triggered manually. It can be canceled by clicking the "Hang Up" button on the Infotainment Screen or pressing the E-CALL button. In addition, the E-CALL can also be hung up by the service center.

Emergency treatment

ROAD RESCUE

GETTING THE VEHICLE OUT OF THE TRAP

If the vehicle is trapped on soft roads such as sand, mud or snow, the following steps can be taken to get out:

1. Turn the steering wheel left and right, grind an area around the front wheels, and remove mud, snow, or sand around the tires.
2. Place wooden blocks, stones, or other materials to improve tire friction.
3. Start the vehicle and accelerate carefully to get the vehicle out of the trap.

ATTENTION

- During the acceleration process, personnel can push the vehicle forward and backward to get the vehicle out of the pit. Moreover, ensure that the surrounding area is spacious and clear to avoid knocking into other vehicles, objects or people. When the vehicle is about to get out of the pit, it may suddenly accelerate sharply forward or backward. Please observe the conditions around the vehicle.
- If the vehicle still fails to get out of the pit after several attempts, a trailer will be required for rescue.

VEHICLE TOWING

If the vehicle is to be towed, it should be towed by the authorized dealer, or a professional trailer company.

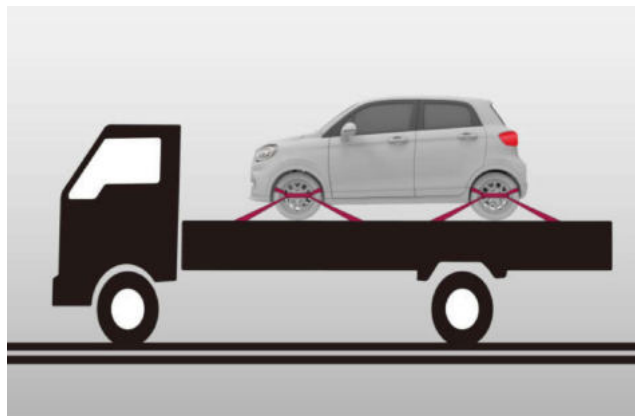

If a vehicle is to be towed due to failure, a flat-bed trailer will be preferred, as landing of the vehicle's front or rear wheels may cause damage to some high-voltage components.

NOTE

- All traction must be done with a safety chain system, and comply with relevant laws and regulations and industry standards.

EMERGENCY TRACTION

When platform type towing cannot be realized in an emergency, a towing cable or towing chain can be fastened on the hook in the front of the vehicle to temporarily tow the vehicle. This method is only suitable for low speed and short distance traction on solid and flat roads.

Front traction

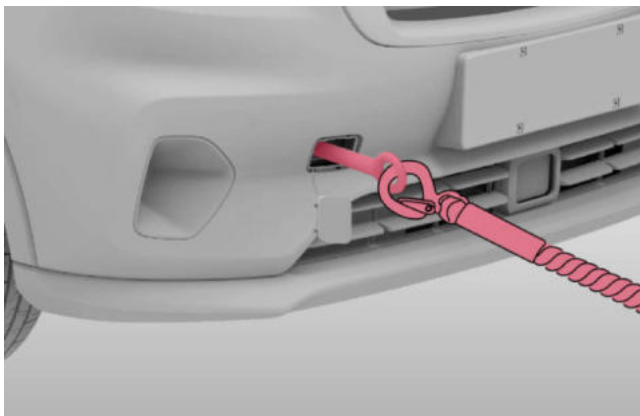

ⓘ ATTENTION

- To tie the vehicle with a trailer rope or trailer chain, don't tie it too tightly, otherwise the vehicle may be damaged.
- In the process of towing a vehicle, the driver must sit inside the vehicle and control the steering wheel and brake pedal to avoid personal injury and vehicle damage during towing.
- Don't drive at a high speed while towing the vehicle.

ⓘ NOTE

- The vehicle can be towed through emergency towing only when the wheels, transmission system, steering wheel and brakes are in good condition. The hazard warning lamps of both the towing vehicle and the towed vehicle shall be on during towing.
- During towing, the towed vehicle should be braked earlier than in normal conditions, but the brake pedal should be gently stepped.

Front tow hook installation method:

1. Take the towing hook out of the attached tools storage area in the rear trunk.
2. Use a tool (slotted screwdriver is recommended) to pry the front towing hook cover plate gap located at the lower right end of the vehicle front to open the towing hook cover.



3. Screw the towing hook clockwise into the mounting hole of the towing hook and tighten it.

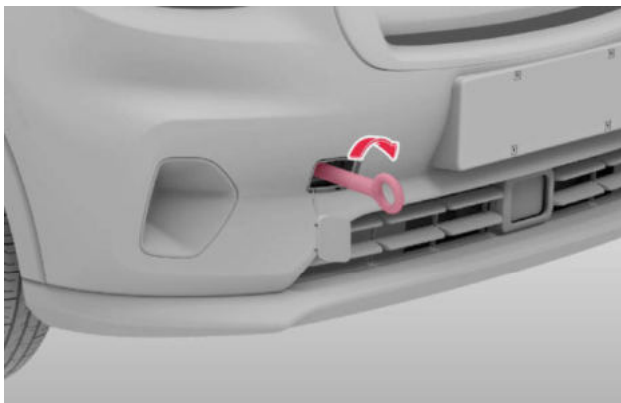

⚠ WARNING

- Fasten the tow hook when attaching it on the vehicle. If the towing hook is loose, it may fall off during towing, causing serious personal injury or damage to the vehicle.
- If the vehicle needs to be pulled out with towing hook as it is stuck in mud or a sandpile, or for other reasons, please ensure that the above precautions are followed, otherwise the towing cable may break due to an excessive force applied,, resulting in serious personal injuries and vehicle damages.

ⓘ ATTENTION

- Before towing, check whether the towing hook is broken or damaged.
- During towing, try to maintain straight traction. Don't tow the vehicle from the side or at a vertical angle to avoid damaging the towing hook.

- Do not yank the towing hook, and exert the force steadily and uniformly.
- If the towing vehicle fails to move, don't continue to forcibly tow it. Please contact the authorized dealer.

Towing

The installation of a rear towing device is prohibited when the vehicle does not have towing capabilities.

⚠ WARNING

- Please do not add a towing device, as it may cause additional damage to the vehicle.
- Adding a towing device can result in incidents and serious injury.

INCIDENT RESCUE

RESCUE OF VEHICLE FIRE

In case the vehicle is on fire, don't touch any part of the vehicle. It shall be operated by professional rescue personnel wearing correct protective equipment, and the trapped passengers in the vehicle shall be evacuated in accordance with the guidance of professional rescue personnel.

The gas inflator in the airbag may be expanded by heat in a high temperature environment and then explode. Please be careful before operation so as not to cause personal injury.

If the fire in the vehicle does not involve the traction battery, put out the fire with the fire extinguisher.

If the traction battery area of the vehicle is on fire, cool it down with plenty of fire water, and monitor the temperature in the

battery area to prevent reburning. Make sure that the battery no longer heats up and store the vehicle on an open flat ground, and set a safety area with a radius of about 15m to prevent unrelated personnel from touching the vehicle.

WARNING

- Provided the safety of people is guaranteed, control the fire as soon as possible to avoid complete combustion of the vehicle, leading to damage to surrounding vehicles or facilities.
- After cooling measures are taken for the traction battery on fire, it is necessary to be alert to the risk of reignition of the traction battery to avoid dangers during transportation.
- The battery may explode when the vehicle spontaneously ignites. Once the fire becomes uncontrollable, please evacuate the scene decisively and call the police.
- After fire extinguishing, it's recommended to contact the authorized dealer for handling. Don't touch the vehicle recklessly after a fire incident to prevent incidents such as electric shocks and burns.

To prevent vehicle fires in a timely and effective manner, the following precautions should be taken during use:

- Don't store inflammables or explosives in the vehicle.
 - In hot summer, if lighters, cleaning agents, perfume and other inflammables & explosives are stored on the vehicle, it is very likely to cause fires or even explosions.
- Don't change vehicle wiring or install additional electrical components.
 - Other electrical devices additionally installed, (such as large-power audio equipment), may excessively increase the load of the line or cause heating of the harness, liable to lead to a fire.

- It is strictly prohibited to replace fuses with new fuses or other metal wires that exceed the rated specifications of electrical appliances.
- You are recommended to go to the authorized dealer for the following checks:
 - Regularly check for oil leakage, timely clean the oil dirt and stains on the motor, to prevent fires caused by ventilation of oil dirt and stains under a high temperature.
 - Regularly check whether the connectors, insulation, and fixed positions of the entire vehicle's wiring, electrical appliances and wiring harnesses are normal. If any problems are found, they should be promptly handled.
- You are recommended to put a fire extinguisher on the vehicle and master its operation method.
 - To ensure driving safety, equip an onboard fire extinguisher, and regularly check and replace the extinguisher.
- Driving precautions:
 - Since the vehicle has a low chassis, it shouldn't be driven on hollow and bumpy roads as much as possible to avoid knocking the chassis and squeezing the traction battery pack. Otherwise, the traction battery may catch fire due to severe compression.
 - In the process of driving, the vehicle should avoid sections with inflammables such as dry leaves, wheat straw and weeds, or stop in a timely manner after passing such sections to check if there are any inflammables attached to the bottom of the vehicle. When parking, avoid direct exposure to sunlight as long as possible.

VEHICLE WADING RESCUE

It is recommended that the vehicle should not be driven in deep water for a long time, otherwise it is liable to cause damage to the HV parts of the vehicle.

Emergency treatment

Professional rescue personnel should wear appropriate rescue protective equipment when dealing with a water soaked vehicle, pull the vehicle out of the water first, and then cut off the high-voltage circuit normally.

WARNING

- Don't touch a water soaked vehicle without wearing rescue protective equipment to prevent electric shocks.
- In case the chassis of the vehicle is impacted or the vehicle is soaked by water, contact an authorized dealer for inspection, to prevent personal injuries or vehicle damages due to a mechanical damage or high-voltage hazard of the traction battery.

ATTENTION

- Don't drive on road sections with unknown water depth to avoid damaging electrical parts.
- Don't drive in salt-laden water logged sections to avoid corrosion of the body.
- Do not drive in water for a long time to avoid damaging the vehicle.

TRACTION BATTERY LEAKAGE RESCUE

In case of leakage of the traction battery liquid, it would seriously affect the safety of the battery, and even cause a fire. Don't go near the vehicle where the traction battery liquid leaks. It is recommended to contact a authorized dealer immediately.

Traction battery liquid leakage should be handled by professional rescue personnel, who should wear a protective mask and solvent-proof gloves. Don't directly touch the liquid.

WARNING

- In case of leakage of the traction battery liquid, avoid skin and eye contact with the liquid. In case of contact, wash with plenty of water and seek medical attention immediately. No person or animal shall swallow any part of the battery or any substance contained in the battery.

ECO

- Don't dispose of any leaked liquid in water, soil and other environment.

TECHNICAL INFORMATION



VEHICLE INFORMATION

VEHICLE IDENTIFICATION NUMBER (VIN)

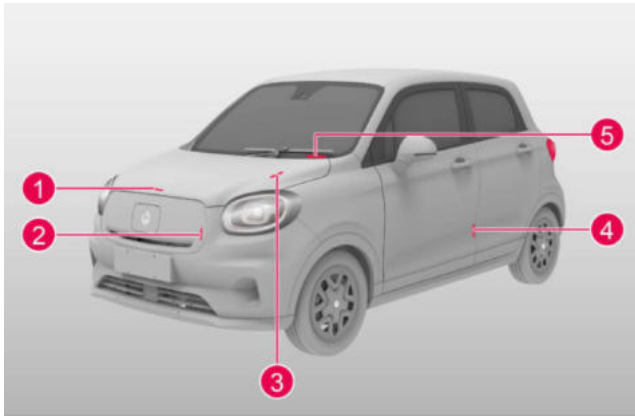

The Vehicle Identification Number (VIN) is a unique identification code of the vehicle, and is engraved or attached at the following locations:

1. At the front of the hood inner panel (attached)
2. On the arc surface of the motor casing (attached)
3. On the left shock tower (attached)
4. Left front door sheet metal (attached)
5. Sheet metal cross beam on lower left side of front windshield (pasting)

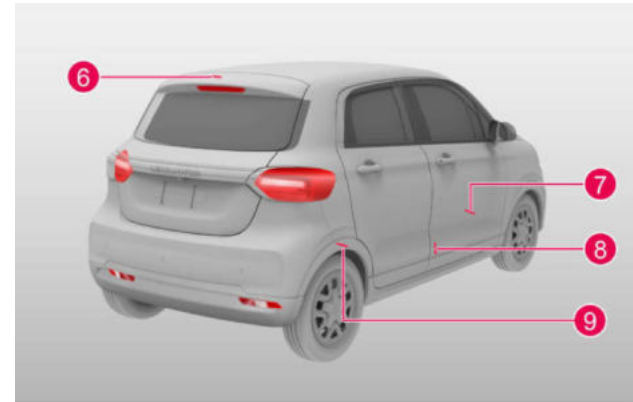

6. On the liftgate inner panel (attached)
7. Located on the floor crossbeam under the right front seat (engraved)
8. Right front door sheet metal (pasting)
9. On the inner panel of right rear wheel housing (attached)

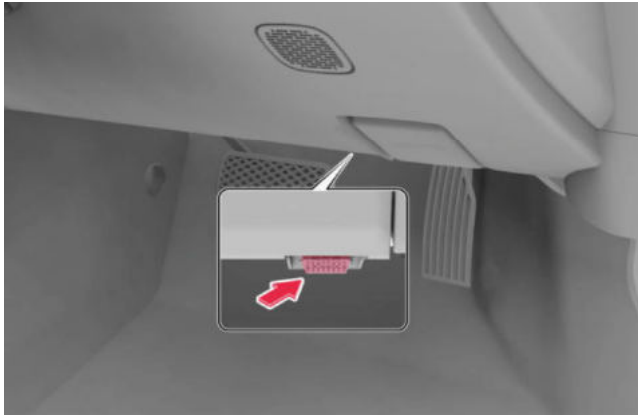

Read the VIN from the OBD interface.

The OBD interface is at the bottom left of the instrument panel, and data such as VIN and vehicle status information can be read with a dedicated diagnostic instrument.

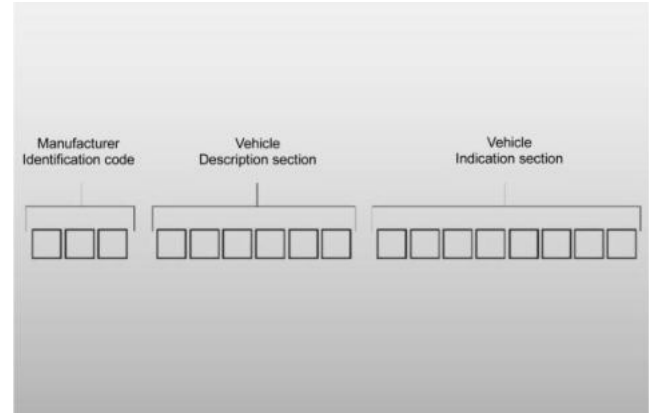

The VIN consists of 17 characters, including the information of country of manufacture, manufacturer, year, and vehicle featured code.

Technical information

VEHICLE NAMEPLATES AND LABELS

MANUFACTURER'S NAMEPLATE



The manufacturer's nameplate is located below the latch on the exterior panel of B pillar on the right side of the vehicle.

The manufacturer's nameplate contains information such as the manufacturer, vehicle model, country of manufacture, year of manufacture, manufacturer's Declaration of Conformity, vehicle identification code (VIN).

A/C WARNING SIGN

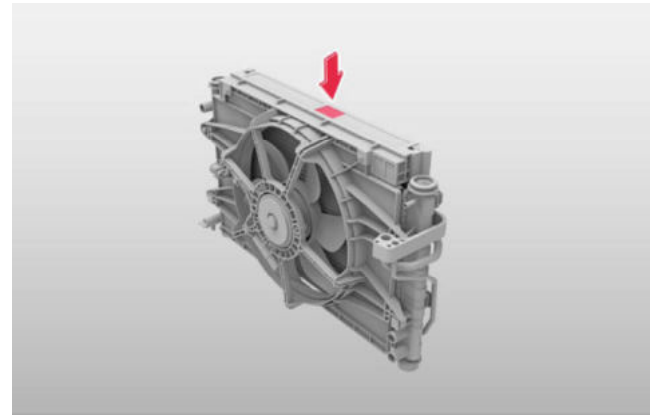

The A/C warning sign is on the fan.

COOLANT WARNING LABEL

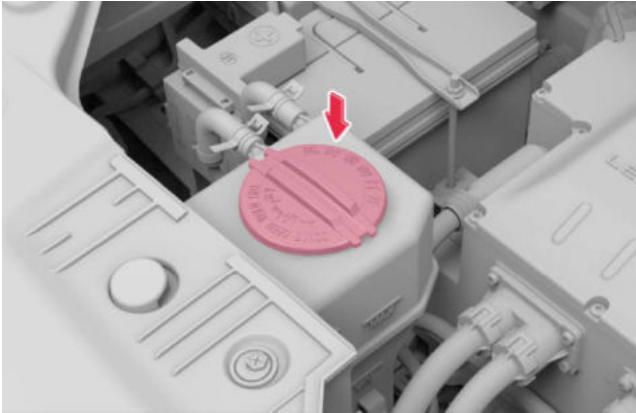

The coolant warning label is pasted on the lid of the coolant expansion tank.

It warns that don't open it when it is hot.

TIRE PRESSURE LABEL

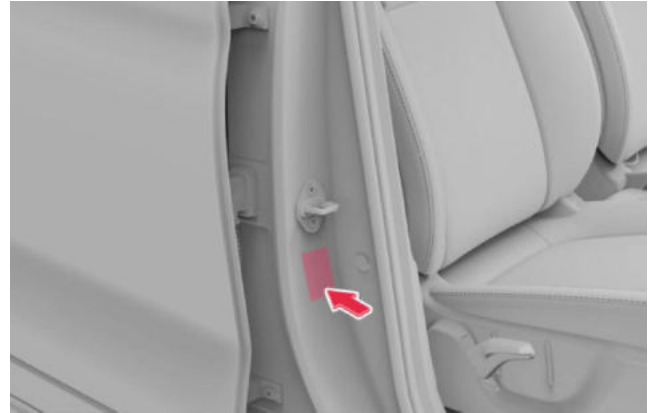

The tire pressure label is above the latch on the exterior panel of B pillar on the right side of the vehicle.

Technical information

MOTOR CONTROLLER NAMEPLATE

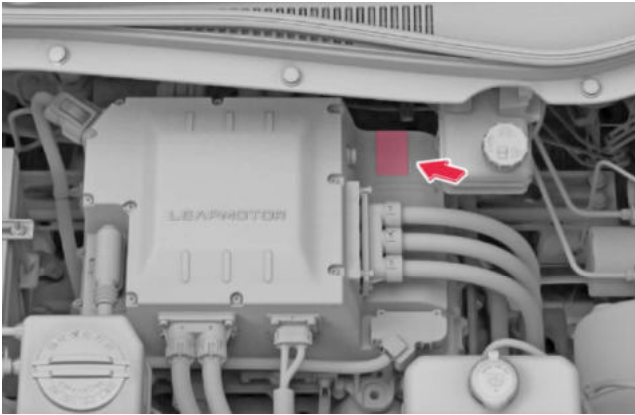

The MCU nameplate is fitted on the controller casing.

DRIVE MOTOR NAMEPLATE

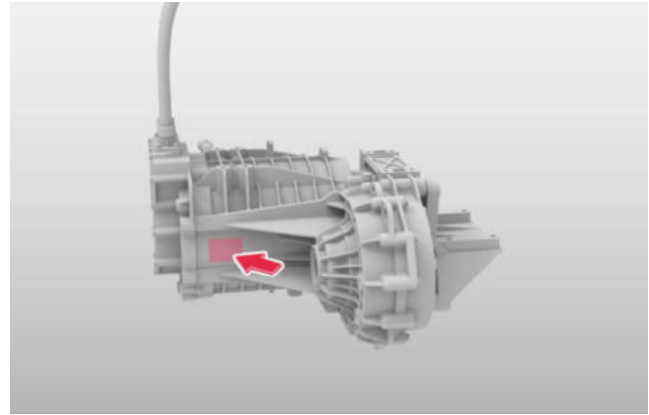

The drive motor nameplate is fitted on the driving motor housing.

DRIVE MOTOR NUMBER

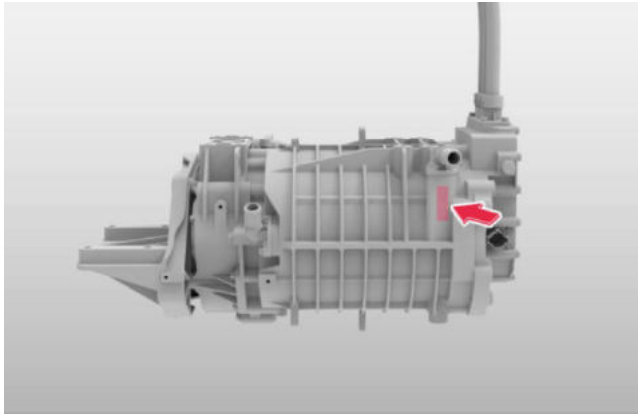

The drive motor number is inscribed on the driving motor housing.

MOTOR CONTROLLER HIGH-VOLTAGE WARNING SIGN

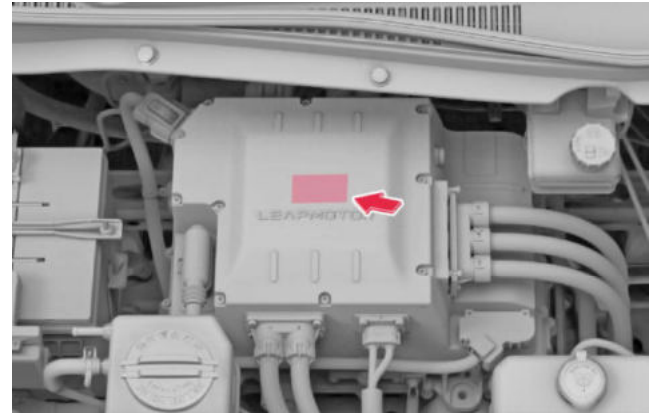

The MCU high-voltage warning sign is fitted on the controller casing.

Technical information

AIRBAG WARNING SIGNS

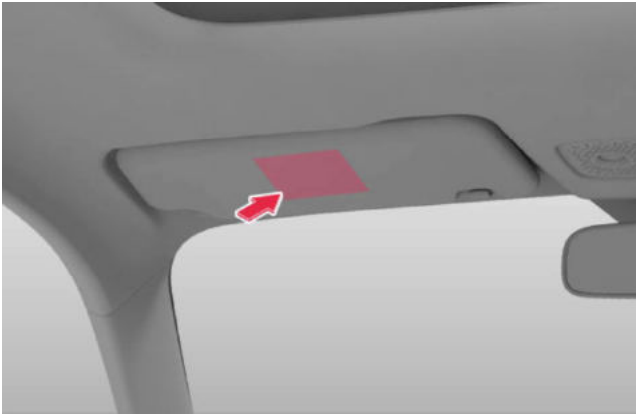

The airbag warning signs are fitted on both sides of the front passenger sun visor.

TRACTION BATTERY PACK HIGH-VOLTAGE WARNING SIGN



The HV warning label of the traction battery is pasted on the outer side of the traction battery pack.

BATTERY PRODUCT INFORMATION NAMEPLATE



The battery product information nameplate is pasted on the outer side of the traction battery pack.

MOTOR COMPRESSOR HIGH-VOLTAGE WARNING SIGN

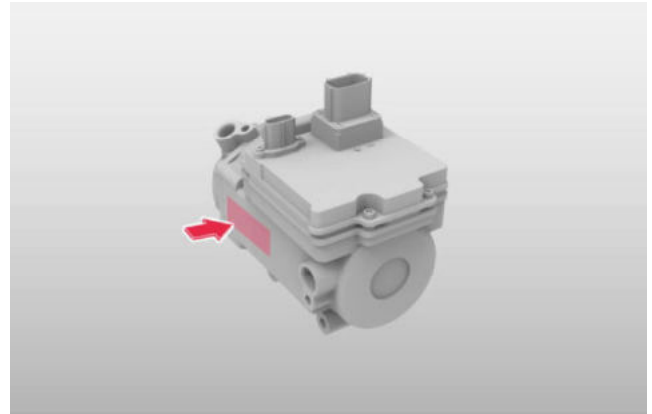

The motor compressor high-voltage warning sign is fitted on the compressor.

Technical information

TECHNICAL PARAMETERS

OVERALL DIMENSIONS OF VEHICLE

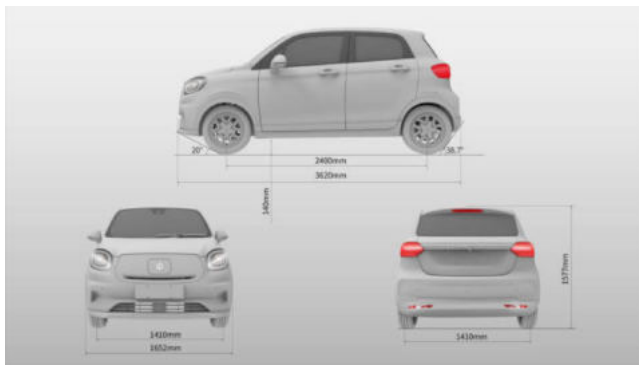

TECHNICAL PARAMETERS OF VEHICLE

Item		Parameter
Product model		T03D
Model of traction battery		LP-PBP23B-AA
Overall dimensions (mm) (excluding exterior rearview mirror)	Length	3620
	Width	1652
	High	1577
Wheel track (mm)	Front	1410
	Rear	1410

Item		Parameter
Wheel base (mm)		2400
Curb weight (kg)		1175
Axle load distribution under curb mass (kg)	Front axle	665
	Rear axle	510
Maximum allowable total mass (kg)		1475
Maximum allowable axle load distribution (kg)	Front axle	790
	Rear axle	740
Minimum ground clearance (mm)		140
Front suspension (mm)		697
Rear suspension (mm)		523
Minimum turning diameter (m)		9.7
Approach angle (°)	No load	20
	Full load	17.9

Item		Parameter
Departure angle (°)	No load	38.7
	Full load	33.7
Maximum speed (km/h)		130
Vehicle dynamic balance requirement (g)		≤ 8
Number of axles/drive shaft		2/ front axle
Driving type		FF
Rated passenger capacity (person)		4
Maximum gradeability (%)		≥30
WLTP driving mileage (km)		265
WLTP energy consumption (kW h/100 km)		16.3

TECHNICAL PARAMETERS OF TRACTION BATTERY

Item		Parameter
Cell	Model	LAE8B5
	Voltage (V)	3.2
	Capacity (Ah)	104

Item	Parameter	
Model of packed energy storage device	LP-PBP23B-AA	
Nominal voltage of energy storage device assembly (V)	358.4	
Nominal capacity of traction battery assembly (Ah)	104	
Total storage capacity of energy storage device (kWh)	37.27	
Total power assembly quality (kg)	295	
Energy density of traction battery system (Wh/kg)	126	
Ingress protection rating	IP67	
Auxiliary power supply voltage (V)	12	
Auxiliary power supply type	Lead-acid	

TECHNICAL PARAMETERS OF MOTOR

Item	Parameter	
Motor model	TZ180XS007	TZ180XS018
Motor rated power (kW)	38	68

Technical information

Item	Parameter	
Rated speed of motor (r/min)	6000	6000
Rated torque of motor (N•m)	60	60
Peak power (kW)	70	70
Peak speed (r/min)	12000	12000
Peak torque (N•m)	158	158

TECHNICAL PARAMETERS OF MOTOR CONTROLLER

Item	Parameter
Model	KTZ36X24S007
Control mode	Torque and speed control
Input voltage (V)	260~450
Peak output capacity (kVA)	104
Cooling type	Water cooling

TECHNICAL PARAMETERS OF OTHER MAIN ASSEMBLIES

Item	Parameter	
Reducer	Type	Mechanical

Item	Parameter	
	Model	FGCFF007
	Gear ratio	Fixed ratio 8.853
Steering gear	Type	Gear rack type
	Model	3402100-TB02
Suspension	Steering type	Electric Power Steering (EPS)
	Front suspension	McPherson independent suspension
	Rear suspension	Torsion beam semi-independent suspension

TECHNICAL PARAMETERS OF BRAKE SYSTEM

Item	Parameter
Front wheel brake type	Disk type
Rear wheel brake type	Disc type
Parking brake type	EPB electronic parking brake
Free travel of brake pedal (mm)	2.4~6

Item		Parameter
Maximum travel of brake pedal (mm)		108
Reasonable range of brake friction pair (mm)	Front brake disc thickness	20
	Rear brake disc thickness	10
	Thickness of front friction lining	8
	Thickness of rear friction lining	8
	Normal operating range of front brake disc	18~20
	Normal operating range of rear brake disc	8~10
	Normal range of	2~8

Item		Parameter
	front friction lining	
	Normal range of rear friction lining	2~8

TECHNICAL PARAMETERS OF WHEELS AND TIRES

Item		Parameter
Tyre specification		165/65 R15
Tyre pressure (kPa)	Half loading (front/rear)	230/230
	Full load (front/rear)	250/250
Four-wheel alignment (no load)	Front wheel toe-in (one side)	$0.08^{\circ} \pm 0.08^{\circ}$
	Camber angle of front wheel	$-0.15^{\circ} \pm 0.75^{\circ}$
	Front wheel kingpin castor	$5.01^{\circ} \pm 0.75^{\circ}$
	Front wheel kingpin inclination angle	12.434°

Technical information

Item		Parameter
	Rear camber	$-0.9^{\circ} \pm 0.33^{\circ}$
	Rear wheel toe-in (one side)	$0.005^{\circ} \pm 0.33^{\circ}$
Front-wheel turning angle (no load)	Inner side	$38.5^{\circ} \pm 3^{\circ}$
	Outer side	$31.5^{\circ} \pm 3^{\circ}$

TYPE AND USAGE OF FLUIDS TO BE ADDED FOR THE VEHICLE

Item	Specification	Dosage	Remarks
Brake fluid	DOT4	600ml \pm 70ml	/
A/C refrigerant	Refer to the air conditioner warning sign	Refer to the air conditioner warning sign	/
Reducer oil	Shell SL2808	0.8~0.85L	/
Coolant	OAT -25°C	3.55L \pm 0.1L	Above -25°C
Wiper washer fluid	-10°C	1.8L	/

BULB PARAMETERS

Function	Type	Specification	Power (W)	Color
High/low beam headlights	Halogen	H7	55	White
Front direction indicator lamp	LED	/	9	Amber
Daytime running lamp	LED	/	8	White
Front position lamp	LED	/	0.6	White
Rear direction indicator lamp	LED	/	0.9	Amber
Rear position lamp	LED	/	2	Red
Brake lamp	LED	/	0.8	Red
Reversing lamp	LED	/	4	White

Function	Type	Specification	Power (W)	Color
High-mounted stop lamp	LED	/	1.2	Red
Rear fog lamp	LED	/	2.3	Red
License plate lamp	Halogen	W5W	5	White
Rear trunk lamp	LED	/	1.6	White

SVHC INFORMATION TRANSMISSION

Communication of information according to Article 33 REACH
Leap Motor T03 (2024)
<p>This product is composed of articles defined under Article 3(3) of the Regulation No. 1907/2006 of the European Parliament and the Council concerning the Registration, Evaluation, Authorisation and Restriction of Chemicals (REACH). Any supplier shall comply with the duty to communicate information on substances in articles in accordance to Article 33. This product, including any article that the product is composed of, does contain substances meeting the criteria in Article 57 and identified in accordance with Article 59(1) in a concentration above 0.1% weight by weight (w/w). We inform that lead (CAS-No. 7439-92-1) is</p>

Communication of information according to Article 33 REACH	
used in almost all products categories, primary as alloying element and also existed in battery. Recycled aluminum and metals may contain lead as impurity.	
Location of article containing the substance in the product (Detailed, including optional equipment)	Name of substance meeting the criteria in Article 57 and identified in accordance with Article 59(1) in a concentration above 0.1% weight by weight (Typical use according to the REACH Annex XV Dossier)
A-pillar front outer cavity sound insulation rubber block	Azodicarbonamide
A-pillar lower outer cavity sound insulation rubber block	Azodicarbonamide
ECALL key	2-Methyl-4'-(methylthio)-2-morpholinopropiophenone
ECALL host	2-Methyl-4'-(methylthio)-2-morpholinopropiophenone
ECALL host	Tetrabromobisphenol A
ECALL host	N-Methylpyrrolidone
ESP	2-(2-[4-(1,1,3,3-Tetramethylbutyl)phenoxy]ethoxy)ethanol

Technical information

Communication of information according to Article 33 REACH	
EVCC conversion module assembly	melamine
HVAC assembly	Tetrabromobisphenol A
T03 Visor Assembly	Azodicarbonamide
T03EV17C auxiliary material	bis(2-ethylhexyl) phthalate
T03EV17C auxiliary material	Azodicarbonamide
T03 Steering Wheel Assembly -TD01	UV Absorber UV-329
T03 Steering Wheel Assembly -TD01	melamine
T03 Steering Wheel Assembly -TD01	Triglycidyl isocyanurate
T03 Ventilation window cover end cover	Azodicarbonamide
Airbag Electronic Control Unit Assembly (8)	2-Methyl-4'-(methylthio)-2-morpholinopropiophenone
Side impact sensor	2-Methyl-4'-(methylthio)-2-morpholinopropiophenone
Window ripple anti-pinch controller assembl	Tetrabromobisphenol A
Window ripple anti-pinch controller assembl	Azodicarbonamide

Communication of information according to Article 33 REACH	
Wheel assembly	1,2-dimethoxyethane
Astern ultrasonic probe	Tetrabromobisphenol A
Astern ultrasonic probe	2-Methyl-4'-(methylthio)-2-morpholinopropiophenone
Reverse video camera assembly	2-Methyl-4'-(methylthio)-2-morpholinopropiophenone
Floor harness assembly	2,2'-Methylenebis(6-tert-butyl-4-methylphenol)
Electric steering column with intermediate shaft assembly	Tetrabromobisphenol A
Electric drive assembly	N-Methylpyrrolidone
Electronic steering column lock	Tetrabromobisphenol A
Power battery pack assembly	Diphenyl(2,4,6-trimethylbenzoyl)phosphine oxide
Copilot seat assembly	2,2'-Methylenebis(6-tert-butyl-4-methylphenol)
High stop lamp	2-Methyl-4'-(methylthio)-2-morpholinopropiophenone
Rear bumper harness assembly	2,2'-Methylenebis(6-tert-butyl-4-methylphenol)

Communication of information according to Article 33 REACH	
Rear door microswitch assembly	Tetrabromobisphenol A
Rear door harness assembly	2,2'-Methylenebis(6-tert-butyl-4-methylphenol)
Rear shock absorber assembly	Ethylene glycol monoethyl ether acetate
Rear wheel cover soundproof rubber block	Azodicarbonamide
Engine room wiring harness assembly	Octamethylcyclotetrasiloxane
Engine room wiring harness assembly	2,2'-Methylenebis(6-tert-butyl-4-methylphenol)
Driver seat assembly	2,2'-Methylenebis(6-tert-butyl-4-methylphenol)
AC charging gun assembly	Tetrabromobisphenol A
AC charging gun assembly	bisphenol A
Controller assembly	Octamethylcyclotetrasiloxane
Controller assembly	2-Methyl-4'-(methylthio)-2-morpholinopropiophenone
Controller assembly	bisphenol A
Controller assembly	Tetrabromobisphenol A

Communication of information according to Article 33 REACH	
Controller assembly	melamine
Blind spot monitoring radar	melamine
Blind spot monitoring radar	Tetrabromobisphenol A
Blind spot monitoring radar	Antimony compounds, with the exception of the tetroxide (Sb2O4), pentoxide (Sb2O5), trisulphide (Sb2S3), pentasulphide (Sb2S5)
Blind spot monitoring radar	Methylhexahydrophthalic anhydride
Front view monocular camera	bisphenol A
Front view monocular camera	Tetrabromobisphenol A
Front view monocular camera	2-Methyl-4'-(methylthio)-2-morpholinopropiophenone
Full frequency speaker assembly	N-Methylpyrrolidone
Four-door glass lift switch	Tetrabromobisphenol A
Exterior mirror assembly - with heating	Tetrabromobisphenol A
Hazard warning light switch	Tetrabromobisphenol A

Technical information

Communication of information according to Article 33 REACH	
Tail door glass assy	Refractories, fibers, aluminosilicate
Tailgate air spring mounting bracket	Tetrabromobisphenol A
Tailgate gas spring assembly	Tetrabromobisphenol A
Tail door brake light tape	Acrylamide Crystals
Driving warning horn assembly	Tetrabromobisphenol A
One-click start switch	Tetrabromobisphenol A
Instrument panel harness assembly	2,2'-Methylenebis(6-tert-butyl-4-methylphenol)
Instrument display	bisphenol A
Instrument display	Triglycidyl isocyanurate
Instrument display	oxide
Instrument display	Azodicarbonamide
Instrument display	2-Methyl-4'-(methylthio)-2-morpholinopropiophenone
Side wall stiffener assembly	Azodicarbonamide
Side wall inner panel assembly	Azodicarbonamide
Rear door lock body	2-Methylimidazole

Communication of information according to Article 33 REACH	
Rear door harness assembly	2,2'-Methylenebis(6-tert-butyl-4-methylphenol)
Rear combination lamp with guard plate (PCBA not included)	Ethylene glycol monoethyl ether acetate
Front slide assembly	Ethylene glycol monoethyl ether acetate
Front combination light (integrated daily running light)	UV Absorber UV-329
Front combination light (integrated daily running light)	2-Methyl-4'-(methylthio)-2-morpholinopropiophenone
Front combination light (integrated daily running light)	2,2'-Methylenebis(6-tert-butyl-4-methylphenol)
Central control display	2-Methyl-4'-(methylthio)-2-morpholinopropiophenone
Central control display	2,3-Dibromo-1-propanol
Central control display	Triglycidyl isocyanurate
Central control display	Dechloran A
Central control display	N-Methylpyrrolidone
Combination switch	Tetrabromobisphenol A

Communication of information according to Article 33 REACH

The information provided in this document related to material and substance content represents our knowledge and belief, which may be based in whole or in part on available information provided by suppliers to us.

RADIO TECHNICAL INFORMATION

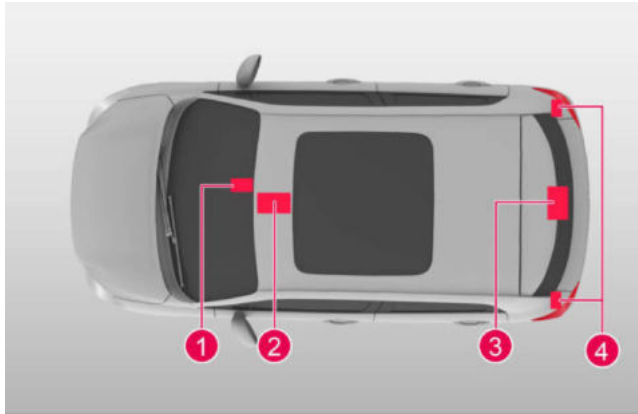

Band (MHz)	Maximum output power (W)(Peak RMS)	Equipment	Position
DAB:170-240	1.1	DAB antenna	1
LTE B1:1920-1980	0.2	Combination antenna	2

Band (MHz)	Maximum output power (W)(Peak RMS)	Equipment	Position
LTE B3:1710-1785	0.2	Combination antenna	2
LTE B5:824-849	0.2	Combination antenna	2
LTE B7:2500-2570	0.2	Combination antenna	2
LTE B8:880-915	0.2	Combination antenna	2
LTE B20:832-862	0.2	Combination antenna	2
LTE B38:2570-2620	0.2	Combination antenna	2
LTE B40:2300-2400	0.2	Combination antenna	2
LTE B41:2555-2655	0.2	Combination antenna	2
GNSS:1560-1605	/(Receiving only)	Combination antenna	2
BT:2400-2483.5	0.01	Combination antenna	2

Technical information

Band (MHz)	Maximum output power (W)(Peak RMS)	Equipment	Position
WIFI:2400-2483.5	0.016	Combination antenna	2
WIFI:5150-5250	0.016	Combination antenna	2
WIFI:5745-5825	0.016	Combination antenna	2
PEPS: 0.125	Passive	PEPS antenna module	2
FM antenna amplifier: 88-108	/(Receiving only)	FM antenna amplifier	3
BSD (point A Hirige): 76000-77000	0.246	Blind Spot Detection (BSD)	4
BSD (Point B Chuhang): 76000-77000	0.316	Blind Spot Detection (BSD)	4
433.92	0.04	Key fob	/
0.125	Passive	Key fob	/

- The radio certification information is pasted on the surface of the part. For details, please check the part label.

NOTE



LEAPMOTOR

<https://www.leapmotor.net>

Copyright by LEAPMOTOR.

The information contained in this publication is effective as of the date indicated below. LEAPMOTOR reserves the right to make changes to the technical specifications, features and design of the vehicles relative to the information in this publication as well as changes to the publication itself.

Edition: Jan 2025, LEAPMOTOR.



Y0T03AO2409en-uk-1

